



**PROTON**  
*e.MAS*

***e.MAS7***  
**OWNER'S MANUAL**

# Foreword

Dear users,

Thank you for your trust in choosing Proton vehicle, which will provide you with excellent safety, comfort, power, and economy. We are looking forward to bringing fun to your work and life with our high-quality products and services.

Please read and comply with the contents of this Manual before using your vehicle for the first time. It will help you to better understand and use your PROTON, ensuring that your new vehicle will be in good technical condition and always perform at its best in the future. The more you know about your vehicle, the more you will enjoy the safety and fun of driving it.

If you find any problems in driving, contact nearby authorised PROTON service outlet, which will provide high-quality service for you in vehicle maintenance and repair. Make sure to maintain your vehicle according to the periodical service maintenance schedule as specified in this manual. This manual provides the all information on all variants in this vehicle model. The configuration mentioned in the manual herein may differ from that of your vehicle. Therefore, the actual configuration of your vehicle shall prevail as far as the configuration is concerned. This manual is a part of the complete vehicle. Please make sure to keep this manual in the vehicle all the time. If you sell this vehicle, please make sure to hand over this manual to the new owner.

Perusahaan Otomobil Nasional Sdn Bhd (PROTON) reserves the right to make changes to the design and specifications and/or to make additions or improvements to the vehicle without any obligation to install the same on vehicles previously manufactured. The driver is required to strictly comply with all laws and regulations governing the use of this vehicle.

This Manual has been written in compliance with such laws and regulations currently in force. PROTON reserves the right to make such amendments and/or revisions to this Manual as and when required. This Manual is a copyright owned by PROTON. This Manual or any part thereof shall not be reproduced, stored in any retrieval system, or transmitted in any form or by any means without the prior written permission of PROTON.

All the data contained in the manual are the latest data at the time this manual is published. In the event of any conflict or discrepancy between the provisions of the English language version of this Manual and Manuals of any other language provided, the provisions of the English language manual shall prevail for the purpose of interpretation and applicability.

Note: The cover and pictures in this Manual are only for reference, which shall be subject to the actual vehicle.

**THIS PAGE IS INTENTIONALLY LEFT BLANK**

---

# Contents

## Notes to Users

- 5 Notes to Users
- 8 Prompt Message
- 9 Event Data Recorder (EDR)\*
- 11 Overview of Exterior
- 12 Overview of Interior
- 13 Overview of Front Compartment

## Safe Travel

- 15 Overview of Seat Belt
- 18 Three-point Seat Belt
- 20 Overview of Airbag
- 21 Positions of Airbags
- 24 Deployment of Airbag
- 26 Selection of Child Restraint System
- 28 Using The Child Restraint System
- 32 Installation of Child Restraint System
- 38 Child Safety Lock

## Enter and Exit

- 39 Car Search Mode
- 39 Intelligent Key
- 41 Vehicle Locking and Unlocking
- 44 Central Locking and Unlocking
- 44 Automatic Locking and Unlocking

- 45 Door Handle
- 45 Driver Easy Access\*
- 46 Opening and Closing the Tailgate
- 50 Anti-theft System
- 51 Front Storage Compartment
- 53 Rear Storage Compartment
- 54 Luggage Compartment
- 55 Roof Rail

## Before Driving

- 57 Adjustment of Driver Seat
  - 58 Seat Memory Function of Driver Seat\*
  - 59 Horn
  - 59 Adjustment of Steering Wheel
  - 60 Steering Wheel Buttons
  - 63 Adjustment of Door Mirror
  - 63 Folding and unfolding of Door Mirrors
  - 65 Adjustment of Interior Rearview Mirror
  - 66 Power Window
  - 69 Panoramic Sunroof\*
  - 72 Wiper Combination Switch
- ## Lighting
- 75 Light Combination Switch

---

78 Automatic High Beam Control (AHBC)

79 Interior Lighting

81 Exterior Lighting

81 Hazard Warning Lamp

## Meter Instrument

83 Overview of Meter Instrument

85 Warnings and Indicators

## Knowing Vehicles

91 Wired Charging

92 Wireless Charging

94 Intelligent Knob

94 Sun Visor and Vanity Mirror

95 Adjustment of Front Passenger Seat

96 Front Seat Ventilation\*

96 Adjustment of Rear Seat

97 Adjustment of Front Seat Headrest

98 Adjustment of Rear Seat Headrest

99 Head up Display (HUD)\*

## Starting and Driving

101 Driving Instructions

103 Vehicle Power Mode

103 Starting Operations

104 Gear Shift Lever

104 Gear Selections

105 Drive Mode

105 Leaving the Vehicle Without Power-off

107 Service Brake

107 Energy Recovery

108 Electric Parking Brake (EPB)

109 Anti-lock Braking System (ABS)

109 Electronic Brake-force Distribution (EBD) System

110 Electronic Stability Control (ESC) System

111 Anti Rolling Program (ARP)

111 Brake Assist (BA)

112 Traction Control System (TCS)

112 Hill-start Assist Control (HAC)

113 Hill Descent Control (HDC)

114 Hazard Warning (HAZ)

114 Warning Sound for Pedestrian

115 Electric Power Steering (EPS)

115 Tyre Pressure Monitoring System (TPMS)

## Driving Assist

119 Introduction to The Intelligent Driving System

121 Adaptive Cruise Control System (ACC)

- 
- 129 Intelligent Cruise Control System (ICC)
  - 138 Active Lane Change Assist (ALCA)\*
  - 142 Lane Keep Assist System (LKA)
  - 145 Collision Mitigation Support Front System (CMSF)
  - 150 Front Cross Traffic Alert (FCTA)\*
  - 152 Evasive Manoeuvre Assist (EMA)\*
  - 154 Traffic Sign Identification (TSI) System
  - 157 Rear Side Radar Assist System (RSRS)

## Parking Assist

- 163 Park Assist System (PAS)
- 165 360 Camera

## Air Conditioner

- 169 Front A/C Control System
- 173 Air Vent
- 174 A/C Settings

## Charging and Discharging

- 175 Charging Precautions
- 175 Charging Operation
- 176 External Power Supply
- 176 Trip Reservation

## Maintenance

- 177 Maintenance
- 177 Replacement of Key Battery
- 178 Front Compartment Hood
- 180 Coolant
- 181 Brake Fluid
- 182 Washer Fluid
- 182 Wiper Blades
- 184 Low-voltage Battery
- 185 Waking up the System
- 186 Power Battery
- 187 Tyre
- 190 Exterior Cleaning
- 191 Interior Cleaning
- 194 Fault of Headlamps
- 194 Replacement of Fuse
- 197 Fuse Box in Front Compartment
- 199 Fuse Box in Instrument Panel at Driver Side

## In case of Emergency

- 203 Unlocking Door during Emergency
- 204 Emergency Unlocking the Charging Gun
- 204 Towing
- 205 Towing Ring
- 206 Overheating of Drive Motor or Motor Controller

---

207 Overheating of Drive Motor or Motor Controller

208 In Case of Fire

209 Getting Vehicle Out of Trap

## Emergency Rescue

211 Exterior Identification Information

212 Powertrain Information

214 Safety Sign Information

215 Emergency Device Information

216 Parking

216 Emergency Unlocking of Tailgate

217 High-voltage Cutoff Method

219 Protective Equipment

221 Jump Starting

224 Cutting the Vehicle Body

228 In Case Submerged in a Flood

228 Rescuing the Vehicle in Case of Fire

230 Evacuating Occupants during Emergency

230 Power Battery Damage and Fluid Leakage

231 Evacuating the Vehicle From Accident Scene

233 Vehicle Storage

## Technical Information

235 Vehicle Identification Number

236 VIN Label

236 Drive Motor Code

237 Dimension

237 Weight

237 Performance

238 Power Battery

238 Drive Motor Specification

238 Tyre Specification

238 Wheel Alignment Specification

239 Recommended Fluid and Capacity

## Notes to Users

### Manual Instructions

- The multimedia manual, an important part of this manual, is used to introduce the entertainment system of the vehicle. See the multimedia manual for detailed operations of the entertainment system.
- All the information in this Manual is the latest information as of the time of publication. The contents of this Manual are based on the product information at the time of publication. In order to meet the requirements of customers and laws and regulations, the vehicle configuration and performance will continue to be optimized and improved. Your vehicle may be different from the description in this Manual.
- The software version of the vehicle and settings may be updated later. Before the upgrade, you will be informed to obtain your consent. The information displayed after the upgrade may be different from the description in the user manual delivered with the purchased vehicle. The actual situation shall prevail in terms of specific information.

### Vehicle Overview

- Please read the instructions in this manual carefully before initial use, otherwise it may cause personal injury and property damage, and may also result in you losing your maintenance or warranty rights.
- Try to keep the power battery fully charged before driving. When the vehicle is driving, the power battery is gradually discharged. When the power battery is at

low power, it must be recharged. Otherwise, the vehicle cannot run.

- This vehicle is equipped with two types of batteries. One is power battery (high voltage) used to supply power to drive motor and propel the vehicle. The other is low-voltage battery used to supply power to low-voltage electrical systems such as headlamps, audio, horns, etc. The power of low-voltage battery comes from power battery.
- This vehicle adopts a charging plug to connect with power grid to charge the power battery. Besides, this vehicle has energy recovery function. During braking, the motor generates electricity and store part of it in power battery so as to extend the driving range of the vehicle.
- This vehicle features the creep function. That is, when the vehicle is in a drivable state (the ready for operation indicator is on) and in forward gear (D) or reverse gear (R), release brake pedal and parking brake and the vehicle will move forward or backward slowly.

### High Voltage Safety

The following information is helpful to keep passengers and emergency personnel safe from high voltage:

- The high voltage fuse (inside the power battery) provides short-circuit protection for the power battery.
- Positive/negative high-voltage cables connected to power battery are usually controlled by high-voltage relay. When disconnecting the vehicle high voltage power supply, the relay is disconnected

to prevent the current from flowing out of power battery.

- The voltage won't be safe enough for human touch until 5 minutes after the power supply disconnection. To prevent serious injury or death caused by accidental contact with high-voltage electricity, it is strictly prohibited to touch, cut off or damage any orange high-voltage cables or high-voltage components.
- High-voltage cables are insulated from the metal body of the vehicle. High-voltage electricity flows through these cables, not through the metal body. As the metal body is insulated from high voltage parts, it is safe to touch the metal vehicle body.

### Warning Information

- When the power system fails or the user operates improperly, the instrument cluster automatically displays warning information. Please read the information and follow its instructions. If the warning indicators turn on, warning information is displayed or the low-voltage battery is faulty, the power system may not start. In this case, try to restart the system. If the ready for operation indicator is not on, please contact authorised PROTON e. MAS service outlet for maintenance.
- When the collision sensor detects a certain level of impact, the system and high voltage current output will be urgently cut off to minimize the risk of electric shock. If the emergency cut-off system is activated, the vehicle will not be able to restart. To restart the vehicle, please

contact an authorised PROTON e. MAS service outlet for maintenance.

- The removal and replacement of any high-voltage components in the vehicle may affect the performance and high-voltage safety, therefore any work involving the removal and replacement of high-voltage components must be the responsibility of authorised PROTON e. MAS service outlet.



The vehicle is equipped with high voltage DC and AC systems as well as 12 V low voltage system. High voltage DC and AC equipment systems are extremely dangerous. Serious injury or death may occur in case of failure. ◀

### Important Notes

- Inspect the tyre wear and tyre pressure regularly as per the methods and tyre pressure requirements recommended in this manual.
- Only use the oil and fluid recommended in this manual and perform maintenance according to the requirements.

### Safety Precautions

- Pay attention to the high-voltage cables in orange yellow insulator in the front compartment. Do not touch the high-voltage components with bare hands without disconnecting high-voltage power. High-voltage components include: drive motor controller, power harness device, on-board charger, high-voltage main cable, fast charging plug, fast charging socket, power battery, drive motor, slow charging socket, slow charging plug, etc.

- Do not touch the positive and negative poles on the power battery body with both hands at any time.
- Do not crush, pierce or burn the power battery and the other similar actions, which will damage the battery system.
- If the vehicle catches fire, leave the vehicle as soon as possible and use a carbon dioxide fire extinguisher to extinguish the fire. If the fire is severe, immediately stay away from the scene and call the fire and rescue authority.
- Do not dismantle, sell, transfer, modify or store power batteries without authorisation. It should be the responsibility of authorised PROTON e.MAS service outlet to recycle and remove the power battery from the vehicle according to the prescribed procedures to prevent safety accidents.
- When cleaning the vehicle, the high-pressure water jet nozzle shall not be aimed at bottom connector of the chassis for flushing.
- The ambient temperature for vehicle parking should be between  $-30^{\circ}\text{C}$  and  $55^{\circ}\text{C}$ . Otherwise, it may cause the vehicle to malfunction.
- The vehicle is equipped with an anti-lock brake system (ABS). Therefore, press the brake pedal firmly rather than make inching braking during emergency braking.
- This vehicle is equipped with airbags. For the safety of children, do not use any rearward facing type of child restraint system on a seat protected by a frontal airbag (when the airbag is activated).
- The vehicle operating environment should be free of corrosive, explosive and insulating gas or conductive dust, and be away from heat sources.
- It is necessary to use and place a floor mat with appropriate sizes properly. The floor mat shall not affect the normal operation of each pedal to avoid affecting the movement of the pedals due to the sliding of the floor mats and causing traffic accidents.

### Accessories, Spare Parts and Modifications

- For your driving safety, do not disassemble or replace any vehicle parts or components on your own.
- Modification or installing other devices to the vehicle is strictly prohibited. PROTON shall not bear any responsibility for any direct or indirect losses incurred from refitting or installing other devices.
- PROTON is only responsible for tested and certified original hardbound accessories and optional devices. PROTON original hardbound accessories are preferred in order to ensure the vehicle performance and safety as much as possible.

## Prompt Message

This Manual provides information on all variants of this model. The descriptions in this Manual may differ from the actual configuration of your vehicle. Your actual vehicle shall prevail.

## Warning



It indicates that serious injury or death may result if this warning is ignored. The steps or requirements stated must be strictly followed. ◀

## High Voltage



This indicates that the event stated here is related to the high voltage circuit of the vehicle and must be strictly observed. Otherwise, it may lead to electric shock, serious injuries or even death. ◀

## Caution



This indicates that the steps and requirements stated in the notice must be strictly observed. Otherwise, your vehicle may be damaged. ◀

## Description



This indicates that the descriptions stated here contains information that will enable you to better use your vehicle. ◀

## Environmental Protection







Issues described are related to environmental protection. ◀

## Asterisk

The asterisk “\*” symbol that appears after a title or name indicates that the configuration or function described is only available on certain models and may not necessarily fit to this vehicle. ◀

## Graphical Information

-  Indicate an object.
-  Indicate the motion direction of an object.
-  Indicate the rotation direction of an object.
-  Indicate that such behavior is prohibited or occurrence should be prevented.

## Event Data Recorder (EDR)\*

PROTON vehicle is equipped with an event data recording system that conforms to the relevant national standards.

This system is used to record the relevant information when a vehicle collides, such as the driving speed (the signal comes from the chassis controller and is obtained from the sensor, indicating the speed at the time of the event) and braking status (indicating whether the vehicle is braking at the time of the event).

When a collision occurs, the current event data can overwrite the previous non-locked event data according to the time sequence of the accident data storage.

EDR helps relevant personnel understand the state of the vehicle at the time of the event, and facilitate relevant parties to act in accordance with relevant laws and regulations. In addition, the information can be used for engineering research and help PROTON automobile continuously improve product quality and safety.

According to requirements of national laws and regulations, it may need to disclose relevant recorded data to certain authorities (such as public security organisations or other institutions that have access to the event data recording system).

Special data reading equipment conforming to corresponding standards shall be used to read data. The special equipment is connected to the OBD interface of the vehicle or the EDR controller is separately connected to extract the data. Only authorized individuals or organizations can read data.

Access to data reading equipment: If necessary, you can contact an authorized PROTON e.MAS service outlet and apply to the manufacturer for access to the equipment with their assistance.

## Overview of Exterior

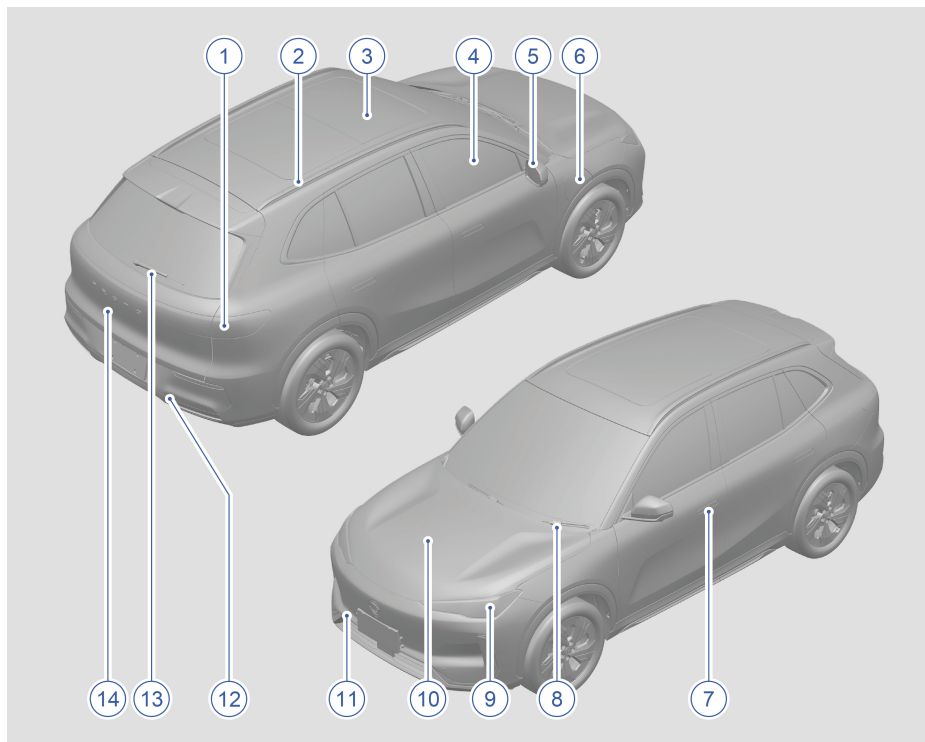

- |   |                                   |
|---|-----------------------------------|
| 1. Rear combination lamp                  | 8. Front wipers                   |
| 2. Roof rack                              | 9. Front combination lamps        |
| 3. Panoramic sunroof*                     | 10. Front compartment hood        |
| 4. Window                                 | 11. Front towing hook cover plate |
| 5. Door mirror (Exterior rearview mirror) | 12. Rear towing hook cover plate  |
| 6. Charging port                          | 13. Rear wiper                    |
| 7. Exterior door handle                   | 14. Tailgate                      |

## Overview of Interior

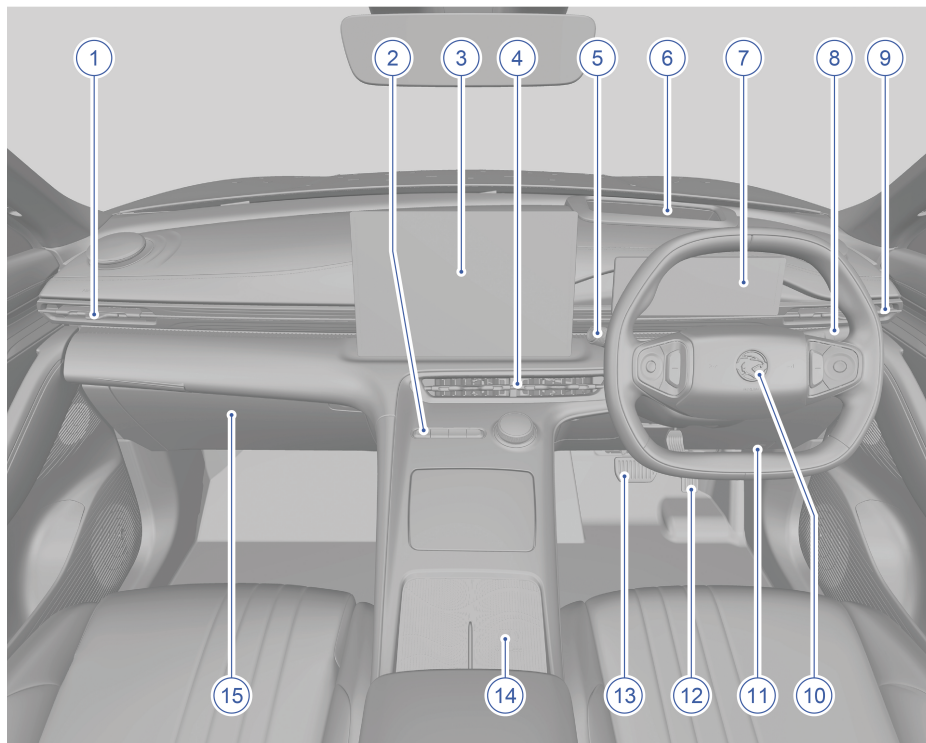

- |   |  |
|---|--|
| 1. Left air vent                            | 9. Right air vent                        |
| 2. Control switches on centre console       | 10. Steering wheel                       |
| 3. Multimedia screen                        | 11. Front compartment hood opening lever |
| 4. Centre air vent                          | 12. Accelerator pedal                    |
| 5. Light and Wiper combination switch lever | 13. Brake pedal                          |
| 6. Head up display (HUD)*                   | 14. Wireless charging area               |
| 7. Meter instrument display screen          | 15. Glove box                            |
| 8. Gear shift lever                         |  |

## Overview of Front Compartment

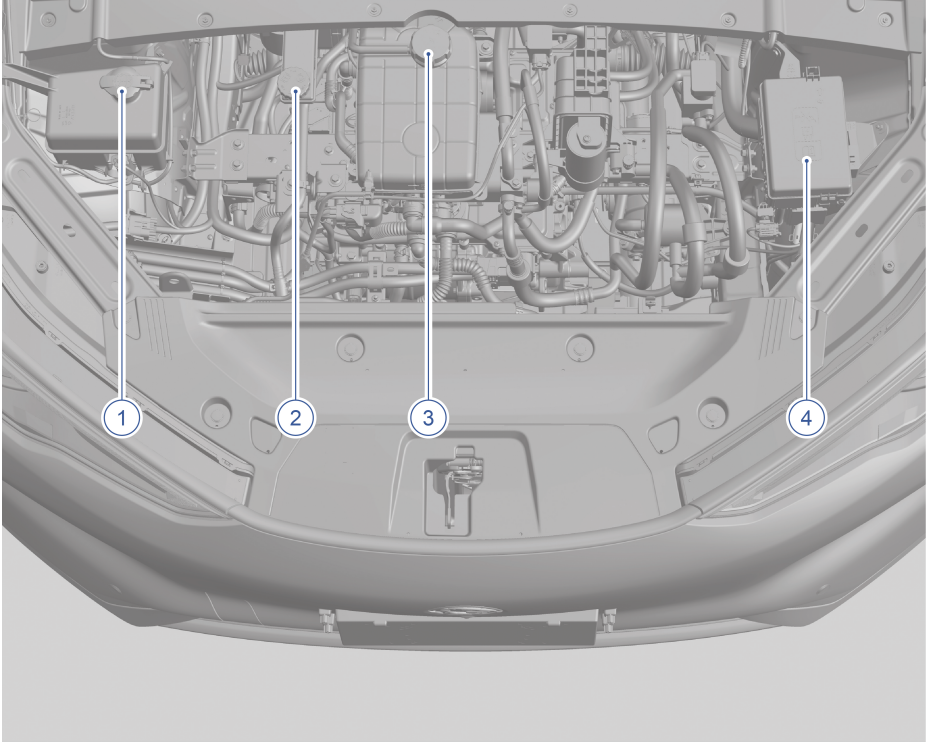

- 1. Washer fluid reservoir
- 2. Braking fluid reservoir
- 3. Coolant expansion tank
- 4. Front compartment fuse box

**THIS PAGE IS INTENTIONALLY LEFT BLANK**

## Overview of Seat Belt

This section describes how to use the seat belt properly. This includes what you should and should not do when operating the seat belts.

 Do not sit on the seat with unusable seat belt. The severity of injury will be much higher in case of traffic collision for passenger not properly restrained with the seat belt. Passengers not restrained with seat belt is at greater risk of injury in an accident due to uncontrolled contact with vehicle interior or be thrown out of vehicle. Make sure all passengers have fastened the seat belts properly before starting your journey.



 Passengers are prohibited to sit in the luggage area. In a collision, passengers sitting in the luggage area are not restrained and thus is at risk of severe injuries or death. All passengers are required to be seated and restrained with the seat belt. Children and infants should be restrained with a suitable child restraint system.

This vehicle is fitted with the seat belt warning light to remind of unfastened seat belts. Make sure to fasten seat belt properly when driving.

Accidents are unpredictable. Statistics showed properly restrained passenger has a lower risk of severe or fatal injury in an accident.



## How Seat Belts Saves Lives

When you sit in the vehicle, you are travelling at the speed of the vehicle.

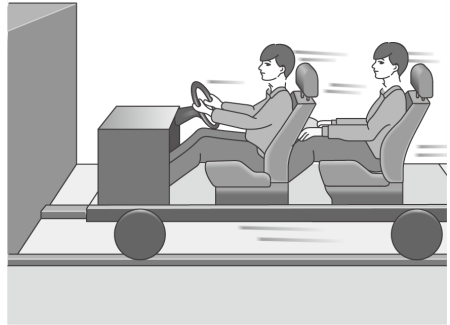

An accident will cause a sudden deceleration of the vehicle. An unrestrained passenger will continue to move forward until obstructed by the interior components of the vehicle (i. e. steering wheel, instrument panel, windscreen, etc.). This increases the risk of severe or even fatal injuries.



With the seat belt fastened, passengers will be restrained to the vehicle and will have a controlled deceleration. Thus the risk of injury is greatly reduced.

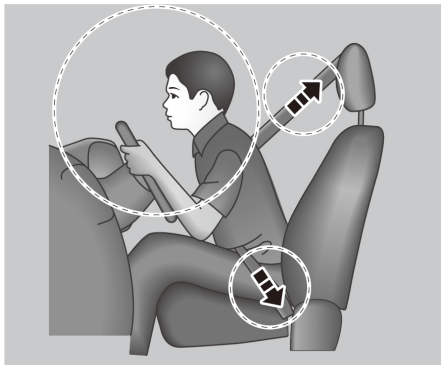

### Correct Sitting Posture

Correct sitting posture is important for seat belt and airbag to offer a maximum protection during crash. The shoulder anchor height can be adjusted to several levels. If the shoulder belt contact with your neck, adjust the shoulder anchor and/or your seat cushion height until the seat belt is positioned properly on your shoulder. Correct sitting posture can ensure:

- Vehicle can be operated and controlled accurately, effectively and safely.
- Allow driver to be supported effectively to avoid driving fatigue.
- To allow the maximum protective function of the seat belt and airbag.

 Make sure that the body is not too close forward with steering wheel in order to get enough distance for the airbag deployment. ◀

When the vehicle is running, avoid over leaning position for the seatback. The shoulder belt may not be effective in restraining the passenger, causing passengers to slide under the seat belt in the case

of a frontal collision thus at risk of a serious injury. ◀



 Do not stretch head or arm out of the window when vehicle is running. This exposes the passengers to the being injured from external sources, and will reduce the protection effectiveness of the airbags in a collision. ◀



 When the vehicle is running, all passengers should wear seat belts properly. In case of emergency braking or an accident, wearing seat belts properly can reduce the injury of passengers.

- Improper wearing or not wearing seat belts may cause serious casualties!

- No occupant shall sit in the area without seat or seat belt or on a seat with damaged seat belt.
- Each seat belt can only be used by one person. Do not share a seat belt with more than one person (including children).
- Do not hang the shoulder belt on the neck or pass through the armpit.
- Do not remove, disassemble or modify the seat belt.
- The seat belt in the vehicle is mainly designed according to the body shape of adults, and children should wear appropriate child safety devices.
- Do not clean the seat belt with bleach, dyes or chemical solvents. ◀
- Adjust the headrest : Adjust according to the body height to make position of headrest consistent with that of head.
- Wear the seat belt properly.

### Correct Sitting Posture for Front Passenger

For safety concern and to avoid injuries, front passenger should adjust the sitting posture in the following way:

- The distance between front passenger and instrument panel shall not be less than 25 cm.
- Seatback should be adjusted to a comfortable upright position and support your back.
- The headrest should be adjusted to be at the same level with your head.
- Wear the seat belt properly.

### Correct Sitting Posture for Driver

Correct driver sitting posture is of great importance for safe driving. For your own safety and to reduce the risk of injury, it is recommended for the driver to adjust in the following ways:

- Adjust the backrest: The seatback shall be adjusted to a comfortable upright position and support your back.
- Adjust the seat height: Make sure your own comfort and good front vision (about a fist distance between your head top and the headlining).
- Adjust the fore-aft position of the seat: Adjust so that the leg still can be kept bent when the brake pedal is applied.
- Adjust the steering wheel: The distance between the steering wheel and chest shall not be less than 25 cm, and the steering wheel can be rotated 180° with one hand and the hand can be kept bent.

### Wearing the Seat Belt Properly

The descriptions in this topic apply to adult occupants.

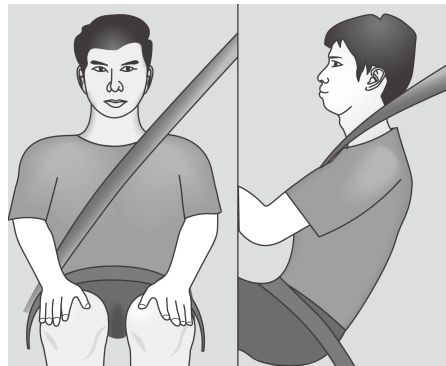

Always sit up straight and put your feet on the floor. Try to fasten the hip belt as low as possible and make it cling to the hip and make it just touch the thigh. The hip belt will apply restrictive force to the hip bone and

will prevent hip belt sliding down in case of a traffic collision.

The hip belt will apply force to abdomen if the passenger slides below the hip belt. This may result in severe and even fatal injuries. Shoulder belt should be fastened across shoulder and chest. Such positions of body are most capable of bearing restriction force of seat belt. The shoulder belt will lock in case of an emergency braking or a traffic collision.

### Wearing Seat Belt for Pregnant Woman

Before a pregnant woman drives a vehicle, consult a doctor to see if she can drive the vehicle.

The method for pregnant women to wear seat belts is basically the same as that for normal use, but the following matters should be noted:

During pregnancy period, the best practice is always fasten the seat belt and keep the lap belt as low as possible across the hips. Wear the shoulder belt across the chest avoiding the abdomen.

When driving, sit upright and adjust the seat as far as possible. This will reduce the risk of injuries to woman and unborn child during airbag deployment.

 If a pregnant woman uses a seat belt incorrectly, the seat belt may cause serious injury or death to the mother and the unborn child during emergency braking or in a crash. ◀

## Three-point Seat Belt

1. Pick up the latch plate, and pull seat belt across body. Do not twist the seat belt ◻  
The three-point seat belt may lock when being pulled across body too fast. If this occurs, release and retract it a little to unlock it. And then pull the seat belt slowly across your body.

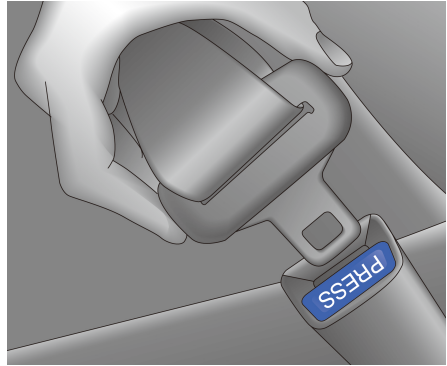

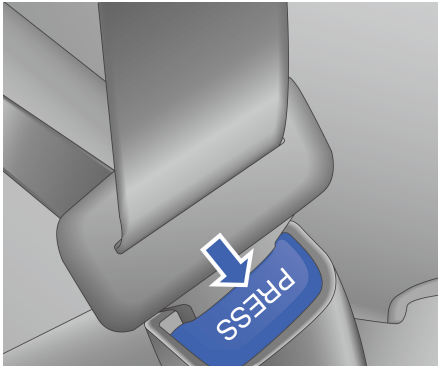

2. Press the latch plate into the buckle until a “click” sound is heard ◻  
Pull the latch plate to make sure it is locked. Make sure the position of the release button on the buckle for the convenience of unfastening the seat belt when necessary.
3. The lap belt can be tightened if the shoulder belt is pulled up.



4. To release seat belt, press red button on the buckle. Seat belt should return to unused state.

 Avoid any foreign objects such as food scraps, nut shells, buttons, coins, viscous liquid from falling into the seat belt buckle. It may cause the failure of the seat belt reminder function and the locking or unlocking function of the buckle. ◀

 Do not insert objects other than the vehicle latch plate into the buckle. Otherwise, it may cause the failure of the buckle. This will reduce the protective effect of the seat belt and may cause serious personal injury or death. ◀

 In order to prevent the seat belt from hurting the surrounding area due to too fast retraction or getting stuck due to too slow retraction, please return the seat belt to the original position after unfastening the seat belt. ◀

 The door will not clip the seat belt until it is closed. Otherwise, the seat belts and doors will damage. ◀

## Seat Belt Pretensioner

Seat belt pretensioner is available for front seat belt. In the event of a vehicle collision

and the seat belt device reaches the trigger condition, the seat belt will be tensioned to keep the passengers safe. The pretensioner can only work once. After a collision, it is necessary to contact an authorised PROTON e.MAS service outlet for a new pretensioner, and other seat belt system components may need to be replaced.

## Seat Belt Unfastened Reminder

This vehicle is equipped with an unfastened seat belt reminder function for the driver and front and rear passengers. When the seat belt unfastened alarm is triggered, the seat belt unfastened warning lamp  on the combination instrument display will illuminate in different states, and the combination instrument display will show the seat with the seat belt unfastened.

When the power system is activated, the warning lamp illuminates if the driver, front or rear passenger seat belt is not fastened. When the vehicle speed is between 10 ~ 25 km/h or the driving distance forward is more than about 300 metres, this lamp will flash slowly with a warning tone; when the vehicle speed is more than 25 km/h, this lamp will flash quickly with a warning tone; when the vehicle speed is more than 10 km/h, the lamp will flash with a warning tone if the seat belt is unfastened. And the lamp will turn off and the warning tone will disappear until the seat belt is fastened in the corresponding position.



- Fastening seat belt properly can lower the risk of being hurt at emergency braking and traffic accidents. Thus, the driver

and passengers should all fasten seat belts properly during driving.

- Please pay attention to the illuminated warning lamp on the combination instrument display; otherwise, serious personal injury and property damage will be caused. ◀

## Overview of Airbag



- Airbag is an integral part of the passive safety system, which can never replace seat belts. All the occupants in vehicle shall fasten seat belts during driving.
- Under the influence of the collision position, angle, degree and property of objects collided, airbags may not be deployed in all accidents. The airbag can cause great impact when it is employed, so the driver and front occupants should adjust their seats to have a sufficient safety distance from the frontal airbags, wear seat belts correctly and maintain correct sitting posture to avoid serious personal injury or death.
- It is necessary to ensure that there is no obstacle in the way of airbag deployment. It is forbidden to place any object between the occupant and the airbag. If any obstacle exists between occupants and airbags, the airbags may not be inflated normally, or the obstacle may be squeezed into human body during deployment, resulting in severe casualties.
- After the airbag is unfolded, do not touch it to avoid scalding.
- When the airbag is deployed, some gas and dust will be released, which may irritate the skin and eyes. Please goto hospital for treatment if you feel uncomfortable.
- Do not maintain, repair, remove or replace any part of airbag system by yourself. Otherwise, the system may not work normally, causing serious casualties.

- The airbag system can only serve protection once. If the airbag has been deployed, it must be replaced at an authorised PROTON e.MAS service outlet immediately. ◀

 Due to the considerable speed and force when the airbag is unfolded, do not let infants and children or hold them on the front seat with airbag to avoid serious casualties. ◀

## Positions of Airbags

### Front Airbag

In case of front impact, front airbags can effectively protect occupants from being injured head-on.

When the vehicle suffers from moderate to severe front impact or nearly front impact which reaches the triggering condition of the system, the airbag will be inflated with gas so as to buffer the forward charging speed of driver and front passenger, and prevent the driver and front passenger from hitting on the steering wheel and dashboard directly.

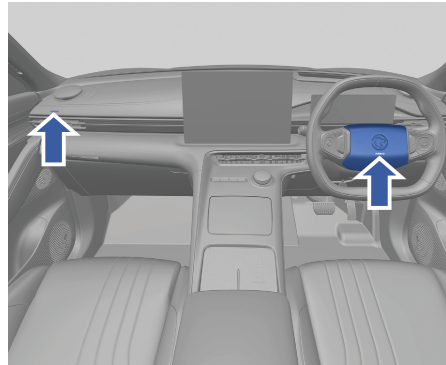

The driver airbag is mounted in the center of steering wheel and the front passenger airbag in the instrument panel above the glove box, respectively, marked with “AIRBAG”.

 The inflation and deflation of airbags complete in a very short time and only deploy once. These deployed airbags will no longer provide protection to the occupants from any subsequent impact. ◀



- Do not press or hit the driver airbag cover plate with force. Otherwise, the driver airbag may accidentally deploy and cause personal injury.
- Do not put things or pets in front of the instrument panel or glove box as well as on the steering wheel with airbags installed. They may hinder the deployment of airbag or cause severe injury or death of occupants due to its strong deployment force. Do not modify, remove, knock or open any front airbag components or line; otherwise, the airbag may suddenly inflate or the system will become inoperable, resulting in personal injury or death.



 During the operation of the vehicle, do not sit on the side of the seat or lean against the instrument panel. Any person stands against or stays very close to the airbag may be seriously injured or killed when the airbag inflates. Driver and passengers must keep a distance of at least 25 cm from the position of airbag. ◀

 Contact an authorised PROTON e. MAS service outlet immediately in the following cases:

- The front airbags have been deployed.
- The front part of the vehicle was impacted but the front airbags are not triggered to deploy.
- The front airbag cover has cracks, scratches or other forms of damage. ◀

### Side Airbag

Side airbag provides further protection for the driver and front passenger, based on the safety protection provided by seat belts. In case of a moderate or severe side impact,

the side airbag can reduce personal injury by inflating and working together with the seat belts simultaneously.

Side airbags can mainly reduce chest injuries for driver or front passenger.

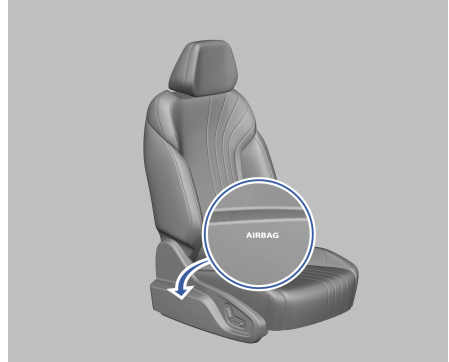

Side airbags are mounted in the seatbacks of the driver seat and front passenger seat; The seats are marked with "AIRBAG".

 Due to the considerable speed and force when the side airbag is inflated, do not put your head and hands out of the window or being close to the deployment area of the side airbag when the vehicle is in motion. Otherwise, serious casualties may occur to the occupants. ◀

 Do not install a seat cover on any seat equipped with side airbag. Otherwise, it may affect the deployment of side airbag.



 Contact an authorised PROTON e. MAS service outlet immediately in the following cases:

- Side airbags have been deployed.
- The door is impacted, though the side airbag is not triggered to deploy.

- The cover of seats at the side airbag assembly has cracks, scratches or other forms of damage. ◀

 Before consult an authorised PROTON e.MAS service outlet, do not perform the following operations to avoid affecting the normal operation of side airbag:

- Installing electronic devices such as mobile two-way radio communication devices.
- Refit the passenger side body structure. ◀

### Side Curtain Airbag

Side curtain airbag provides further protection for the driver, front passenger and rear outboard passenger, based on the safety protection provided by seat belts. In case of a moderate or severe side impact, the side curtain airbag can reduce personal injury by inflating and working together with the seat belts simultaneously. Side curtain airbag can mainly reduce head injuries for driver, front passenger and rear outboard passenger.



Side curtain airbags are mounted on the roof side member on the left and right sides of

the vehicle; These side curtain airbags are marked with "AIRBAG".



As the side curtain airbag has considerable speed and force when it is unfolded, it is prohibited to put your head and hands outside the window or close to the area where the side air curtain is deployed when the vehicle is driving, otherwise serious casualties may occur. ◀



Do not install any decorative parts around the side curtain airbag, such as windshield, door glass, side pillar, roof side, or stick microphone or any other equipment inside the roof and on auxiliary handles. When the side curtain airbag is deployed, these items will be thrown out under the strong deployment force of side curtain airbag, resulting in personal injuries or malfunction of side curtain airbag. ◀



Contact an authorised PROTON e.MAS service outlet immediately in the following cases:

- Side curtain airbags have been deployed.
- The door is impacted, though the side curtain airbag is not triggered to deploy.
- When the front pillar, rear pillar, roof side member fittings or ceiling fitted with side curtain airbags have cracks, scratches or other forms of damages. ◀



Before consult an authorised PROTON e.MAS service outlet, do not perform the following operations to avoid affecting the normal operation of side curtain airbag:

- Installing electronic devices such as mobile two-way radio communication devices.

- Refitting the suspension system.
- Repair at or near the bracket. ◀

## Deployment of Airbag

### Deployment of Front Airbags

When the vehicle impacts with solid wall at a speed of 25 km/h or above, the airbag will be triggered to deploy.

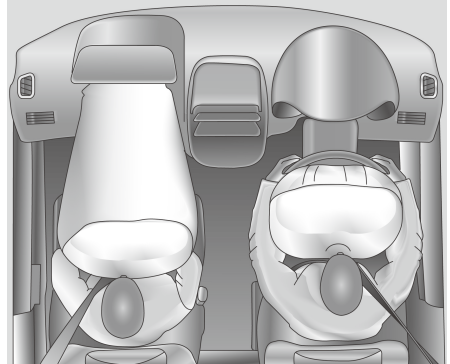

In the event of a collision, the deployment of airbag depends on the collision's object, the collision's direction and the deceleration speed of vehicle caused by the collision. The front airbag will be deployed in the event of front collision and when the airbag device meets its trigger condition.

### Deployment of Side Airbags and Side Curtain Airbags

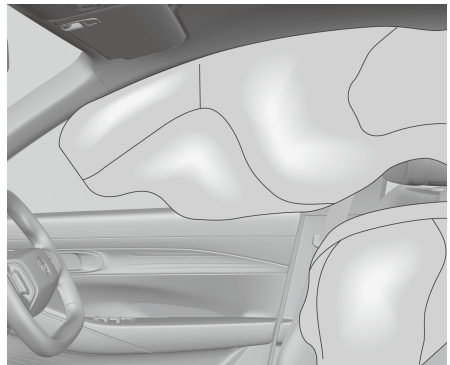

When the vehicle has a moderate or severe side impact and meets the set trigger value, the side airbag and side curtain airbag will be triggered to deploy.

In case of side impact, the deployment of side airbag and side curtain airbag can reduce the risk of upper body and pelvis injury.

### Cases in which Front Airbags May Not Deploy

- The vehicle is not started.
- Collision with deformable objects such as trees.
- When the vehicle collides against low objects such as steps or road dividers.
- When the vehicle falls into a trench or pit suddenly.
- In case of crash (under run crash) against the rear of truck.
- Rollover.
- Side impact, rear impact or slight front impact.
- The airbag system has a failure.
- Other special cases.

### Cases in which the Side Airbag and Side Curtain Airbag May Not Deploy

- Nearly front impact.
- Rear impact.
- Rollover.
- Minor side impact.
- The airbag system has a failure.
- Other special cases.

## Selection of Child Restraint System

This vehicle is capable of supporting the following CRS:

Seat Position Number	1	2	3	4	5
Seating position suitable for universal belted (Yes/No)	No	No	Yes	No	Yes
Seating position suitable for i-Size seat (Yes/No)	No	No	Yes	No	Yes
Seating position suitable for ISOFIX lateral fixture (L1/L2)	No	No	No	No	No
Seating position suitable for ISOFIX rearward facing fixture (R1/R2/R3)	No	No	R1, R2, R3	No	R1, R2, R3
Seating position suitable for ISOFIX forward facing fixture (F2/F2X/F3)	No	No	F2, F2X, F3	No	F2, F2X, F3

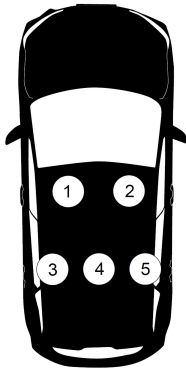

### ISOFIX CRS Size Classes and Fixtures:

- A – ISO/F3: Full-height forward facing toddler CRS;
- B – ISO/F2: Reduced-height forward facing toddler CRS;
- B1-ISO/F2x: Reduced-height forward facing toddler CRS;
- C – ISO/R3: Full-size backward facing toddler CRS;
- D – ISO/R2: Reduced-size backward facing toddler CRS;
- E – ISO/R1: Rearward facing infant CRS;
- F – ISO/L1: Left lateral facing position CRS (carry-cot);
- G – ISO/L2: Right lateral facing position CRS (carry-cot).



For the installation of child restraint system, if necessary, remove the head restraint and install the child restraint system in accordance with the manual's instruction (only applicable to seatback with removable headrest). ◀

Recommended CRS information:

Mass group	CRS yang Disarankan
Group 0: less than 10 kg	Joie i-spin 360 (Rear facing, recliner set to position 1)
Group 0+: less than 13 kg	Joie i-spin 360 (Rear facing, recliner set to position 1)
Group I: 9 ~ 18 kg	Joie i-spin 360 (Rear facing, recliner set to position 1)
Group II: 15 ~ 25 kg	—
Group III: 22 ~ 36 kg	—

 When full-sized rearward facing toddler CRS is installed on a rear seat, the front seat's seatback angle should be adjusted with upright angle corresponding to a torso angle of 15 degrees, then the CRS can be installed correctly without interference with front seat. ◀

 To place and secure child in the child restraint system, please refer in the CRS's owners manual for the details of positioning the integrated harness and integrated headrest of the CRS. ◀

## Using The Child Restraint System

### Rear-facing Child Restraint System

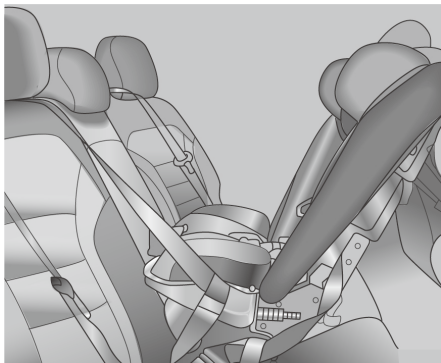

Rear-facing Child Restraint System provides protection by supporting and cushioning the child or infant's back. In case of a traffic collision, the child restraint system will protect infants by keeping them stay in a proper sitting position in the child safety seat.

### Forward-facing Child Restraint System

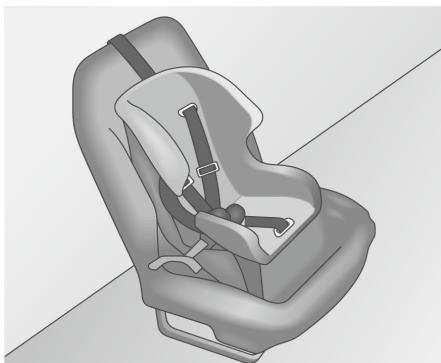

Forward-facing Child Restraint System provides protection by restraining child's body with a suitable seat belt or harness in the

child safety seat. In case of a traffic collision, the child restraint system will protect infants by keeping them stay in a proper sitting position in the child safety seat.

### Booster Seat

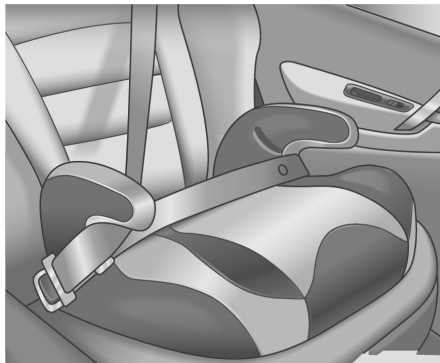

Booster seat is a type of child restraint system that is designed to adjust the seating position of the older children to match the vehicle's lap and shoulder belt of the seat belt. In case of a traffic collision, the vehicle's lap and shoulder belt will primarily restrain the older children.

 Precautions for child restraint system: PROTON strongly recommends children to be restrained with child restraint system when travelling with this vehicle for their protection. The aftermarket child restraint system is removable and can be bought by the owner. Only use proper child restraint system that match your child age or body size. If there is no child restraint system available for your child due to their age or size, the child shall be seated in the rear seat and fasten seat belt for safety purpose. Please refer to Section "Seat Belts" in this chapter for details.

The seat belt or child restraint system (child safety seat) shall be used properly according to the child's age and size. Holding the child in your arms or putting them on your laps cannot replace the child restraint system in terms of safety. In case of traffic collision or emergency braking, the children may impact the windscreen or be squeezed by other passengers.

PROTON strongly recommends the use of child restraint system appropriate to the children body size, and installed in the rear seat. According to the statistics of accidents, it is safer for children to be seated in the rear seats in their child restraint system, or for larger children to be seated in the rear seats and fastening seat belts correctly.

Never install the rear-facing child restraint system in the front passenger seat. Otherwise, in case of an accident, the rapid deployment of the airbag may cause serious injuries or even death to the child.

Unless absolutely necessary, the forward-facing child restraint system cannot be installed in the front seat. Due to the high force generated by the fast deployment of the front passenger airbag, the front passenger seat shall be moved backward as much as possible. Otherwise, airbag will cause serious injuries or even death to the child.

On vehicles equipped with side airbags and side curtain airbags, do not let the child leaning on or being around the door even if a child is sitting in a child restraint system. When the side airbag or side curtain airbag deploy, its quick strong force will cause serious injuries or death to the child.

Make sure to install devices correctly according to all installation instructions

provided by the child restraint system manufacturer. If the installation is not fixed securely and emergency braking or accidents occur, this may also cause serious injuries or death to the child. ◀

## Infants and Younger Children

Everyone in the vehicle should be protected! This includes infants and younger children. Every passenger must use safety protection device.





In any circumstances, do not leave children in the vehicle unattended to avoid them from playing with the switches and seat belt. If the shoulder belt get twisted around the neck of a child, the child may get strangled and severely injured. The airbag and lap/shoulder belt can provide protection to adults and older children but not for infants and younger children.

The seat belt system and the airbag system of vehicle are not designed for protecting infants or younger children. Infants or younger children shall be protected with a proper child restraint systems every time they travel in vehicles. Child who is not restrained properly may run into other passengers or be thrown out of vehicle in case of collision. ◀

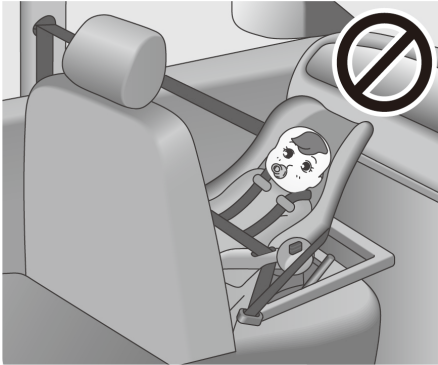

 Do not carry an infant or a child in your arms or on your laps when traveling in this vehicle. Infants or children will become too heavy to carry due to the impact force in case a collision occurs. For example, a 5.5 kg infant could result a sudden 110 kg acting force on the arms of the holder in case of a collision when the vehicle moves at a speed of 40 km/h. Infants should be restrained in a proper child restraint system. ◀



 This vehicle is equipped with a front passenger airbag. Do not use a rear-facing child restraint system on the front passenger seat. ◀

 In case of collision, if the front passenger airbag inflates and contacts the rear-facing child restraint system, the child will be severely injured or killed. A rear-facing child restraint system should be installed in the rear seat. A forward-facing child restraint system should also be installed in a rear seat if possible. ◀

 Infants should be supported comprehensively to lower the risk of getting hurt in the neck and head. In case of collision, infant who is restrained in a rear-facing

child restraint system will sit in it steadily and the collision impact will be distributed to most stout positions of the infant, i. e., its back and shoulder. Infants should always be restrained in a rear-facing child restraint system.

Hip bone of infants is too small. It may be difficult to adjust the vehicle's seat belt as low as possible to the lower part of child's hip bone (on lap). The seat belt may easily move upward and fasten the abdomen of the infants. In case of collision, the seat belt will apply load on the abdomen and will result in a severe or fatal injury. To lower risk of severe or fatal injuries to infants, the infants shall always be restrained in a proper child restraint system. ◀

### Older Children

Older children who cannot be restrained in a proper child restraint system should sit in the rear seat and wear the seat belt.

The manufacturer instructions attached to the child restraint system have the detail descriptions on the body weight and height limits for a child sitting in this child restraint system.



Before a child passes the following applicability test, you should use the child restraint system together with lap belt/shoulder belt:

- Try to sit in the seat as back as possible. Can the child's knee bend on the edge of seat? If yes, please go ahead. If not, please use child restraint system.
- Fasten three-point seat belt properly. Can the shoulder belt be put on child's shoulder? If yes, please go ahead. If not, please use child restraint system.
- Should lap belt be fastened as low as possible and cling to child's hip or just touch the lap (thigh)? If yes, please go ahead. If not, please use child restraint system.
- Can the seat belt be always fastened properly during entire process? If yes, please go ahead. If not, please use child restraint system.

**Question:** How to wear seat belt properly?

**Answer:** Older children should wear lap and shoulder belt (the three-point adult seat belt). The shoulder belt should not contact around the face or neck of the child. The lap belt should cling to their hip and just touch upper part of their thigh; In case of traffic accident, the tighten force of seat belt will only impact on the child's pelvis. Do not fasten the lap belt on the child's abdomen to avoid severe or fatal internal injury to the child in case of collision.

According to accident statistical data, it is safer for children and infants to sit in the child restraint systems in the rear seats. In case of a traffic collision, a child who do not fasten the seat belt properly may run into other passengers who have fastened their

seat belts or may be thrown out of the vehicle. Older children should wear the seat belt properly.



 Do not fasten the seat belt for older children as shown in previous figure. Never allow two children to share a single seat belt. In case of collision, the seat belt will fail to restrain both children and they will run into each other resulting in severe injury. One seat belt is meant only for an adult or an older child. ◀



 Do not fasten the seat belt for older children as shown in previous figure. Do not position the shoulder belt to the back of an older child when the seat belt is fastened. In case of collision, the child may

move forward excessively resulting in possibility of hurting the child's head and neck. The child may slide under the lap belt. The tightening force of seat belt will impact on the child's abdomen resulting in severe and even fatal injuries. Shoulder belt should be fastened properly across the older children's shoulder and chest. ◀

### Description of the Child Restraint System

Generally, It is recommended to restrain infants and young children aged 3 to 4 years old in the rear-facing child restraint system. For children who have large body size to fit in a rear-facing child restraint system, use a front-facing child restraint system. For children whose have large body size to fit in the front-facing child restraint system, they can be restrained in a booster seat and fasten the seat belt.

## Installation of Child Restraint System

It will be safer if children and infants are properly sitted in a child restraint system on the rear seats.

 Before installing a child restraint system on the rear seat, carefully read the instructions attached to the child restraint system and make sure it is suitable to be installed to this vehicle. ◀

### CRS Warning Label

#### Type 1



## Type 2

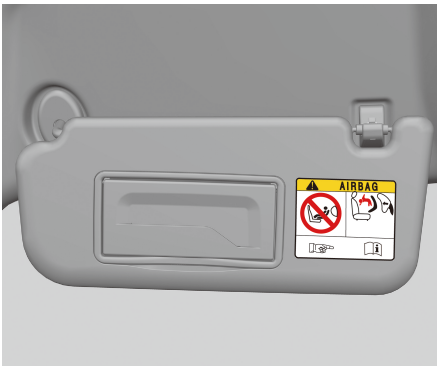

There are warning labels on the front and back of the sunvisor at the front passenger side; To warn that this vehicle is equipped with front airbags and the related precautions shall be observed.



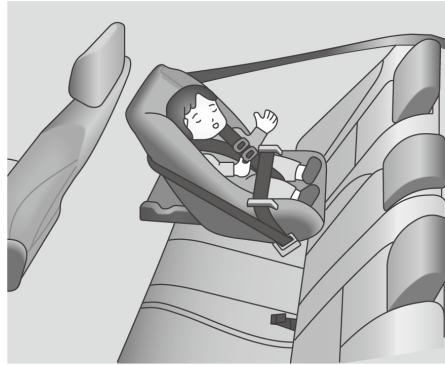

- Do not use rearward child restraint system at the seat that is under front airbag protection (in activated state)!
- Do not put a rearward child restraint system on a front passenger seat. Infants and younger children will be severely injured or killed when the airbag is inflated if they cling to or are too close to the airbag. ◀

## Installation of Seat Belt Based Rear-facing CRS

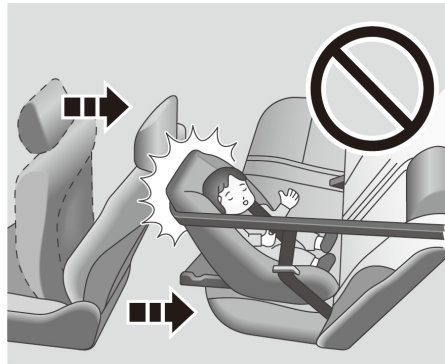

Example of a rear-facing child restraint system installed in the rear seat of vehicle.



 If installation of child restraint system obstructs mechanical locking device of front seat, the child restraint system should not be installed in the rear seat. Otherwise it will cause severe injuries and even death to the child and the front passenger in case of an emergency braking or collision. If there is not enough space behind the driver seat to install the child restraint system, please install it in the left rear seat. ◀



Below is a generic method to install a rear-facing seat belt based child restraint system. PROTON recommends child restraint system is installed according to the manufacturer handbook. Pass the three-point seat belt through or embrace around the child restraint system, insert the latch into the buckle and do not twist the seat belt according to instructions of the child restraint system. Keep the lap belt uptight.



Be sure to confirm latch and buckle are locked and the seat belt is not twisted after the latch is inserted.

Do not insert any coin or clip etc. into the buckle to avoid obstructing the latch being inserted into the buckle properly. If the buckle is not functioning properly, immediately contact the authorised PROTON e. MAS service outlet for inspection and repair. Do not use the seat before the buckle is fixed, as it cannot play a role in protecting the passengers or the child. ◀

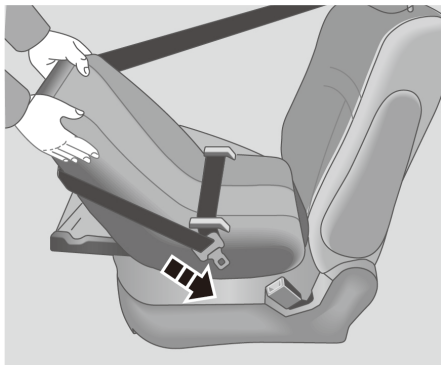

Push or pull the child restraint system from different directions to confirm it is firmly fixed.

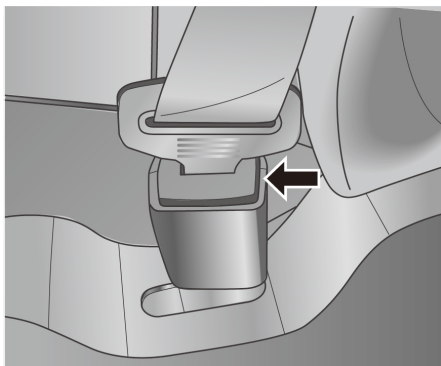

To remove the child restraint system, press the release button of the buckle.

## Installation of Seat Belt Based Forward-facing CRS

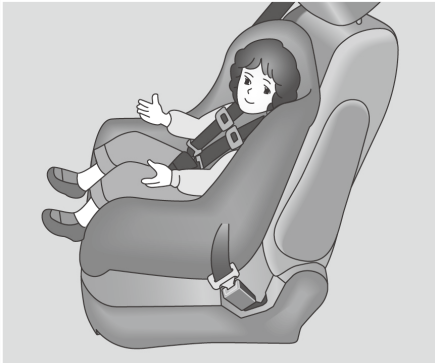

Below is a generic method to install a front-facing seat belt based child restraint system. PROTON recommends child restraint system is installed according to the manufacturer handbook.

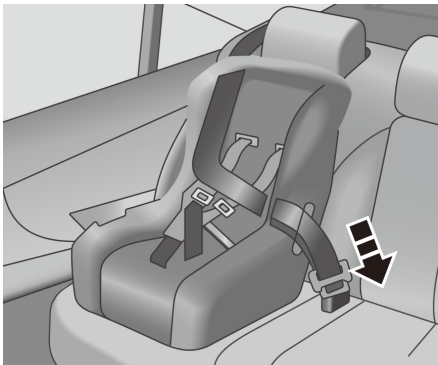

Pass the lap belt and the shoulder belt through or around the child restraint system, insert the latch into the buckle, do not twist the seat belt and tighten the lap belt.

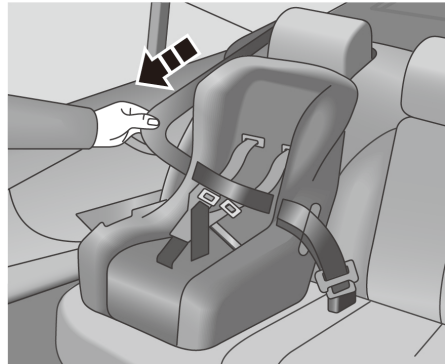

Pull the shoulder belt fully to locking state and it cannot be pulled out when the shoulder belt retracts a little. Before the seat belt retracts, please make sure it is getting into locking state, so as to fix the child restraint system firmly in place.

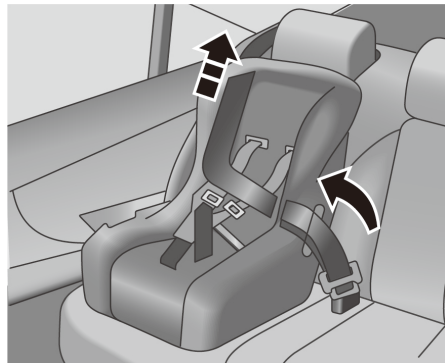

When pressing the child restraint system to the cushion and the backrest, let the shoulder belt retract completely to fix the child seat firmly.

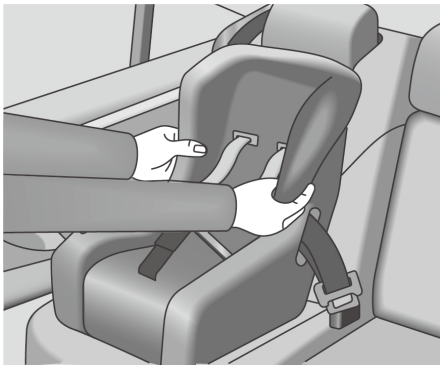

Push or pull the child restraint system from different directions to confirm it is firmly fixed and it must be installed according to the instructions provided by manufacturer.

### Installation of Booster Seat

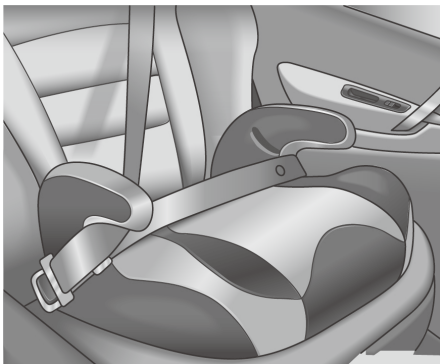

Below is a generic method to install a booster seat child restraint system. PROTON recommends child restraint system is installed according to the manufacturer handbook.

Put the child in the child safety seat, pass the lap belt and the shoulder belt through or around the child, insert the latch into the buckle and do not twist the seat belt according to instructions of the child restraint system.

Confirm that the shoulder belt passes through the shoulder of child, and try to keep the lap belt as low as to the hip/lap of child. Please refer to Section "Seat Belt" in this Chapter for details. To remove the child restraint system, press the release button of the buckle. Let the seat belt retract back, and the seat belt will be functioning as usual.



Make sure the shoulder belt is at the middle of child's shoulder. Keep the seat belt away from the neck of child but do not have the seat belt be located below child's shoulder. Otherwise, the protective effect may be reduced and serious injuries may be caused in an accident.

An incorrect positioned lap belt (positioned higher than child hip) and a loose fitting seat belt may cause serious injuries in a collision. Confirm the lap belt is kept as low as to the hip/lap of child. For child's safety, do not put the shoulder belt below the child's arm. ◀

### Installation of ISOFIX Child Restraint System

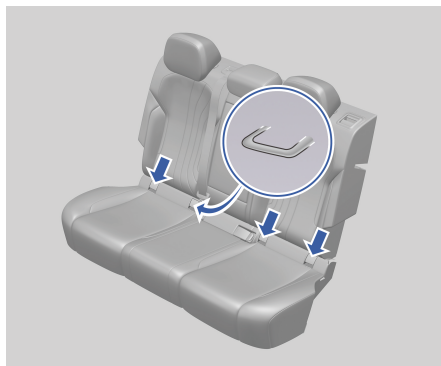

Dedicated ISOFIX mountings are located in the rear end of the rear seat cushion. These mountings are used to install the ISOFIX

child restraint system on the rear seat. It is not necessary to install the child restraint system with a seat belt at this time. When installing and using the ISOFIX child restraint system, please follow the instructions of the manufacturer. Otherwise, the protection effectiveness may be affected.

 Confirm with the manufacturer whether the child restraint system can be used for this type. ◀

Install the child restraint system to the as follows:

1. Lower the headrest of the rear seat to its lowest position;

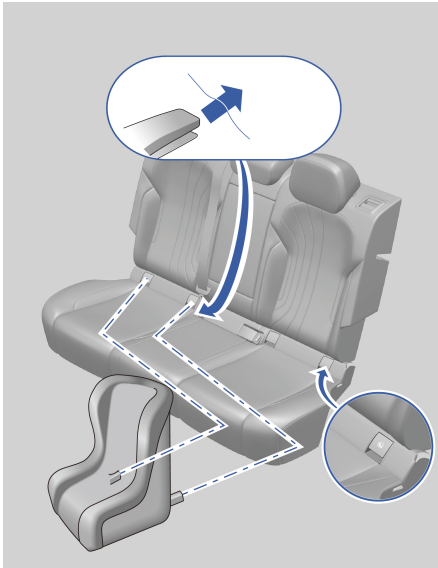

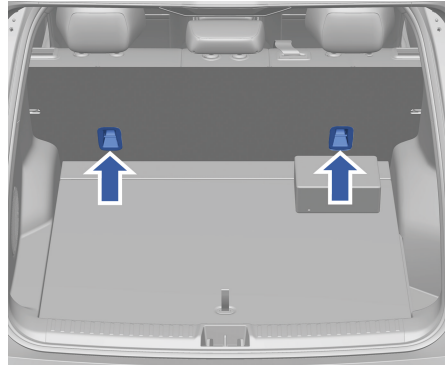

2. Confirm the position of the ISOFIX anchorage mountings in the rear end of the rear seat cushion;
3. Align the ISOFIX connector of child restraint system with the corresponding ISOFIX mountings and insert it;

4. Confirm that the low anchorage is buckled firmly;



5. Confirm the position of the top tether ISOFIX anchorage on the back of the seatback of rear seat;
6. Align the top tether ISOFIX connector of child restraint system with the corresponding top tether ISOFIX mountings and insert it;
7. Confirm that the top tether anchorage is buckled firmly;

 Confirm that the top tether anchorage is buckled firmly. Push and pull the child restraint system in different directions to check whether it is secured. Installation shall be carried out according to the instruction of manufacturer. ◀

 If the child restraint system is not installed to the ISOFIX anchorage mountings correctly, it may not work properly. Severe injury or even death may occur to the child. When mounting a child restraint system, make sure to strictly follow the instructions of manufacturer.

The ISOFIX anchorage mountings are designed only to carry the load imposed by the proper installed ISOFIX child restraint

system. In any case, it must not be used as a seat belt, a place to tie things and other devices to be attached to a vehicle.

Install the child restraint system only when the vehicle is stationary. When the ISOFIX child restraint system is correctly installed to the ISOFIX anchorage mountings, a “click” sound will be heard. ◀

## Child Safety Lock

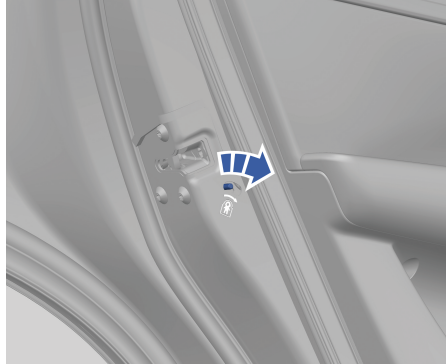

The left and right rear doors are fitted with child safety locks. Please use child safety locks when rear seats are occupied with children.

The child safety lock switch is located on the outer edge of rear door; toggle the safety lock switch in the arrow direction as shown in the figure, then the child safety lock will be in lock position at this moment; the door cannot be opened from the inside but can be opened from the outside to protect the safety of children.



After setting the child safety lock, confirm whether the rear door can be opened or not from inside to make sure the child safety lock works normally. ◀

## Car Search Mode

If you forget where you have parked your vehicle, use the car search mode function: To find the vehicle, press the lock/car search button of the intelligent key twice in a row.

### Setting of Car Search Mode

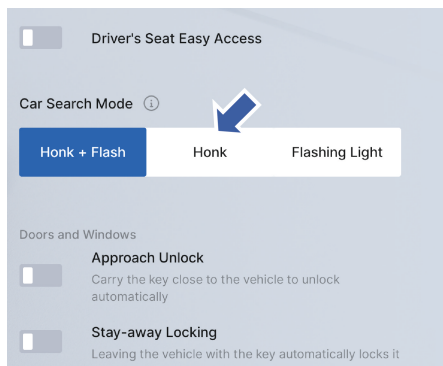

Click the following on the multimedia display in sequence: Vehicle Settings → Vehicle Control → Preferences → Car Search Mode and set your desirable warning of the Car Search Mode which includes Horn + flash, Whistle, Flash.

## Intelligent Key

### Introduction to Key Buttons

The intelligent key has been matched with the vehicle system. If the intelligent key is lost, damaged or stolen, contact an authorised PROTON e.MAS service outlet immediately to cancel the control functions such as starting, unlocking and locking. If the intelligent key is retrieved, PROTON e.MAS service outlet can reactivate it.

**i** A new intelligent key cannot be provided immediately; It takes sometime for PROTON e.MAS service outlet to match a new intelligent key with the vehicle. ◀

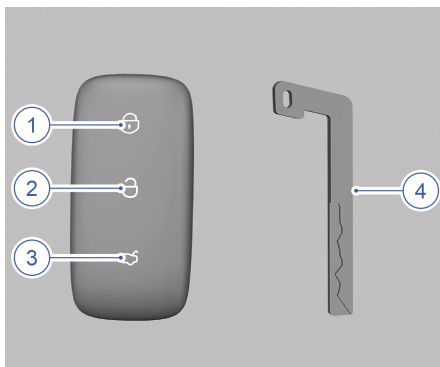

1. Locking/car search button
2. Unlocking button
3. tailgate unlocking button
4. Mechanical key

### Remote Locking

When you briefly press the locking/car search button of the intelligent key, all doors will lock, the locking prompt will sound, the turn signal will flash, the interior lamps will go out, and the infotainment system will turn off. If either door is not closed, the door will

not lock when you press the locking/car search mode button on the intelligent key.

Click the following on the multimedia display in sequence: Vehicle Settings → Sound → Prompt Sound, and then enable or disable the locking prompt sound in the interface.

### Remote Unlocking

Briefly press the unlocking button on the intelligent key to unlock the all doors or driver door, and the turn signal will flash twice. Briefly press the tailgate unlocking button to unlock the tailgate. If equipped with a power tailgate, press and hold the tailgate unlocking button and the tailgate will open automatically.



Do not let children from entering the luggage compartment. Make sure the tailgate is closed when the vehicle is unattended. If a child is trapped in the luggage compartment, it is likely that he or she will not be able to escape and will end up in heat stroke or other unintentional injuries. ◀



- Please keep the spare intelligent key in a safe place but not in the vehicle.
- Equipment with built-in anti-theft chip may cause interference to the intelligent key system and the anti-theft system of the vehicle; These systems may work abnormally and the vehicle possibly cannot be started. ◀

### Setting of Remote Unlocking Function

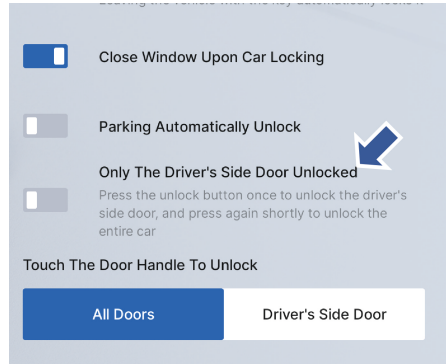

Click the following on the multimedia display in sequence: Vehicle Settings → Vehicle Control → Doors and Windows. Then, enable or disable the function of driver door unlocking only in the interface.

- After this function of driver door unlocking only is enabled, briefly press the unlocking button on the intelligent key once will only unlock the driver door. It is necessary to briefly press the intelligent key unlocking button again within a certain period of time to unlock all doors.
- After this function of driver door unlocking only is disabled, briefly press the unlocking button on the intelligent key once to unlock all doors.



If the intelligent key is interfered by other signals, the vehicle may not be able to detect the intelligent key for starting, unlocking and locking, etc.

- Placing the intelligent key together with metal shielded item, for example, mobile phones with a metal housing.
- Placing the intelligent key besides the standby power supply or within the range

of interference when external devices and equipment are operated by the standby power supply.

- Put the intelligent key besides or together with electronic devices that cause strong interferences (such as laptops, Bluetooth headsets, working power converter and charger, Bluetooth access cards, walkie talkies and other similar devices with strong interferences). ◀

 Do not change the transmitting frequency or increase the transmitting power without authorisation (including installing additional transmitting frequency amplifiers), and do not connect the external detection antenna or use other transmitting detection antennas without authorisation.

When you open the door with the mechanical key and if the anti-theft alarm is triggered, it is necessary to use the intelligent key to unlock the door. ◀

## Vehicle Locking and Unlocking

### Intelligent Entry System

#### Keyless Unlocking

##### Type 1

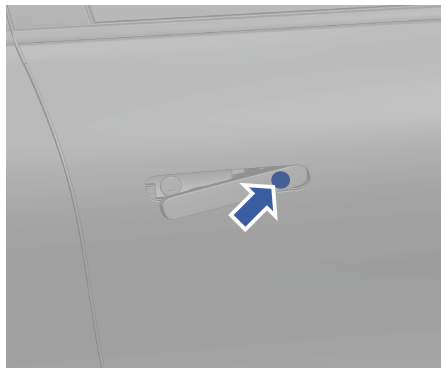

Unlocking sensor area

When the touching the door handle function on the multimedia display has been set to unlock all doors; Bring the valid intelligent key into the keyless entry operating range and touch the sensor area at the door handle to unlock the door. All doors will automatically unlock and all door handles will pop out. Pull the pop out part of the door handle to open the door and the turn signals will blink.

## Type 2

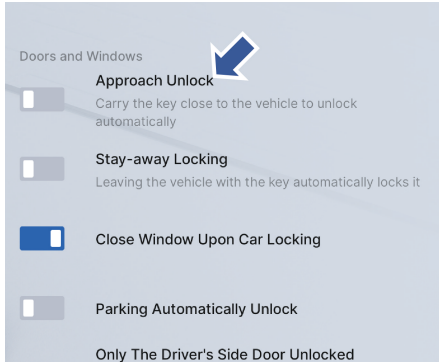

Click the following on the multimedia display in sequence: Vehicle Settings → Vehicle Control → Doors and Windows, and then enable the close to unlock function in the interface. After close to unlock function is enabled; When the vehicle is locked, just bring the valid intelligent key into the keyless entry operating range. All doors will automatically unlock and all door handles will pop out. Pull the pop out part of the door handle to open the door and the turn signals will blink.

## Setting the Keyless Entry Function

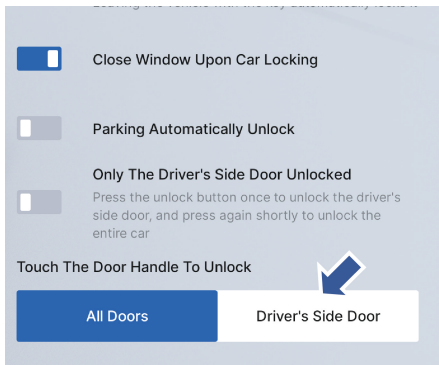

Click the following on the multimedia display in sequence:

Vehicle Settings → Vehicle Control → Doors and Windows → Touch the door handle to unlock, and then select All Doors or Driver's Side Door in the interface.

- All Doors: After the Touch the Door Handle to Unlock function is set to All Doors, when you touch the unlocking sensor area on the driver door handle, all doors will unlock automatically.
- Driver's Side Door: After the Touch the Door Handle to Unlock function is set to Driver's Side Door, when you touch the unlocking sensor area on the driver door handle, only the driver doors will unlock automatically; Other doors will remain locked.

## Keyless Locking

### Type 1

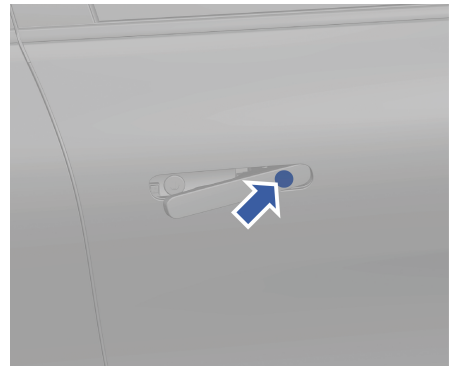

Locking sensor area

After closing all doors and tailgate, touch the locking sensor area on the driver door handle to lock all doors. After successful locking, the turn signal will flash, the locking prompt sound will sound (locking prompt sound function on) and the interior lamp will fade out.

## Type 2

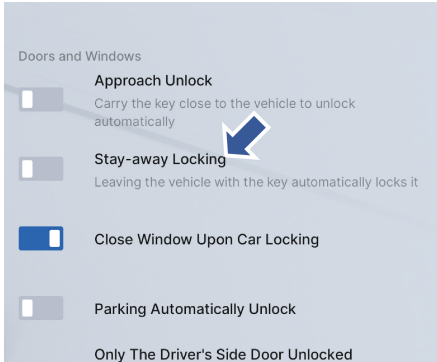

Click the following on the multimedia display in sequence: Vehicle Settings → Vehicle Control → Doors and Windows, and then enable the Stay-away Locking function in the interface. When Stay-away Locking function is enabled, the vehicle is in unlocked state and all doors are closed, if the driver walk away from the vehicle with a valid intelligent key, the vehicle will be locked, the turn signal will flash and the locking prompt sound will sound (if locking prompt sound function on).



Keyless locking fails if:  
The vehicle is not powered off.

- The vehicle is not powered off.
- Any door is not closed.

The following conditions may affect the Stay-away Locking function:

- The intelligent key may be interfered when the vehicle is in a charging station, a large parking lot, a substation, and other places with signal interference, or when the intelligent key is put together with the equipment that can cause signal interference (such as mobile phones, Bluetooth devices, computers and inverters). Consequently, abnormal key functions, such as unlocking or locking abnormalities will be observed occasionally. If this happens, wait for while before placing hand on the door handle unlocking or locking sensor area for unlocking or locking.
- When the intelligent key is in an area close to the vehicle for a certain period of time, in order to save the power consumption of the vehicle, the Stay-away Locking function may automatically turn off. Unlock the vehicle or open/close the door to reactivate the Stay-away Locking function.
- After turning on the Close to Unlock or Stay-away Locking function, leave the vehicle only after confirming that the vehicle has been successfully locked. ◀
- The intelligent key only works within the operating range of keyless entry system. Please note that its operating range is sometimes affected by physical and geographic factors. For safety concern, it is necessary to check whether the operation succeeds when locking the vehicle.

## Central Locking and Unlocking



Central Lock Switch

When all doors are closed and in unlocked condition, if you press the central lock switch, all doors will lock.

When all doors are locked and if you press the central lock switch, all doors will unlock.

**i** The unlocking prompt by using central lock switch inside the vehicle can only be executed in the condition that the anti-theft system is disabled. ◀

## Automatic Locking and Unlocking

### Automatic Re-locking

When the vehicle anti-theft system is in the armed condition and you press the unlocking button of the intelligent key, if you do not open any doors and tailgate, all doors and tailgate will be automatically locked again. The interior lamps will fade out and the anti-theft system will be armed again.

### Automatic Locking During Driving

When starting the vehicle and the vehicle speed reaches more than 7 km/h, all door will automatically lock.

### Automatic Unlocking When Parking

Click the following on the multimedia display in sequence: Vehicle Settings → Vehicle Control → Doors and Windows, and then enable or disable the automatic unlocking when parking function in the interface. After the automatic unlocking when parking function is enabled; While the vehicle is in locked condition and you stop the vehicle, place the gear in Park (P) position; All doors will automatically unlock.

### Collision Unlocking

In case of severe collision while driving and the system detects a collision signal, all doors will automatically unlock to allow the occupants to leave the vehicle quickly. This automatic collision unlocking depends on how strong the impact force is and the severity of the accident.

## Door Handle

### Unlocking via Door Handle

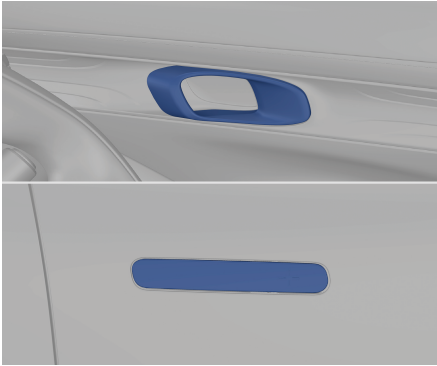

When the doors are unlocked, pull the interior and exterior door handles of the vehicle to open the door.

## Driver Easy Access\*

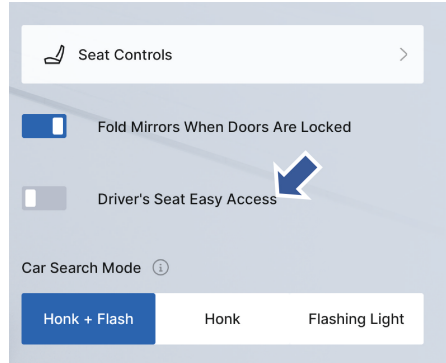

Click the following on the multimedia display in sequence: Vehicle Settings → Vehicle Control → Preferences, then turn on or off the driver easy access function in the interface.

- Comfortable exit: Open the driver door and the driver seat will automatically move backwards for easy exit.
- Comfortable entry: Open the driver door and the driver seat will automatically move backwards for easy entry. Close the driver door and the seat will automatically return to its memory position.

 During the operation of driver's easy access function, changing the vehicle power mode on/off and manually adjust using the switches to adjust the seat will interrupt the driver's seat easy access function.



## Opening and Closing the Tailgate

### Opening the Tailgate

 When you manually open or close the tailgate, please be gentle (open or close slowly). Failure to do so may result in damage or malfunction of the tailgate. ◀

### Opening the Tailgate from Inside\*

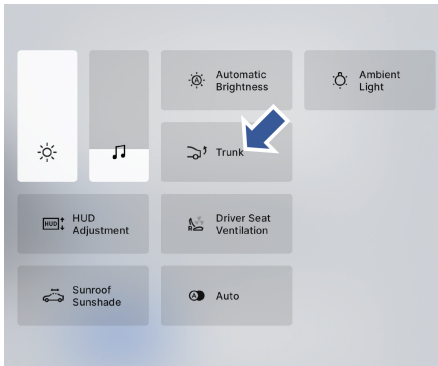

Trunk Button (tailgate button)

**Via multimedia display:** When the tailgate is in closed condition, from the top part of the multimedia display, scroll down to access the shortcut panel and then click the trunk button to open the tailgate. The trunk button on the multimedia display will be highlighted.

**Via multi control function button:** When the tailgate is in closed condition, if the multi control function button on the steering wheel has been set to tailgate control and when you press and hold the multi control function button on the steering wheel, the tailgate will open.

### Opening the Tailgate from Outside

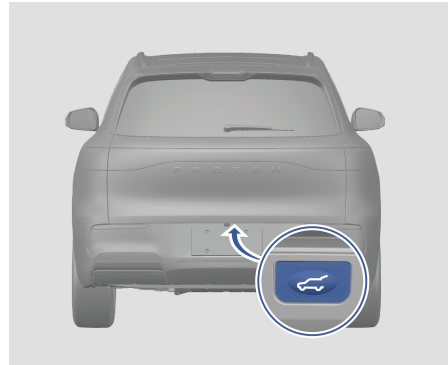

External Tailgate Switch

When the vehicle is stationary, the anti-theft system is disabled and the vehicle is unlocked, press the external tailgate switch as shown in the illustration and the tailgate will open.

When the vehicle is locked and the intelligent key is near the tailgate, press the external tailgate switch to open it.

### Unlocking the Tailgate with Intelligent Key

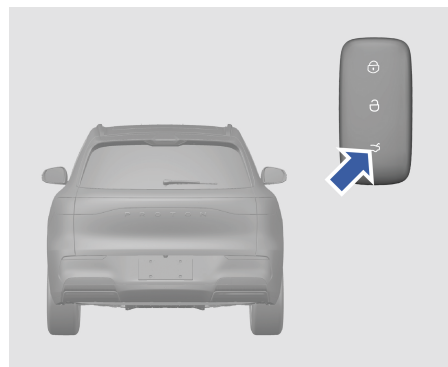

When the vehicle power mode status is in OFF or ACC position, briefly press the

tailgate unlocking button on the intelligent key to unlock the tailgate. Then, press the external tailgate switch to open the tailgate. For models equipped with power tailgate, press and hold the tailgate unlocking button on the intelligent key. The tailgate will unlock and automatically open to the set height.

### Tailgate Opening Height Setting\*

#### Setting via the Tailgate Closing Switch

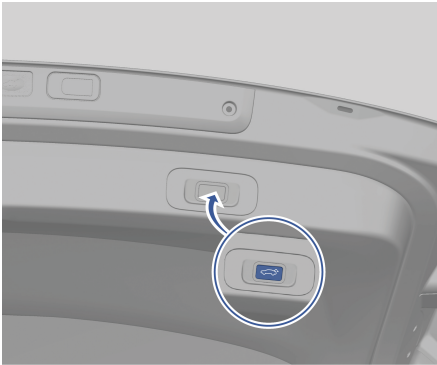

1. When the tailgate is moving to open, press the tailgate closing switch on the edge of the tailgate door to suspend the current opening movement of the tailgate.
2. Press and hold the tailgate closing switch on the edge of the tailgate door until you can hear two beeps that confirms the opening height of the tailgate has been successfully set. Next time, when you open the tailgate, the tailgate will open until the newly set opening height.
3. To adjust the opening height of the tailgate opening, push the tailgate door up or down manually, and repeat previous step 2. The opening height of the tailgate will be reset.

#### Setting via the Multimedia Display

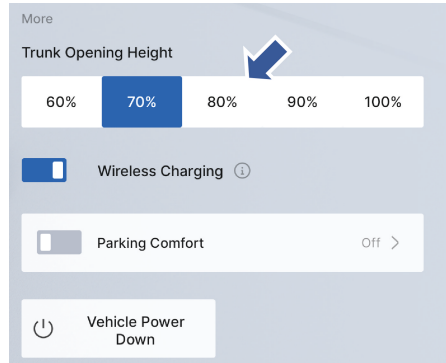

Click the following on the multimedia display in sequence:

**Vehicle Settings** → **Vehicle Control** → **More** → **Trunk Opening Height** to set the tailgate opening height in the interface.

### Closing the Tailgate\*

#### Closing the Tailgate from Inside

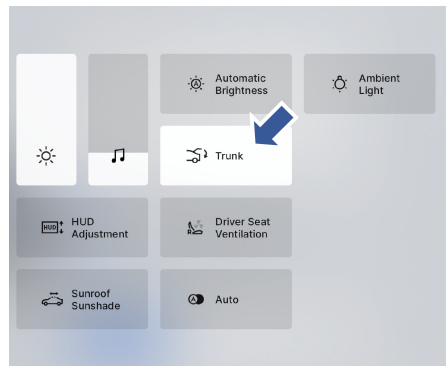

**Via multimedia display:** When the tailgate is in open condition, from the top part of the multimedia display, scroll down to access the shortcut panel and then click the high-lighted trunk button on the shortcut panel to close the tailgate. The trunk button on the

multimedia display also will be no longer highlighted.

**Via multi control function button:** When the tailgate is in open condition, if the multi control function button on the steering wheel has been set to tailgate control and then you briefly press the multi control function button on the steering wheel, the tailgate will close.

### Closing the Tailgate from Outside

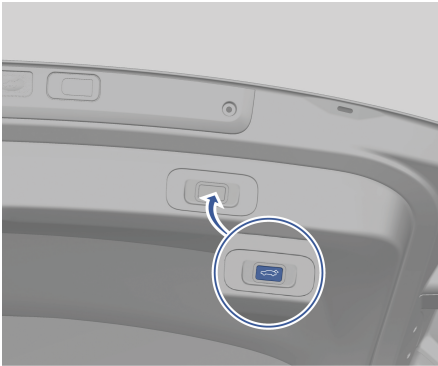

When the vehicle is stationary and the tailgate is open, press the tailgate closing switch on the edge of the tailgate door to close the tailgate.

### Tailgate Follow-up Function

When the vehicle is stationary and the tailgate is open, manually push the tailgate upward or downward, and the tailgate will automatically open or close respectively.

### Tailgate Delayed Closing

When the vehicle is stationary and the tailgate is open, if the you carry the intelligent key and press the tailgate closing switch

twice consecutively, the tailgate will activate the delayed close function (beeping sound).

If you carry the intelligent key away from the rear of the vehicle at certain distance, the tailgate will close.

If you carry the intelligent key and continue stay within the keyless system operating range, the tailgate will close after a certain period of time.

### Tailgate Closing via Intelligent Key

When the vehicle is stationary and the tailgate is open and you press and hold the tailgate unlocking button on the intelligent key, the tailgate will close automatically.

**THIS PAGE IS INTENTIONALLY LEFT BLANK**

## Anti-theft System

This vehicle is equipped with an anti-theft system. The anti-theft system automatically disarms when the brake pedal is depressed, the gear is not in Park (P) position and a valid intelligent key is detected in the vehicle.

If neither of the following two methods can start the vehicle, your vehicle needs repair. Contact an authorised PROTON e. MAS service outlet for a new intelligent key.

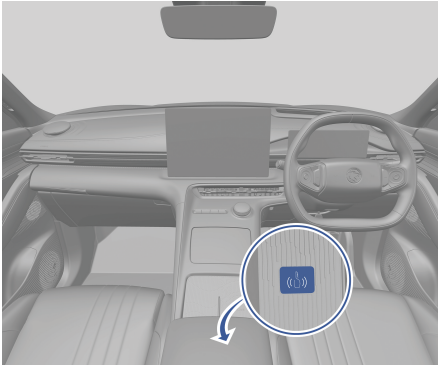

- Put the intelligent key at the key mark area in the storage box of front centre armrest.
- If the intelligent key appears to be damaged, try using the spare intelligent key.

 Do not leave the intelligent key or devices that can disable the anti-theft system in the vehicle. ◀

## Anti-theft Alarm System

The anti-theft alarm system is a system that generates an audible and visual alarm when the risk of vehicle theft is detected. The anti-theft alarm system will enter the arming condition 30 seconds after the vehicle has been locked.

 When in the armed condition, the anti-theft alarm will be triggered when any

doors, front compartment hood or tailgate are not opened in a proper manner.

The triggered anti-theft alarm system can be turned off in any of the following ways:

- Start the vehicle (with a valid intelligent key in the keyless entry operating range).
- Unlock the vehicle with a valid intelligent key. ◀

## Front Storage Compartment

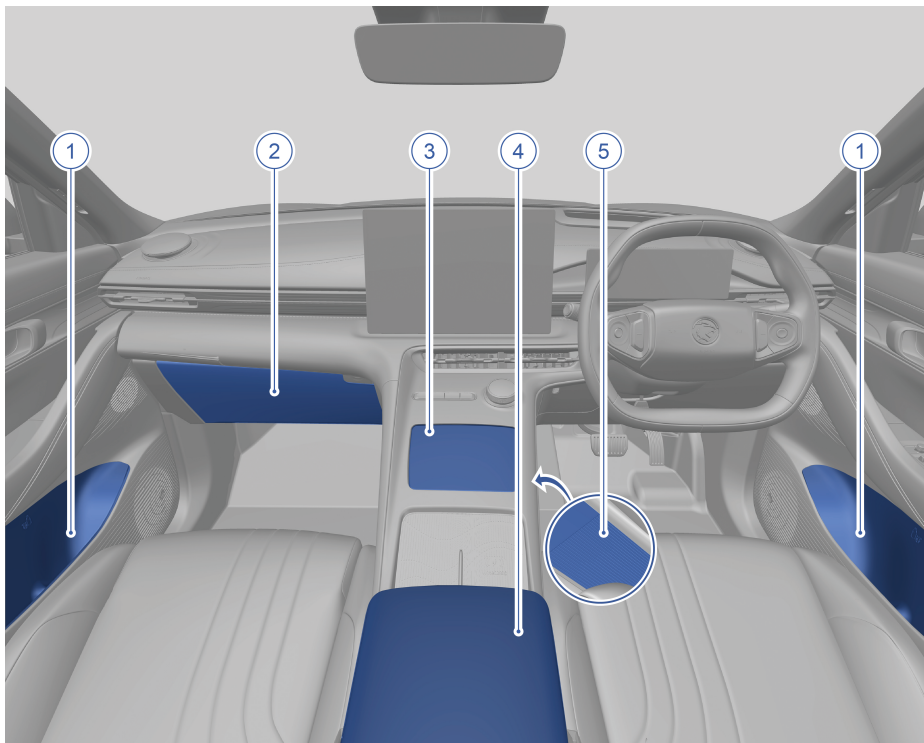

1. Door storage compartment
2. Glove box
3. Front cup holder
4. Front centre armrest storage box
5. Lower storage box of sub instrument panel

### Center Armrest Opening/Closing

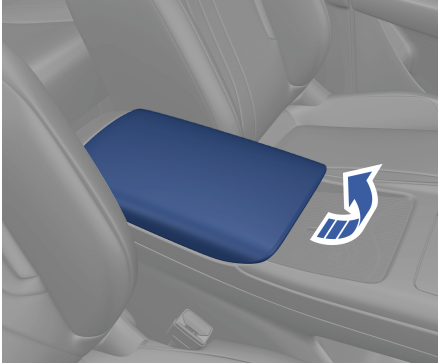

A storage box is designed under the front center armrest, which can be seen by flipping up the center armrest.

 Never open the storage box under the center armrest during driving. ◀

### Opening and Closing the Glove Box

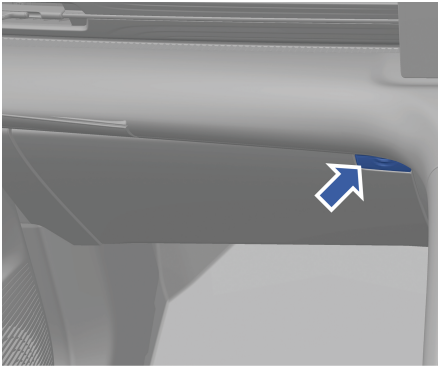

Press the opening button of the glove box to open the glove box.

Push forward the cover of the glove box to close the glove box.

### Opening and Closing the Front Cup Holder

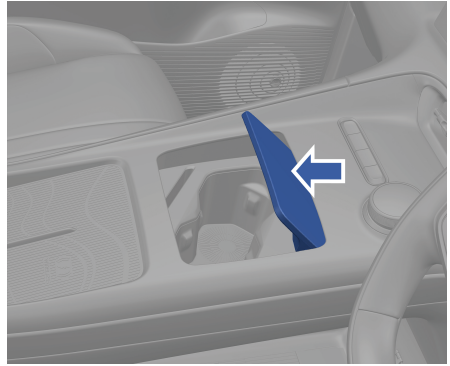

Press down the front cup holder cover to open the cover and store drink cans, bottles or cups in the front cup holder.

 When the cover of front cup holder is opened, any foreign objects on top of the cover can easily slip and fall into the hole of centre console. At the back of the hole of centre console below the front cup holder is designed with a blocking cover. In case any foreign objects fall off, they can be retrieved from the hole after opening the cover. ◀

## Rear Storage Compartment

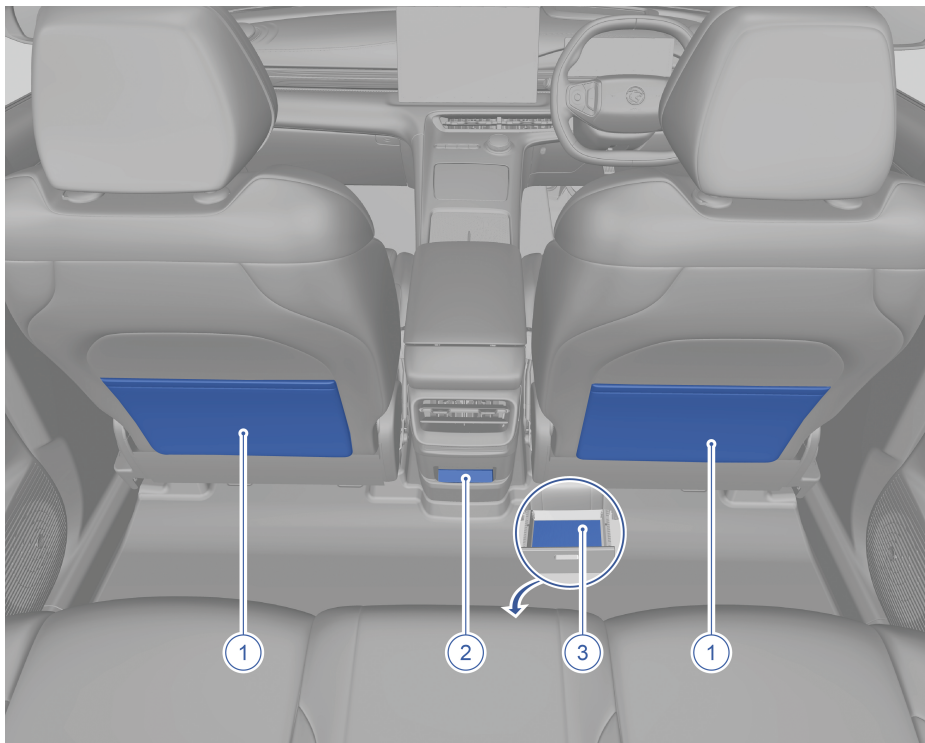

1. Rear seatback pocket
2. Rear storage compartment of centre console
3. Rear seat storage compartment

The rear seatback pocket is located on the back of front seat and can be used to keep small objects like newspaper, maps etc.

 Do not put heavy or sharp objects in the rear seatback pocket to avoid damage to the rear seatback pocket. ◀

The rear seats storage compartment is located under the rear seats and can be used after opening.

### Rear Centre Armrest

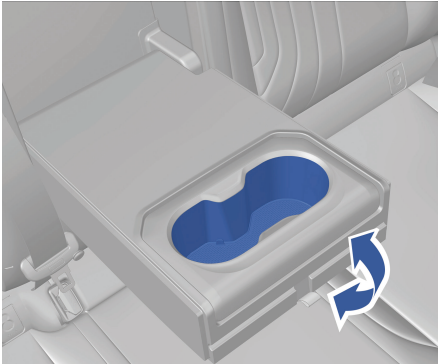

The rear centre armrest is located in the middle of rear seatbacks and can be used by flipping it downward completely. The rear cup holder can be used to store drink cans, bottles and cups.

Restore the rear centre armrest to its upright position when not in use.

## Luggage Compartment

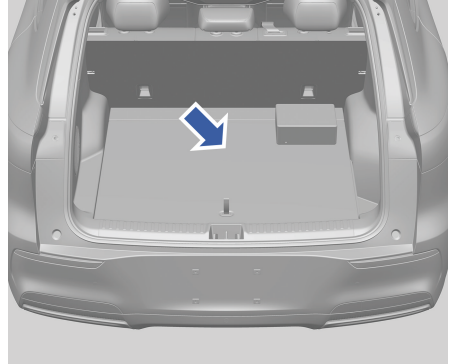

When the tailgate is opened, objects can be loaded in the luggage compartment space and the luggage compartment lamp will automatically illuminate.

 Do not leave pets in the trunk to avoid accidental injury. ◀



- If the weight of the loaded goods exceeds the loading capacity of the vehicle, or the weight distribution of the vehicle is uneven after being loaded, the driveability of the vehicle and the driving safety will be severely affected. In case of a traffic accident or emergency braking, the stored objects in the loading area will move. Try to place the objects at lower and utmost front position; namely, place them as close as possible to the back of the rear seatback.
- When loading a tall or large object, the size of the object must not exceed the height of the front seatback and the luggage compartment. Make sure to securely place the object in the vehicle to ensure driving safety. ◀

## Roof Rail

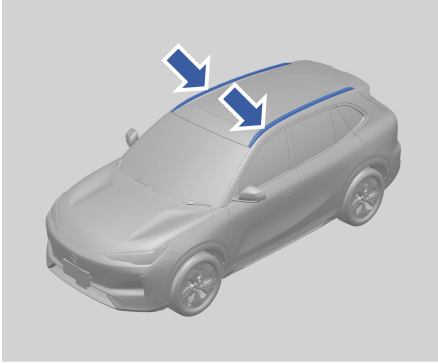

This vehicle is equipped with a load-bearing type of roof rail and can be used to store luggage up to a maximum load of 50 kg.



- Only a roof rack system that are suitable for this vehicle can be used, along with appropriate fixing devices (including accessories such as crossbars to assist with the load). Ensure that objects loaded on the roof rack system using the vehicle roof rail do not interfere with the operation of the sunroof (if equipped).
  - The objects loaded on the roof rack system using the vehicle roof rail must be fastened firmly; Otherwise, there is a risk of accidents.
  - Do not overload the roof rack system using the vehicle roof rail or exceed the approved gross vehicle weight.
  - The objects loaded on the roof rack system using the vehicle roof rail will raise the center of gravity of the vehicle. Avoid high-speed driving, sudden acceleration, emergency braking and sharp turning.
- When large objects are transported on the roof rack system using the vehicle roof rail, the vehicle handling and steering response will change, increasing the risk of accidents.
  - When installing the roof rack system using the vehicle roof rail or carrying objects using the roof rack system attached to the roof rail, strictly observe the relevant requirements of local traffic regulations.

**THIS PAGE IS INTENTIONALLY LEFT BLANK**

## Adjustment of Driver Seat



Do not adjust the seats while driving. Otherwise, the vehicle may lose control and cause personal injury or even death. ◀



- When driving, do not incline the seatback too much to avoid personal injury or even death in case of collision.
- In the event of a vehicle accident, the seat belt can provide maximum protection only when the occupant maintain the correct sitting posture. ◀

## Electric Adjustment of Driver Seat



Do not place any object under the driver seat that can obstruct the movement of the seat. Otherwise, the seat adjustment motor may be damaged. ◀

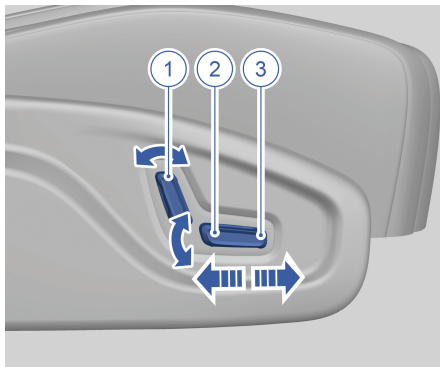

1. Move the switch forward or backward to adjust the angle of the seatback.
2. Move the rear end of the switch up or down to adjust the height of the seat cushion.

3. Move the switch forward or backward to adjust the front and rear positions of the seat.

## Electric Adjustment of Driver Seat via Multimedia Display

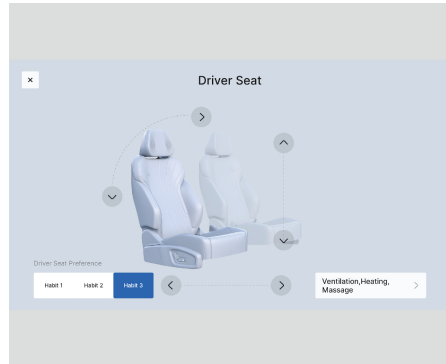

For some models, you can click the following on the multimedia display: Vehicle Settings → Shortcut → Seat Adjustment in sequence and then adjust the driver seat in the seat adjustment interface.

## Seat Memory Function of Driver Seat\*

For some models, there is a seat memory function equipped for the driver seat.

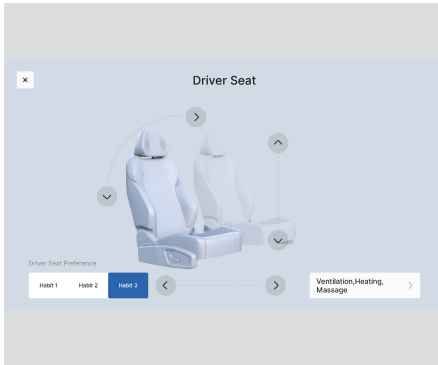

1. Click the following on the multimedia display: Vehicle Settings → Shortcut → Seat Adjustment in sequence and then enter the seat adjustment interface;
2. Adjust the front and rear position of the driver seat, the angle of the seatback and the height of the seat cushion to the appropriate position of the driver seat;
3. Click the Save button to refresh the seat memory; Click the restore button to restore the original seat memory;

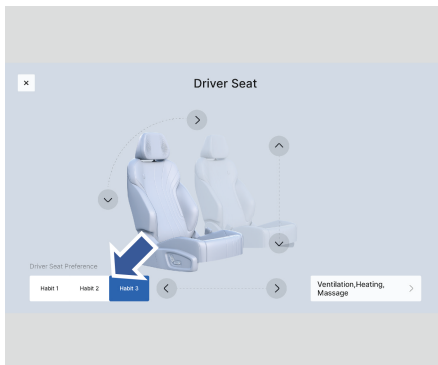

4. Click Save to record up to three vehicle preferences;

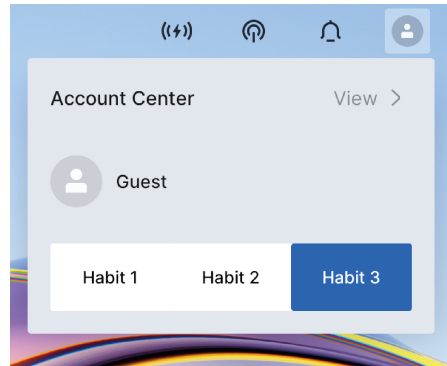

5. Click the Account Center avatar in the status bar of the multimedia display to switch between the recorded vehicle preferences.



- When the driver seat is manually adjusted through the physical electric adjustment buttons of the driver seat, the multimedia display will automatically pop up the seat memory interface.
- When the seat memory is not saved or restored, the current adjusted seat position is retained but not memorized
- When the vehicle power mode status is in ON position, the vehicle speed should be less than 5 km/h to start the seat memory function. ◀

## Horn



Press the horn icon area on the steering wheel and the horn will beep.

## Adjustment of Steering Wheel

 Do not adjust the steering wheel while the vehicle is in motion; Otherwise, this may cause personal injury and property damage. ◀

 After adjusting the steering wheel position, confirm whether the steering wheel is locked properly; Otherwise, this may cause personal injury and property damage. ◀

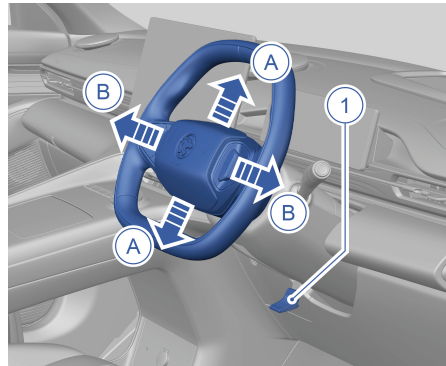

1 – Steering wheel locking lever

Follow these steps to adjust the steering wheel to a proper driving position:

1. Adjust the driver seat to a proper driving position.
2. Turn the steering wheel to the front straight-line running position.
3. Fully release the steering wheel locking lever.
4. Use both hands to firmly hold the steering wheel and adjust the steering wheel position back and forth (direction B), up and down (direction A) to a proper driving position.
5. Fold the steering wheel locking lever to lock steering wheel in its new position.

## Setting of Steering Power Assist Mode

 Choose the appropriate steering power assist mode that suits to your driving skill and the actual road conditions.

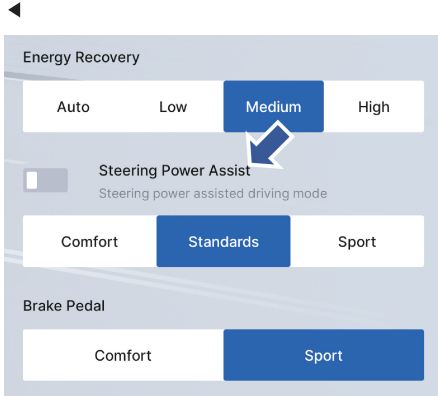

When the vehicle power mode is in ON position, click the following on the multimedia display: Vehicle Settings → Driving → Steering Power Assisted Driving mode, and then click the required steering power assist mode (between Comfort, Standard or Sport) in the interface. In addition, the steering power assist linkage driving mode function can also be turned on. After the function is turned on, the steering power of the steering wheel will match the selected driving mode.

## Steering Wheel Buttons

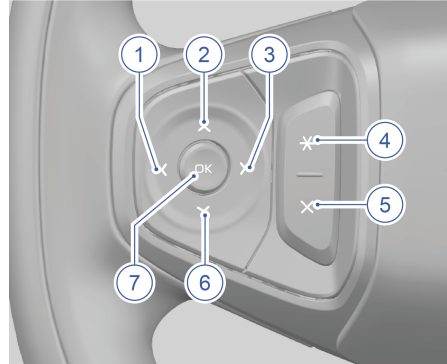

1. Headway - button: Short press to reduce the distance from preceding vehicle (only available in Intelligent Cruise Control (ICC) and Adaptive Cruise Control (ACC) functions).
2. Cruising speed adjustment and cruise control resume button:
  - Short press: cruise speed + 5 km/h per step.
  - Long press: cruise speed +1 km/h continuously.
  - Press to resume current preset cruising speed (only available in the Intelligent Cruise Control (ICC)/Adaptive Cruise Control (ACC) function).
3. Headway + button: Short press to increase the distance from preceding vehicle (only available when the Intelligent Cruise Control (ICC)/Adaptive Cruise Control (ACC) function).
4. Customised function button: Press to activate the pre-selected function (which has been selected in the button customisation multimedia display).

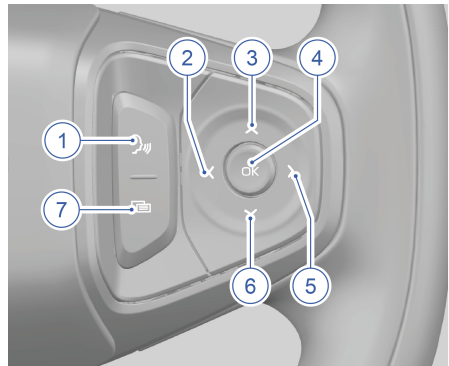
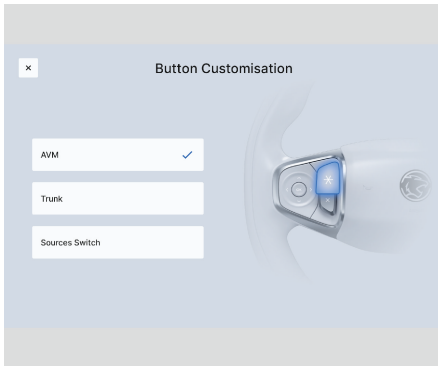

Click the following on the multimedia display: Vehicle Settings → Vehicle Control → Vehicle Preferences in sequence, and then select the custom button in this interface. Select the functions to be associated with the custom button according to your needs.

5. Cancel button: Cancel the related functions of Intelligent Cruise Control (ICC)/ Adaptive Cruise Control (ACC).
  6. Speed adjustment button:
    - Short press: cruise speed - 5 km/h.
    - Long press: cruise speed -1 km/h continuously.
  7. OK button: Press this button to activate cruise (available in the Intelligent Cruise Control (ICC)/Adaptive Cruise Control (ACC) function).
1. Voice button:
 

Short press this button to turn on the voice command function.
  2. Left button:
 

**To hang up an on-going call:** Short press the left button to hang up Bluetooth calls.

**When the meter instrument menu is closed:** Short press the left button to play previous song or channel.
  3. Up button:
 

**When the meter instrument menu is opened:** Short press the up button to switch to the previous item in the meter instrument menu.

**When the meter instrument menu is closed:** Short press the up button to increase the sound volume of the multimedia or Bluetooth phone audio source.
  4. Confirm button:
 

**When a warning interface pops up in the meter instrument:** Press the confirm button to turn off any pop up visual warning interface.

**When an audio source is playing:** Press the confirm button to pause the playback of multimedia audio source.

**When a warning interface pops up in the meter instrument:** Press the confirm button and the visual warning interface will disappear before using the right direction button of the steering wheel.

5. Right button:

**When the meter instrument menu is closed:** Short press the right button to play next song or channel.

**When there is an incoming call:** Short press the right button to answer any incoming Bluetooth call.

**During a call:** Short press the right button to turn off the microphone during a call.

6. Down button:

**When the meter instrument menu is opened:** Short press the down button to select next item in the meter instrument menu.

7. **When the meter instrument menu is closed:** Short press the down button to reduce the sound volume of the multimedia or Bluetooth phone audio source. Press and hold the down button to mute the sound volume.

8. Menu button:

Short press this button to turn on or off the meter instrument menu.

**When the meter instrument menu is opened:** The multi-control buttons of the steering wheel is set to control the meter instrument.

**When the meter instrument menu is closed:** The multi-control buttons of the steering wheel is set to control the multimedia.



AVN restart meter button: Press and hold together the voice command button and the confirm button for more than 15 seconds. At the same time, restart the meter instrument and multimedia. Considering driving safety, it can only be operated when the vehicle is in the Park (P) position and the vehicle is in the non-READY status. ◀

## Adjustment of Door Mirror



- Do not adjust the door mirrors while driving; Otherwise, personal injury and property damage may be caused.
- Make sure to unfold the door mirrors and adjust them properly before driving.
- Do not touch the door mirror glass during adjustment to avoid personal injury. ◀

### Operation using Door Mirror Adjustment Switch



The door mirror adjustment switch is on the door trim panel of the driver door.

1. When the vehicle power mode is ON, press the mark L or R on the door mirror adjustment switch to select the corresponding left and right door mirrors, and the button indicator light will illuminate;
2. Toggle the door mirror adjustment switch back/forth/left/right to adjust the angle of the door mirror glass;
3. After complete the adjustment, press the door mirror selection button again to deactivate the selection and the button indicator light will turn off.

## Folding and unfolding of Door Mirrors

### Electric Folding of Door Mirrors

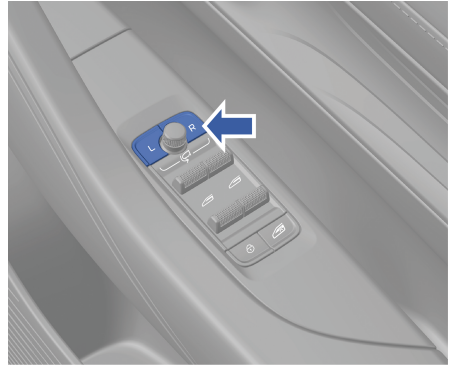

Press both L and R door mirror selection buttons simultaneously and the door mirrors will fold automatically. Press both L and R door mirror selection buttons again and the door mirrors will unfold automatically.

Frequent folding and unfolding of the door mirror may cause in temporary failure of the electric folding function. ◀

### Auto Unfolding of Door Mirrors

When door mirrors are folded, if the vehicle speed reaches more than or equal to 30 km/h, the door mirrors will automatically unfold.

### Folding of Door Mirrors when Vehicle Locking

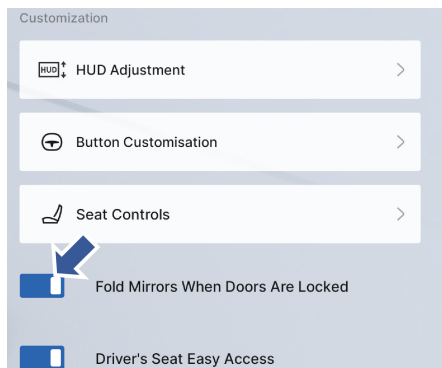

Click the following on the multimedia display in sequence: Vehicle Settings → Vehicle Control → Vehicle Preferences, and then enable or disable the function of exterior mirror folding upon car locking in the interface. After the function of folding of exterior mirror folding upon car locking is enabled, when the door mirror is unfolded, the door mirror will automatically fold after the vehicle is locked.

### Electric Heating and Defrosting of Door Mirrors



Click the A/C button on the multimedia display. After clicking the exterior rearview

mirror/rear windshield defogging<sup>™</sup> button in this interface, this button will illuminate and the door mirror will be heated. This function will automatically turn off after working for certain period. This period of time relates to the ambient temperature; The lower the external ambient temperature is, the longer the heating time is.

## Adjustment of Interior Rearview Mirror

### Adjustment of Interior Rearview Mirrors

Adjust the interior rearview mirror to required position by manually turning it.

 Do not adjust the interior rearview mirror while driving. Otherwise, severe personal injury or death or property loss may occur. ◀

### Manual Dimming of Interior Rearview Mirror

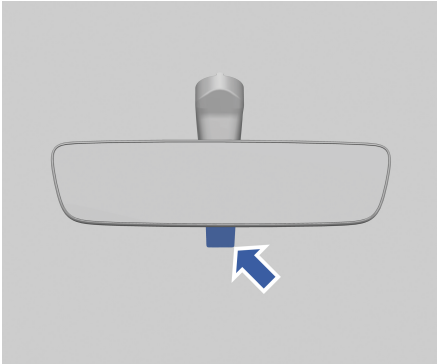

Pull the lever of the interior rearview mirror to adjust the viewing angle of the mirror for dimming purpose. Push the lever back to adjust the viewing angle back to normal driving position.

## Automatic Dimming of Interior Rearview Mirror\*

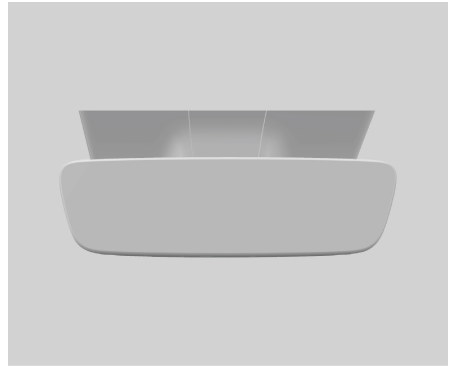

After the vehicle is started, the interior rearview mirror senses the intensity of incident light through the light sensor to trigger the automatic dimming function.

The automatic dimming function works based on the incident light coming from behind of the vehicle. The automatic dimming function automatically turns off when the vehicle power turns off or the gear shift lever is in Reverse (R) position.



- The automatic dimming function works only when the incident light at interior rearview mirror is not affected by other objects.
- Do not paste stickers or install a dashboard camera in front of the interior rearview mirror. ◀



The interior rearview mirror with automatic dimming function is equipped with light sensors. Do not hang anything on the interior rearview mirror or use glass detergent. Otherwise, the automatic dimming

function of the interior rearview mirror may not work properly. ◀

## Power Window

### Opening and Closing Windows

 Do not leave children, adults with disabilities and pets in the vehicle with closed windows and locked doors. The temperature inside the vehicle may get too high enough to cause heat stroke, resulting in personal injury or death. ◀

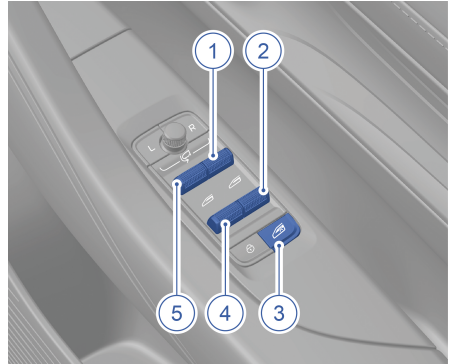

1. Front right window switch
2. Rear right window switch
3. Windows locking switch
4. Rear left window switch
5. Front left window switch

### Manual Operation of Windows

Open: push forward and hold the window switch to open the window.

Close: push backward and hold the window switch to close the window.

### Automatic Operation

Push forward or backward the window switch briefly and then release it, the window will open or close automatically. While the window is opening or closing automatically, if you push the window switch forward or

backward again, the window will stop opening or closing.

### Remote Opening and Closing of Windows

When the vehicle power is in OFF or ACC position and then you press and hold the unlocking button on the intelligent key, all windows will open at the same time.

When you press and hold the locking /car search button on the intelligent key, all windows and the sunroof (if equipped) will close at the same time.

### Windows Locking Switch

Press the windows locking switch to enable the windows locking function and the windows locking switch indicator will illuminate. At this time, the rear window switches will be disabled and only the power window control switches at the driver's side can operate to open and close the rear windows.

Press the window locking switch again to disable the windows locking function. The windows locking switch indicator will turn off.

### Automatic Window Closing while Vehicle Locking

Click the following on the multimedia display in sequence: Vehicle Settings → Vehicle Control → Doors and Windows, and enable or disable the function of automatic window closing while vehicle locking in the interface. Short press the locking button/car search button on the intelligent key; All opened windows and sunroof (if equipped) will close at the same time.

### Auto Window Closing in Rain\*

When you turn off and lock the vehicle, if it is suddenly raining, all opened windows and sunroof (if equipped) will automatically close.

 If the window/sunroof is in a condition need to be self-learned, the window/sunroof will not automatically close if raining. ◀

### Auto Window Closing When Time Out

When the vehicle power is in OFF position and the vehicle is locked for more than 12 hours, if there is any opened window or opened sunroof, the window, the sunroof and the sunroof sunshade will automatically close.

### Thermal Protection of Power Windows

If any window switch is operated repeatedly in a short time, the operation of power window control switches may halt due to the protection of the motor life of the power window system. Wait for a while before resume operating the power window switches.

 If the automatic recovery takes a long time and you need to operate the power window switches immediately, click the following on the multimedia display in sequence: Vehicle Settings → Vehicle Control → More and then click power off button in this interface and power on the vehicle to operate the power window again. ◀

### Anti-pinch Function

During the automatic closing operation, if an object is trap between the window glass and the window frame, the window closing

operation will automatically stop and return to its initial position. If the window is hit hard, there is a chance that this feature will work even if no object is caught. If the anti-pinch function of the power window system does not work properly, it is necessary to perform power window self-learning.

### Self-learning for Anti-pinch Function of Power Window

If the low-voltage battery of the vehicle is re-connected after power failure or does not work normally, it is necessary to perform self-learning for the power windows that has the anti-pinch function to enable the automatic operation and anti-pinch function..

 Make sure the low-voltage battery power has sufficient capacity before start self-learning. ◀

The self-learning steps are as follows:

1. Push and hold the power window switch backward until the window glass has fully closed to the top position. Then push and hold the power window switch backward again for more than 3 seconds before releasing it;
2. Push the power window switch forward until the window glass fully lowered to the bottom position. Then push and hold the power window switch forward again for more than 3 seconds before releasing it;
3. Push the window switch backwards until the window glass is fully raised to the top position;
4. Complete the open and close other glasses again to complete the self-learning.

5. If the power window still does not work normally after completely follow the above operations, go to PROTON e. MAS service outlet for maintenance.

## Panoramic Sunroof\*

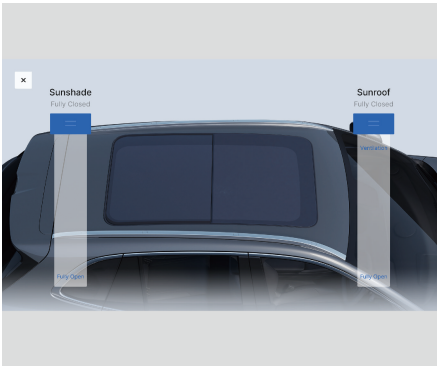
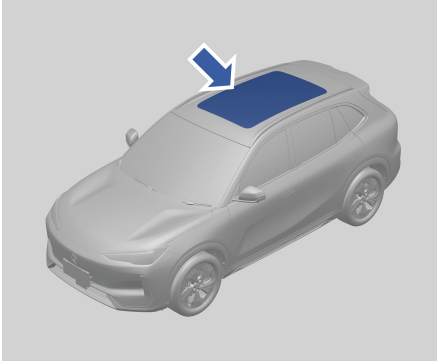

The sunroof switch is located on the multi-media display.



The following items shall be observed to avoid severe personal injuries:

- When you are driving, do not allow any occupants to be in the opening of the sunroof.
- Do not put your head or any other part of your body out of the opening of the sunroof.
- Do not leave children without supervision in the vehicle to avoid them from abusing any control switches and equipment in the vehicle.

- Do not sit around the opening of sunroof.



- The guardian should be responsible in case any accident occurs to their children related to the sunroof in the vehicle, ◀



- If an ice froze the sunroof, do not force to open the sunroof to avoid damage to the sunroof parts.
- Always clean up any excessive dust or foreign objects stuck on the glass sealant and guide rail of the sunroof. Otherwise, abnormal noise or sunroof operation failure may occur during use. ◀

### Operating Conditions of Sunroof

The vehicle power needs to be in ACC or ON position before you start operating the sunroof.

### Temperature requirement

- When the ambient temperature is between -30 ~ 85 degrees Celsius: the sunroof and sunroof sunshade are fully functional and can be operate normally, responding to the intelligent keys and voice commands.
- When the ambient temperature is lower than -30 degrees Celsius: the sunroof will tend to open or close slowly due to frost. in such condition, it is not recommended to operate the sunroof to avoid functional abnormalities due to damage of the mechanical structure of the sunroof.

## Opening and Closing of Sunroof

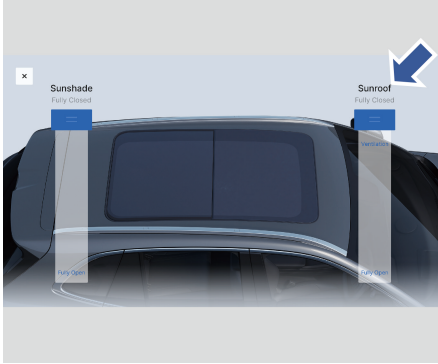

Click the following on the multimedia display: Vehicle Settings → Shortcut, and then click the sunroof icon to enter the sunroof/sunshade adjustment interface, where the sunroof/sunshade can be fully opened or fully closed. Adjust the corresponding sliding bar according to the needs, and the sunroof/sunshade will move to open/close to the required position.



- Do not squeeze the sunshade so hard with force to avoid the sunshade from damage or fall off.
- When you park the vehicle for a long time, it is recommended to close the sunshade. The best way is to park the vehicle in a garage or covered parking to prevent the temperature in vehicle from rising due to long-term exposure to the sun and damaging the interior. ◀

## Tilt opening

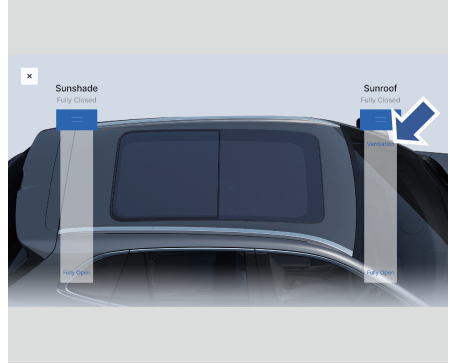

### Tilt opening

Click the following on the multimedia display: Vehicle Settings → Shortcut, click the sunroof icon to enter the sunroof/sunshade adjustment interface. Click the ventilation button under this interface, and the sunroof will tilt up to open a gap.

### Remote Closing of Sunroof

When the vehicle power is in OFF or ACC position, and press and hold the locking button/car search button on the intelligent key. The sunroof will move until it is fully closed.

## Opening and Closing of Sunshade

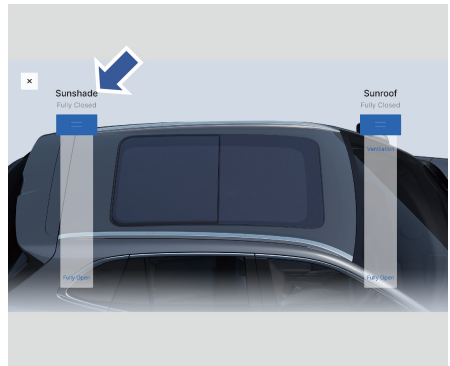

Click the sunshade fully open or fully close button on multimedia display to open or close the sunroof.

Adjust the corresponding sliding bar according to the needs, and the sunshade stays in the required position.

### Ice-breaking Function

After the anti-pinch function has been triggered once by the sunroof glass/sunroof shade, the ice-breaking function will be activated. In this situation, the anti-pinch function will no longer be supported when operating the sunroof glass/sunshade in the same direction again. To operate the sunroof and sunshade, press and hold the sunroof/sunshade switch on the multimedia display to operate the sunroof and sunshade manually. The automatic operation command of the switch will also be treated as a manual operation command.

When the following situations occur, the ice-breaking function will be disabled and the anti-pinch function will be reactivated:

- 10 seconds after the operation of the anti-pinch function has completed
- After the next operation stops.
- The sunroof/sunshade switch is operated in the opposite direction.
- Operation through remote control.

### Protection Safety anti-pinch

#### Lifting and anti-pinching

- When the sunroof glass is tilted, if it encounters obstacles, the glass will be returned to the closed position.
- When the sunroof glass is closed in the lifting position, if an obstacle is

encountered, the sunroof glass will return to the fully lifting position.

### Sunroof glass and sunroof shade anti-pinch

- If the sunroof glass or sunroof shade encounters an obstacle when it is opened in the sliding mode, it will be returned by 50mm or fully closed position.
- If the sunroof glass or sunroof shade encounters an obstacle when it is closing in the sliding mode, it will be returned by 200mm or returned to the fully open position.

 When the sunroof is running, if the anti-pinch cannot be closed or opened, press and hold the close or open button within 10 seconds after the anti-pinch return stops. At this time, the anti-pinch function and automatic operation function will be suspended, and the sunroof or sunshade will be manually closed or opened, and the action will be stopped after releasing hands. After 10 seconds, the anti-pinch function and automatic operation function will be restored. ◀

 It is necessary to check whether there are foreign objects in the sunroof guide rail first to avoid damage to the sunroof caused by forced opening or closing! ◀

### Self-learning of Sunroof

If the low-voltage battery of vehicle is reconnected after power failure or does not work properly, it is necessary to perform self-learning for the sunroof that has anti-pinch function to enable the automatic operation and anti-pinch function.

The self-learning steps are as follows:

1. Move the sunroof and sunshade to closing point;
2. Click the sunroof close button and hold it. After 10s, the sunroof will move in the closed direction and once the sunroof moves to the mechanical hard stop center (slightly vibrate), it will retract a certain distance to stop at the fully closed point. The sunshade moves in the closing direction, and the sunshade moves to the mechanical hard stop center and then retracts a certain distance to stop at the fully closed point. Keep the sunroof/sunshade switch unreleased. The sunshade stops when it reaches the fully open position, the sunroof lifts and closes, and stops when it reaches the fully open position;
3. The sunroof stops when it reaches the fully closed position, the sunshade stops when it reaches the fully closed position, and the initialization learning movement is completed after releasing the switch.

 During the self-learning process of the sunroof module, the sunroof switch button must be continuously pressed. If the sunroof switch button is released during the self-learning process, the self-learning will fail. ◀

## Wiper Combination Switch

### Wiper Control Combination Switch

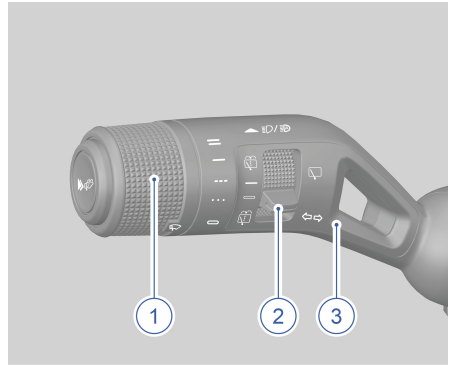

1. Front wiper control switch
2. Rear wiper control switch
3. Light/wiper control lever



- When the front windshield is dry, do not operate the wipers; Otherwise, the wipers will scratch the front windshield, and affect the service life of the wiper blades.
- If there is dust or sandstone on the front windshield, only operate wipers after cleaning the dirt at first; Otherwise, the wipers will scratch the front windshield and affect the service life of glass. ◀

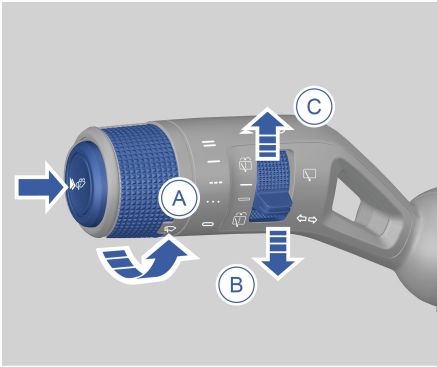

## Operation of Wiper Combination Switch





### Inching Wiping of Front Wipers



Briefly press the  button at the endmost of the light/wiper control lever once, and the front wiper will perform inching wiping operation.



### Turning off the Front Wipers

When you turn the front wiper control switch until the  mark points to  position, the wiper will turn off.



### Automatic Wiping of Front Wipers

Turn the front wiper control switch in A direction until the  mark points to  or  position; the front wiper will perform the automatic wiping operation. The wiping speed is automatically adjusted by the wiper control system as per rainfall.

When the  mark points to  position, the wiper system becomes less sensitive in sensing rain.



When the  mark points to  position, it indicates that the wiper system becomes more sensitive in sensing rain.

### Low-speed Wiping of Front Wipers



Rotate the front wiper control switch in A direction until the  mark points to  —

position, the front wiper will perform the low speed wiping operation.



### High-speed Wiping of Front Wipers



Rotate the front wiper control switch in A direction until the  mark points to  — position, the front wiper will perform the high speed wiping operation.

### Operation of Front Washer

Fully press the  button at the endmost of the light/wiper control lever to the 2nd notch position and hold; the front wiper will wipe continuously while the front washer will keep spraying water. After you release the  button, the front washer will stop spraying water and the front wiper will continue to move for several cycles; then stop.

### Wiping and Washing of Rear Wiper

Push the rear wiper control switch in C direction until the  mark points to  — position; the rear wiper will wipe continuously.

Push the rear wiper control switch in the B direction until the  mark points to  position; the rear wiper will stop wiping.

### Operation of Rear Washer

Push and hold the rear wiper control switch in B or C direction to  position; the rear wiper will wipe while the rear washer sprays water. After you release the rear wiper control switch, the rear washer will stop spraying water and the rear wiper will return to its park position to stop; or wipe continuously after several cycles and then return to its park position to stop.

**THIS PAGE IS INTENTIONALLY LEFT BLANK**

## Light Combination Switch

### Operation of Light Combination Switch

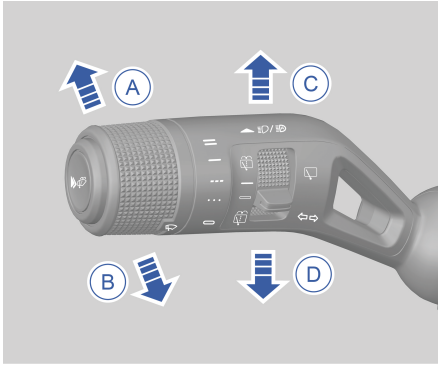

#### Switching between High/Low Beam

To turn on high beam, when the low beam is turned on, push the light/wiper control lever in the A direction to the 1st notch position; the high beam will turn on.

Push the light/wiper control lever in the B direction to either position; the high beam will turn off.

When the intelligent high beam control system is turned on, push the light/wiper control lever in the direction B to the endmost position, and the high beam will turn off.

#### Flashing the High Beam

Push the light/wiper control lever in the B direction to either position and immediately release the lever; the high beam will flash. The high beam can be flashed repeatedly by repeating the same step.

#### Position Lamp

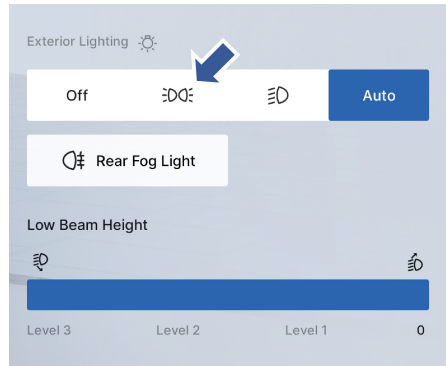

Click the following on the multimedia display: Vehicle Settings → Lights → Exterior Lighting; then click on the position light switch in the interface and a prompt interface will pop up. In the interface, drag the slider to confirm and turn on the position light.

#### Low beam

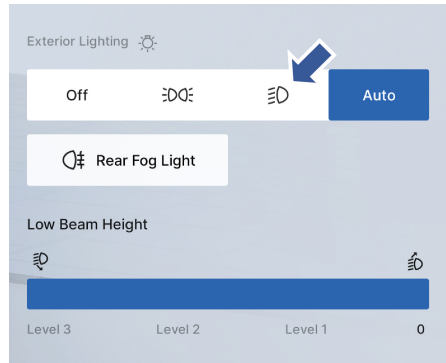

Click the following on the multimedia display: Vehicle Settings → Lights → Exterior Lighting ; then click on the low beam switch in the interface and a prompt interface will pop up. In the interface, drag the slider to confirm and turn on the low beam.

#### Automatic Light

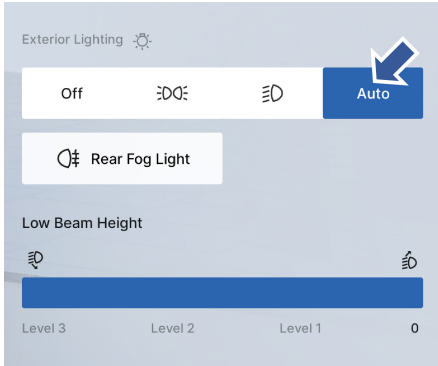

Click the following on the multimedia display: Vehicle Settings → Lights → Exterior Lighting, and then click on the automatic light switch in the interface, and after a prompt pops up, drag the slider to confirm and turn on the automatic light. The automatic light system automatically turns the headlamp on/off based on the intensity of external light, achieving auto control for the position and low beam.

 The system has a manual priority function in automatic light mode. If there is a light signal input, the system will exit the automatic light mode. ◀

## Turn Signal

Move the light/wiper control lever in C or D direction to the endmost position and the right or left turn signal will flash respectively. After the turn is completed, the light/wiper control lever will automatically return to its park position and the turn signal will turn off.

## Lane Changing

Briefly move the light/wiper control lever in C or D direction to a position just enough to activate the right or left turn signal respectively and immediately release the lever. The lever will automatically return to its park

position, and the right or left turn signal will flash 3 times and then turn off.

## Rear Fog Light

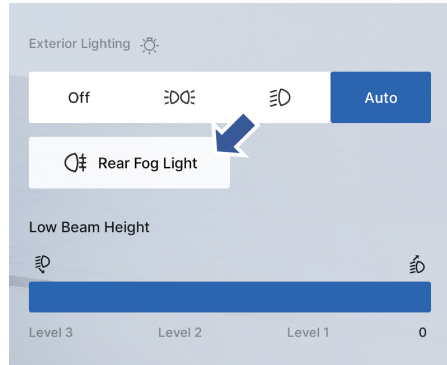

When the low beam is turned on, click the following on the multimedia display: Vehicle Settings → Lights → Exterior Lighting in sequence, and then click the rear fog light button in the interface to turn on the rear fog light.

## Headlamp Height Adjustment

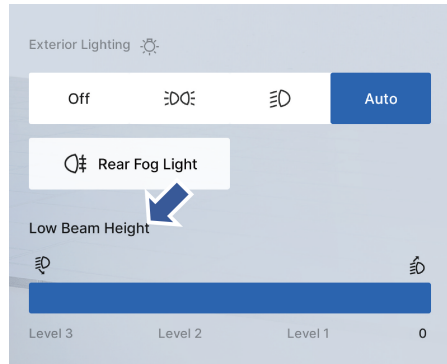

Adjust the height of the headlamp beam according to the number of occupants and the load in the vehicle. Click the following on the multimedia display in sequence: Vehicle Settings → Vehicle Control → Exterior

Lighting and select the height of the headlamp beam in the interface.

### Daytime Running Light

After the vehicle is started, when the low beam is off and in daytime running light mode, the daytime running light will turn on. When the low beam is turned on, the daytime running light will turn off automatically.

 For daytime running light that is built in the headlamp, when the turn signal lamp is activated, the daytime running lamp on the corresponding side will temporarily turn off. ◀

### Follow Me Home



### Turning on the Follow Me Home Function

Click the following on the multimedia display: Vehicle Settings → Lights → Follow Me Home in sequence, and then select your preferable timing under the Follow Me Home setting interface to turn on the Follow Me Home function.

During nighttime, when the vehicle anti-theft is in disabled mode and the Follow Me Home function is enabled in the multimedia display, the Follow Me Home function will

automatically activate after the vehicle is powered off.

### Turning off the Follow Me Home Function

Click the following on the multimedia display in sequence: Vehicle Settings → Lights → Follow Me Home, and then select Off in the Follow Me Home setting interface to turn off the Follow Me Home function.

The Follow Me Home function will turn off temporarily if any of the following conditions is met:

- The vehicle power is not in OFF mod.
- Reaching its time out.
- High beam is turned on.

### Timing of Follow Me Home Function

Click the following on the multimedia display in sequence: Vehicle Settings → Lights → Follow Me Home, and select the activation timer under the Follow Me Home setting interface according to your needs. The Follow Me Home function will perform according to the preselected timer when it is activated; Before time out, if any door (including the tailgate) is opened and all doors are closed, the timer will be reset to the preselected timing time.

## Automatic High Beam Control (AHBC)

The Automatic High Beam Control (AHBC) system can automatically switch between the high beam and the low beams at night. The system uses the front camera to detect the light source information, and automatically switches between the high beam and the low beam according to the situation of the oncoming vehicle, the vehicle ahead and the ambient light source. Generally, this system automatically switches the high beam to low beam when the system detects the headlamps beam of the oncoming vehicle, the taillights of the vehicle ahead or other light sources are detected, in order to avoid the glare of the high beam from affecting other traffic users. When the vehicle done meeting, overtaking or there is no ambient light source around it, the low beam of the vehicle will automatically switch to the high beam.

### Enabling and Activation of AHBC

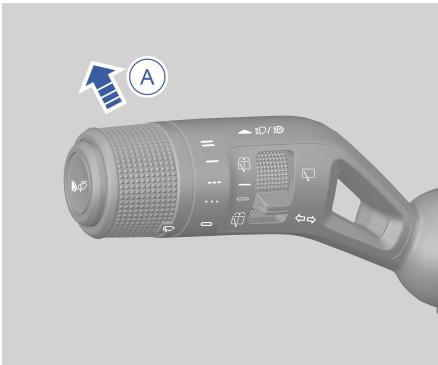

At night, when the external light is set to automatic in the multimedia display, move the light control combination switch in A direction for the first time to turn on the high

beam. Move the light control combination switch in A direction for the second time to activate the Automatic High Beam Control (AHBC) system.

At night, after the front combination lamps automatically turn on, the Automatic High Beam Control (AHBC) system will activate automatically.

After the Automatic High Beam Control (AHBC) system is activated, the Automatic High Beam Control (AHBC) system will turn on the high beam automatically, if all following conditions are met:

1. Vehicle speed  $\geq 40$  km/h;
2. No relevant traffic users or other light sources are detected.

If any following conditions is met, the Automatic High Beam Control (AHBC) system will turn on the low beam automatically:

1. Vehicle speed  $\leq 20$  km/h;
2. Relevant traffic users or other light sources are detected.

 When the Automatic High Beam Control (AHBC) system has turned on the high beam, and the vehicle speed maintains at 20 ~ 40 km/h, the Automatic High Beam Control (AHBC) system keep the high beam on until a light source is detected and the Automatic High Beam Control (AHBC) will turn on the low beam automatically. ◀

### Function Display

When the Automatic High Beam Control (AHBC) system controls the high and low beams of the vehicle headlamp, the Automatic High Beam Control (AHBC) system indicator will illuminate in white.

When the Automatic High Beam Control (AHBC) system fails, the Automatic High

Beam Control (AHBC) system indicator will illuminate in yellow.

 When the driver operates the light combination switch to select and turn on the high beam, the driver's selection prevails. ◀

 The Automatic High Beam Control (AHBC) system is an auxiliary function of the lamp control. It is recommended to use this function when driving on highway, but the system cannot completely substitute the driver's response. The driver should always alert when it is necessary to switch the high/low beam according to the requirements of traffic regulation as well as actual road conditions. ◀

 In the following examples, the Automatic High Beam Control (AHBC) system does not work or only works with some limitations, which may require the driver's response:

- In bad weathers such as rainstorm, heavy snow or heavy fog, in which are not recommended for driving.
- Traffic users (such as pedestrians, cyclists) with poor illumination, railway or waterway traffic near the road, and the road infested with wild animals.
- In the environment with strong reflective views (such as traffic signs on highways).
- When the front windshield is covered with fog, dirt or covered by labels and ornaments. ◀

## Interior Lighting

### Front Interior Reading Lamps



Touch the front interior reading lamp to turn on/off the reading map.

 When driving at night, avoid using the front interior reading lamp. The bright light of the reading lamp may affect the driver's operation and may cause traffic accidents. ◀

### Rear Interior Reading Lamps

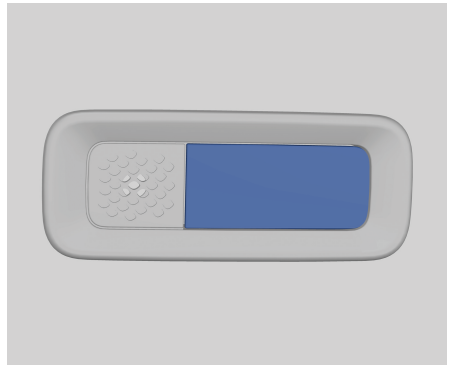

Press the rear interior reading lamp switch of the corresponding side, and the corresponding rear interior reading lamp will turn on or off.

**i** If the rear interior reading lamp switch is in ON position, turn off the rear interior reading lamp switch before leaving the vehicle to avoid the low voltage battery from draining. ◀

### Setting of Reading Lamp

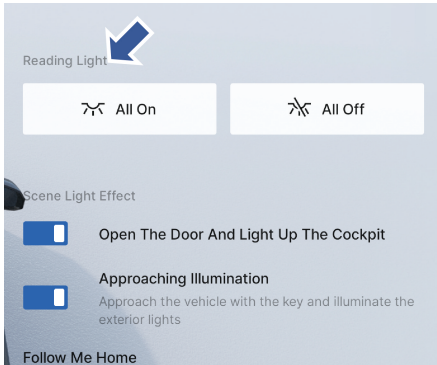

Click the following on the multimedia display in sequence: Vehicle Settings → Lights → Reading Lamps; then enable or disable all reading lamps in the interface.

### Door Control Function of Interior Reading Lamp

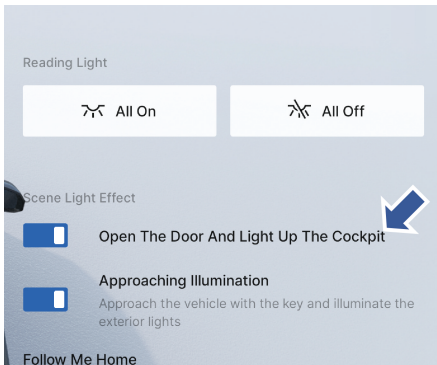

Click the following on the multimedia display in sequence: Vehicle Settings → Lights → Scenes and Light Effect; then enable or

disable the function of Door Control Function in the interface.

After turning on the door control function of Interior Lamp, the interior reading lamp will automatically turn on or off according to the door status.

**i** When using the door control function of interior reading lamp to turn on the left and right interior reading lamps, the corresponding reading lamp can be turned off by pressing the left or right interior reading lamp switch.

### Ambient Light\*

Ambient light are installed on the instrument panel, and on the trim panels of driver door and front passenger door.

### Setting of Ambient Light

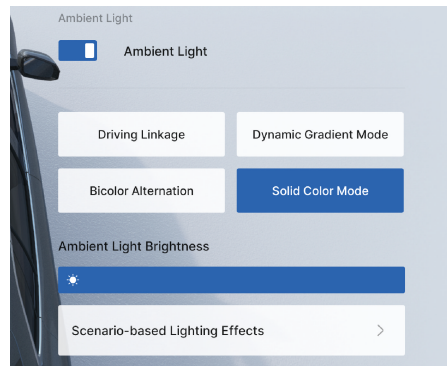

Click the following on the multimedia display in sequence: Vehicle Settings → Lights → Ambient Light, and then select your preferable ambient light in the interface.

## Exterior Lighting

### Approaching Illumination

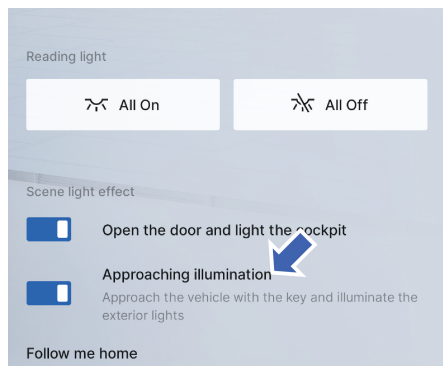

Click the following on the multimedia display in sequence: Vehicle Settings → Lights → Scenes and Light Effect to enable or disable the approaching illumination function in the interface.

When the function is enabled, if you approach the vehicle with a valid intelligent key, the exterior lights will illuminate.

## Hazard Warning Lamp



In case of emergency, if the vehicle needs to be decelerated or stopped in an emergency, press the hazard warning lamp switch. Both front and rear turn signal lamps will flash to warn other traffic users. The hazard warning switch indicator, the left and right turn signal indicators will also flash.

Press the hazard warning lamp switch once again to turn off the hazard warning lamp.

**THIS PAGE IS INTENTIONALLY LEFT BLANK**

## Overview of Meter Instrument

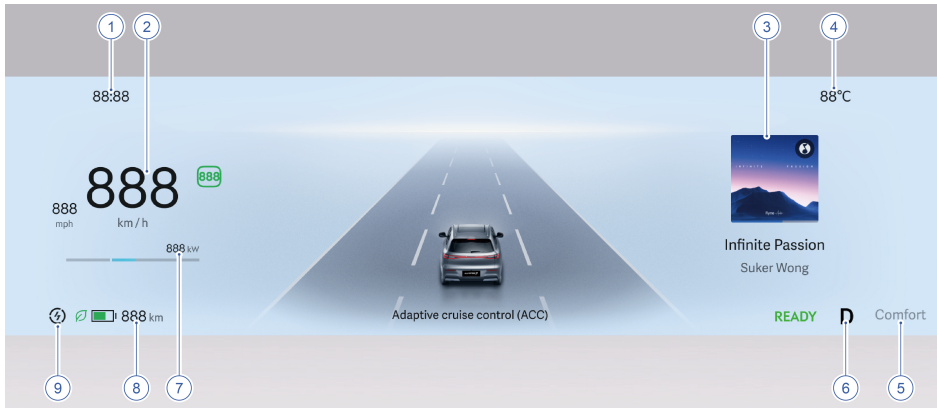

### 1. Clock

Click the following on the multimedia display in sequence: Vehicle Settings → Display → Common Unit → Time, and then set the time format in the interface.

### 2. Speedometer

The speedometer shows the current vehicle speed per hour.

### 3. Information menu

Displays the current playing media audio source, average power consumption, current mileage and vehicle condition information.

Average power consumption: refers to the average power consumption used to drive the vehicle for a certain mileage. Click the following on the multimedia display in sequence: Energy Management → Mileage Statistics → Energy Consumption Curve. After the last 50 km or last 100 km switch is switched, the average power consumption of the instrument will switch and display accordingly.

Power consumption curve: It is drawn based on the power consumption value of driving the vehicle for the last 10 km.

### 4. Outside temperature display area

The outside temperature range is between  $-45^{\circ}\text{C}$  to  $85^{\circ}\text{C}$ .

### 5. Drive modes

Displays the current selected driving mode (ECO, COMFORT, SPORT) by the driver.

### 6. Gear display

Displays the current selected gear (R, N, D, P) by the driver.

### 7. Power meter

Displays the current power output and recovered power of the drive motor.

If the shown power value is positive, this indicates that the drive motor is consuming electrical output power.

If the shown power value is negative, this indicates that the drive motor is recovering energy to charge the power battery.

### 8. Remaining driving mileage of power battery

## Meter Instrument

Displays the remaining driving distance that the vehicle has.

### 9. Energy recovery level

Display the energy recovery level.

 The display mode of meter instrument display can be set on the multimedia display. ◀

 Pictures in the interface of meter instrument are only for reference. All the pictures shall be subject to the actual vehicle. ◀

### Display Screen Settings

 Do not adjust the meter instrument display while driving. ◀

### Steering Wheel Button Adjustment Mode

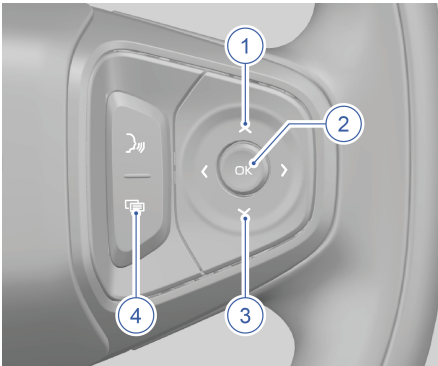

1. Up button: Short press this button to highlight the previous item in the meter instrument menu when the meter instrument menu is opened.
2. Confirm button: Press this button to hide general warning messages or pause the playback of multimedia audio sources.
3. Down button: Short press the button to highlight the next item in the meter

instrument menu when the meter instrument menu is opened.

4. Menu button: Short press this button to open or close the meter instrument menu. When the meter instrument menu is opened, the multi-control of the steering wheel selection button is in the meter instrument control mode. When the meter instrument menu is closed, the multi-control selection buttons of steering wheel is in multimedia control mode.

















### Resetting the Trip Information

































In the trip interface, press and hold the confirm button to reset the trip information.















## Warnings and Indicators

### Introduction of warnings and indicators

Icon	Name	Description
	Left turn signal indicator	Left turn signal is on
	Right turn signal indicator	Right turn signal is on
	Low beam lamp indicator	Low beam lamp is on
		Low beam lamp has a failure
	High beam lamp indicator	High beam lamp is on
		High beam lamp has a failure
	Position lamp indicator	Position lamp is on
		Position lamp has a failure
	Automatic High Beam Control (AHBC) indicator*	Automatic high beam control is on
		Automatic high beam control has a failure
	Rear fog lamp indicator	Rear fog lamp is on
	Headlight height adjustment failure warning	Headlight height adjustment has a failure
		
	Airbag failure warning	The airbag system has a failure
	Brake light failure warning	Brake light has a failure
	Power limit indicator	The vehicle has experienced certain specific failures. Power is limited

Icon	Name	Description
	Powertrain failure warning	Powertrain has a failure
	Evasive Manoeuvre Assist (EMA) failure warning*	Evasive manoeuvre assist function during emergency has failure
	Power battery level indicator	Battery level is insufficient
	Power battery failure warning	Power battery has a failure
	Low-voltage battery charging failure warning	Low voltage battery charging system has a failure
	Charging cable connection indicator	The vehicle is connected to charging cable
	Electric Power Steering System (EPS) status indicator	Steering assist system temporarily lost performance
		Steering assist system has a failure
	Electronic Stability Control System (ESC) status indicator	Always on: Electronic stability control system has a failure Flash: Electronic stability control system is activated
	Electronic Stability Control System (ESC) OFF indicator	Electronic stability control system is off
	Tyre Pressure Monitoring System (TPMS) status indicator	Tyre pressure has a failure
	Brake system status indicator	Brake system has a failure
		Faulty electronic brake force distribution function, or low brake fluid level, or faulty brake fluid level sensor
	Anti-lock Brake System (ABS) failure warning	Anti-lock brake system has a failure
	Electronic Parking Brake System (EPB) status indicator	Always on: Electronic parking brake function is enabled
	Electronic Parking Brake System (EPB) error status indicator	Electronic parking brake function has an error

Icon	Name	Description
	Blind Spot Information System (BLIS) status indicator	The rear side mid-range radar operates normally
		Always on: The rear side mid-range radar is faulty Flickering: The rear side mid-range radar calibration not completed
	Seat belt warning	The seat belt is not fastened, please fasten the seat belt
	Automatic Vehicle Hold (AVH) status indicator	Automatic vehicle hold function is activated
	Warning information indicator	A serious failure has occurred, which may affect the driving performance of the vehicle
		There is a failure warning message/notification, and the corresponding text message appears on the meter instrument display
	Low speed warning indicator	Low speed warning off
		Low speed warning failure
READY	READY indicator lamp	The vehicle is ready, the high-voltage is successfully powered on, and it can be driven normally
	Power battery low temperature indicator	Power battery is in low temperature condition
	Automatic Emergency Brake (AEB) OFF indicator	Automatic emergency brake is off
	Collision Mitigation Support Front (CMSF) fault warning light	Collision Mitigation Support Front (CMSF) fails
	Lane Keep Assist (LKA) system status indicator*	Lane keep assist system is off
		Lane keep assist system has a failure
	Hill Decent Control (HDC) system indicator	Hill decent control system is on standby

Icon	Name	Description
		Hill decent control system has a failure
		Hill decent control system is on
	Cruise system longitudinal control indicator (Cruise Control status and Set Cruise Speed indicator)	The longitudinal control of the cruise system is in an inactive state, indicating the target speed of the cruise control system in standby mode
		The longitudinal control of the cruise system is in an activated state, indicating the target speed of the cruise control system in activated state
		Cruise control system longitudinal control is activated but cannot automatically follow the vehicle to start
	Cruise control system lateral control indicator	Cruise control system lateral control is not activated
		Cruise control system lateral control is activated
		Cruise control system lateral control is suspended
	TSI malfunction indicator*	TSI system fault
	Senseless speed limit indicator*	ISA function does not detect a speed limit or the current road has no speed limit
	LDCA status indicator*	LDCA fault
		LDCA OFF
	Fatigue detection warning*	1st level fatigue detection alarming
		Always on: fatigue detection function failure Flash: 2nd fatigue detection alarming

Icon	Name	Description
		Fatigue monitoring sensors are obscured



- When the power mode is set to ON position or the vehicle is started, some warning lamps will illuminate a few seconds before turn off, indicating that the corresponding system is performing self-check. If any failures are detected, these warning lamps will continuously illuminate or illuminate during driving. Pay attention to it and contact an authorised PROTON e.MAS service outlet for maintenance as soon as possible. Otherwise, severe casualty or property loss may occur.
- The warning lamp will illuminate continuously after starting, or it will illuminate during driving, which indicates that the vehicle may have a serious failure. Please contact an authorised PROTON e.MAS service outlet for inspection and repair as soon as possible. ◀



Black icons in the table are displayed as white or black according to the background in the meter instrument display. ◀

**THIS PAGE IS INTENTIONALLY LEFT BLANK**

## Wired Charging

### Front Charging Slots

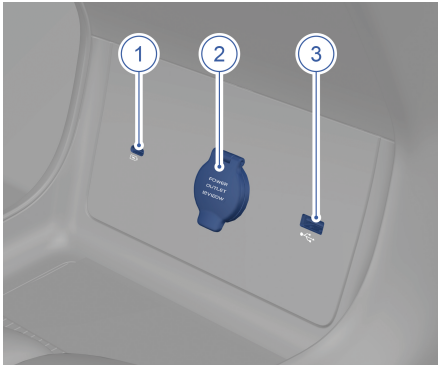

1. Type-C charging slot
2. Power socket
3. USB multimedia slot

Type-C charging slot is used to charge mobile devices, and USB multimedia slot has data transmission and charging functions.

The power socket can be used to connect electrical devices with a maximum limit of 120 W.

The two slots here can be used to charge mobile devices.



- Do not connect the power slot to high-power electrical appliances, otherwise the vehicle fuse may be blown.
- Do not use the power slot in parallel or series with any other power supply.
- Do not modify or repair the vehicle power system without authorisation. ◀

### Rear Charging Slots

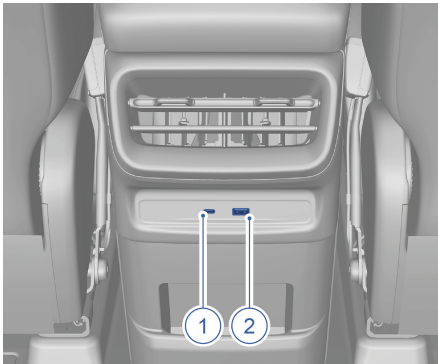

1. Type-C charging slot
2. USB charging slot

## Wireless Charging



The wireless charging pad for mobile phones is located on the front centre console of instrument panel.

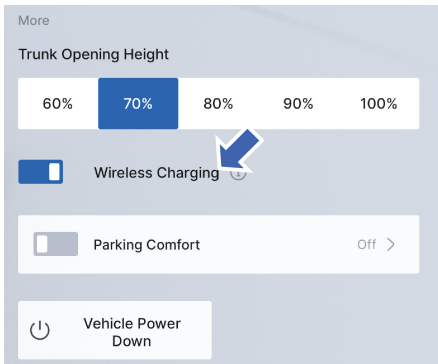

Click the following on the multimedia display in sequence: Vehicle Settings → Vehicle Control → More, and then enable or disable the wireless charging function in the interface. You can also touch and pull down the multimedia screen to access the shortcut panel and click the wireless charging button to enable or disable the wireless charging function in this interface.

To use the wireless charging pad, make sure that the mobile phone is aligned with the center of the wireless charging pad.

Because the wireless charging coil position of each mobile phone is different, it may be necessary to adjust the position of the mobile phone when placing it on the wireless charging pad.



- Do not place heavy objects in the wireless charging pad to avoid damage to the charging area.
- Do not place cards with chips such as NFC cards, bank cards or ID cards together with the mobile phone in the wireless charging area to prevent these cards from being damaged.
- Do not place metal objects between your mobile phone and the wireless charging pad. If a metal object gets stuck between the mobile phone and the wireless charging board, carefully take out the mobile phone and wait for the metal object to cool before removing it. Otherwise, it may cause burning.
- Do not place flammable and explosive items between the mobile phone and the wireless charging pad to avoid safety accidents.
- Do not pour any liquid in the wireless charging pad, otherwise it may cause system failure.
- Do not modify the wireless charging system, otherwise it may damage the vehicle or cause an accident.
- Do not use wireless charging after connecting a wireless charging coil or a mobile phone case with a coil on a mobile phone that does not support wireless charging. Otherwise, the wireless

charging device and mobile phone may be damaged.

- Turn off the wireless charging function when the wireless charging area is used only as storage space.
- When the driver is not in the vehicle, do not place mobile phones to charge in the vehicle to avoid potential safety hazards.
- Wireless charging of mobile phones is only applicable to mobile phones certified by the “Qi” protocol, and it may not be possible to charge properly with non-certified mobile phones.
- Only one phone can be charged at a time.
- Do not place the intelligent key on the wireless charging pad; otherwise, the keyless start function may not work properly when charging the mobile phone.
- To avoid the vehicle from losing power, start the vehicle when using wireless charging. The wireless charging function may stop briefly when starting the vehicle.
- The phone case may cause the phone to not use the wireless charging function properly.
- When the vehicle is driven on bumpy roads, the wireless charging function may pause intermittently or resume charging.
- If the mobile phone cannot be charged normally, make sure that the mobile phone is on the wireless charging pad and there are no other foreign objects stuck in between the mobile phone and the wireless charging pad. Wait for the wireless charging area and the mobile

phone to cool down before trying to charge again.

- Some mobile phones may experience a short interruption during the process of switching from slow charging to fast charging, which will not affect subsequent charging. ◀

## Intelligent Knob

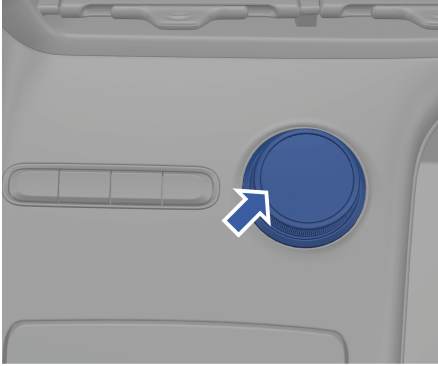

Press and hold the intelligent knob to display the setting menu interface. The setting consists desktop theme, ambient light mode, temperature, and air volume. After select which function for setting, the knob corresponds to the corresponding setting functions.

Press and release to call up the corresponding setting function, and then select the setting function.

 Due to differences in vehicle software versions and vehicle configurations, refer to the actual vehicle for the specific functions that can be realized by the intelligent knob. ◀

## Sun Visor and Vanity Mirror

### Type I



### Type II

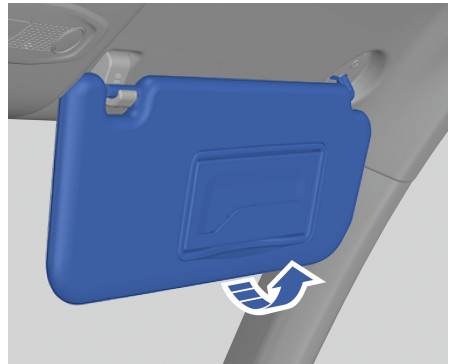

Turn down the sun visor, or pull it out of the bracket and rotate it towards the door to prevent glare.

The vanity mirror is installed in sun visor. Push the mirror cover plate to the left/right to use it. Some models are equipped with vanity lights, which automatically illuminate when the vanity light cover is opened.

## Adjustment of Front Passenger Seat

### Electric Adjustment of Front Passenger Seat\*

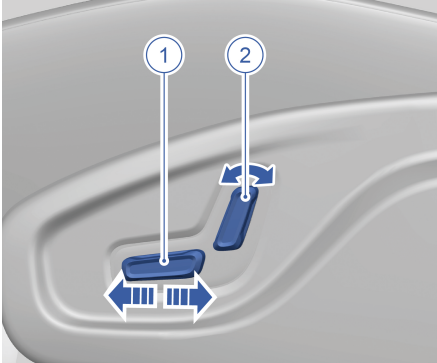

1. Move the switch forward/backward to adjust the front and rear positions of the seat.
2. Move the switch forward/backward to adjust the angle of the seatback.

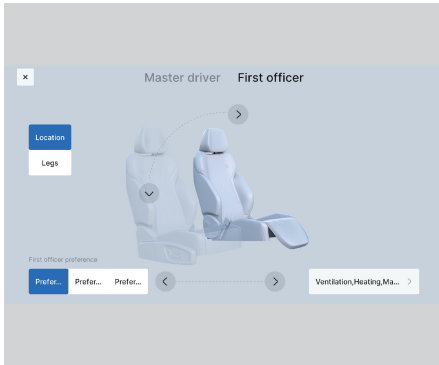

For some models, you can click the following on the multimedia display: Vehicle Settings → Shortcut → Seat Adjustment, and then adjust the front passenger seat in the seat adjustment interface.

## Manual Adjustment of Front Passenger Seat



1. **Seat forward/backward adjustment lever**  
Hold the middle of the front and rear adjustment levers and pull them up. Lean lightly against the seat and slide the seat to the desired position. Release the adjusting lever until the seat slide rail gives a clicking sound and the seat is locked.
2. **Seatback angle adjustment lever**  
Lift the seatback angle adjusting lever to unlock the seatback. Gently press back or slowly leave the seatback to rotate it backwards or forwards to the required position. Release the seatback angle adjustment lever to lock the seatback.

## Front Seat Ventilation\*



1. Click the seat button on the air conditioning interface of the multimedia display to enter the seat adjustment interface;
2. Then, click the corresponding seat ventilation button to select the seat ventilation adjustment button.

 The seat ventilation indicator is shown on the corresponding seat ventilation button itself; indicates the modes of the seat ventilation. OFF, 1st, 2nd, 3rd and AUTO positions indicates that the seat ventilation is in the off, low, middle, high and AUTO position respectively. ◀

## Adjustment of Rear Seat

### Adjustment of Rear Seatback

The rear seatback has two tilt positions.

1. Pull the unlocking lever on the corresponding rear seatback, and tilt the rear seatback one step backward;
2. Pull the unlocking lever again, and tilt the rear seatback one step forward.

 Pull and push the top of rear seatback forward/backward to make sure the seatback is securely locked. Otherwise, the seat belt may not operate normally. ◀

### Folding Rear Seatback

Rear seats features a 40/60 folding function. The trunk space can be enlarged to store large items.

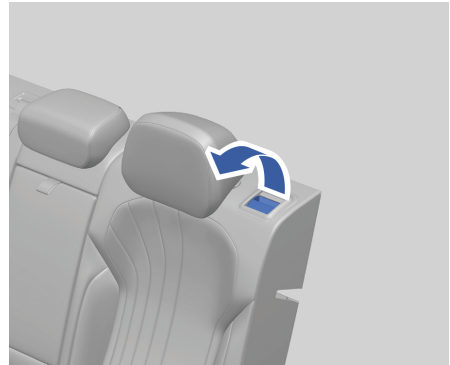

1. Lower the headrest of the rear seat to its lowest position;
2. Pull the unlocking lever of the rear seatback to unlock the rear seatback;
3. Fully fold the rear seatback on the corresponding side.

After the seatback is folded, make sure to leave some spaces between the rear seat headrest and the front seat.

## Unfolding Rear Seatback

Flip the seatback backward and push hard to lock it. Otherwise, the seat belt may not operate normally.

 When driving, passengers are not allowed to sit on the folded seats or in the luggage compartment. The seats should be properly used. When the seatback is returned to the original position, the following precautions shall be considered to prevent injuries upon collision or emergency braking:

- Push forward/backward the top of seatback to ensure the seatback is securely locked. Otherwise, the seat belt may not operate normally.
- Make sure the seat belt is not twisted or stuck under the rear seat, but well positioned for use. ◀

 When the child seat is placed in the rear seat, the child seat and the child seat installation guide cover need to be removed before the rear seatback folding function can be used. ◀

## Adjustment of Front Seat Headrest

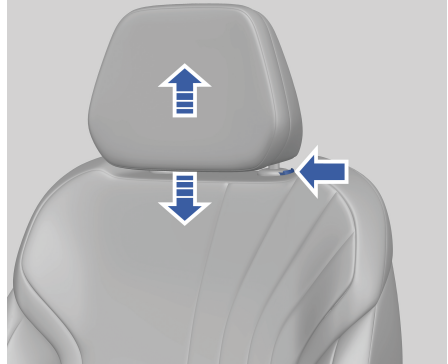

1. Press and hold the adjustment button under the seat headrest.
2. Lift up or press down the headrest to the desired height, and then release the button.
3. Gently press or lift the headrest again until a click is heard, to ensure that the headrest is locked in place.

 Before driving the vehicle, install and adjust the headrest correctly. Make sure the headrest top part is flush with the top of the passenger's head to avoid personal injury or death in the event of an accident. ◀

## Intelligent Headrest Audio\*

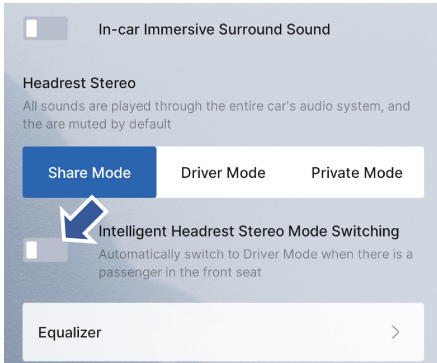

Click the following on the multimedia display in sequence: Vehicle Settings → Sound → Sound Effect → Space Effect to enable the intelligent headrest switching mode function in the interface. When there are people in the front passenger seat, this function will automatically switch the audio setting to driver mode; in which the sound of driver headrest will be turned on. When the navigation, telephone ringtone, and call sound are made, these sounds will only be played through the headrest, and only the driver can hear it clearly.

 The headrest of driver can be adjusted up and down, but cannot be removed. If the audio headrest has a failure, please contact an PROTON e.MAS service outlet. ◀

## Adjustment of Rear Seat Headrest

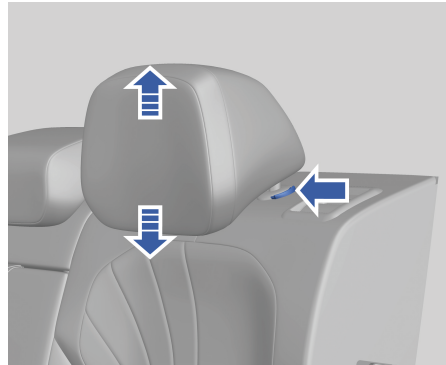

1. Press and hold the headrest adjustment button under the rear seat headrest.
  2. Lift up or push down the headrest to the desired height, and then release the button.
  3. Gently push or lift the headrest again until a click is heard, to ensure that the headrest is locked in place.
-  Press the adjustment button to push in or pull out the headrest. ◀

## Head up Display (HUD)\*

The virtual image display area of the HUD is at the lower part of the front windshield and about 2.3 meters ahead from the driver's view. The driver can turn on/off and set the HUD.

### Setting of Head up Display (HUD)

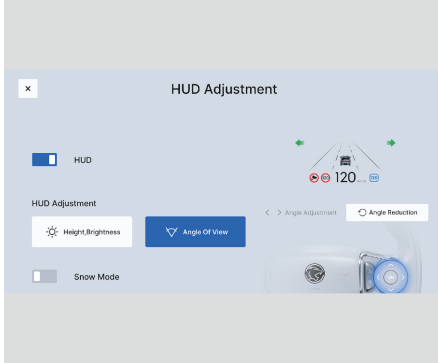

Click the following on the multimedia display in sequence: Vehicle Settings → Vehicle Control → Preferences → HUD, and then start setting the HUD.

### Height and Brightness Adjustment

Click the height and brightness adjustment button in the multimedia interface to turn on the height and brightness adjustment mode.

- Height adjustment: Press the up or down selection button.
- Brightness adjustment: Press the left or right selection button.

After the adjustment has completed, press the confirm button on the right side of the steering wheel to exit the adjustment mode.

 The brightness of the HUD can be intelligently adjusted according to ambient light. ◀

### Angle of View Adjustment

Click the angle of view adjustment button on the multimedia interface to turn on the angle of view adjustment mode.

- Angle of view adjustment: Press the up, down, left and right selection button.

After the adjustment has completed, press the confirm button on the right side of the steering wheel to exit the adjustment mode.

### Snow Mode

Turning on/off snow mode

Click the snow mode button in the multimedia interface to enable or disable the snow mode function.

 You will be able to view the head-up display (HUD) screen clearly when driving in snow by enabling the snow mode function. ◀

 HUD visibility is affected by:

- Sunglasses with polarizing filters or polarizing light may affect the HUD image visibility, that makes the image darker or invisible.
- Under extreme sunlight, the display part of the HUD image may gradually disappear and then recover, which is normal.
- If the light is blocked by foreign objects on the decorative cover of the HUD, it will affect the HUD image display.
- The front windshield is made of a special glass, therefore please go to the PRO-TON e.MAS service outlet for replacement if required.
- Heavy rain or slippery road surface may affect the HUD imaging effect, which is a normal situation. ◀

### HUD Image Information

Within the range of the HUD screen, the display of information such as navigation and intelligent driving system will be displayed in line with the real scene seen by the driver.

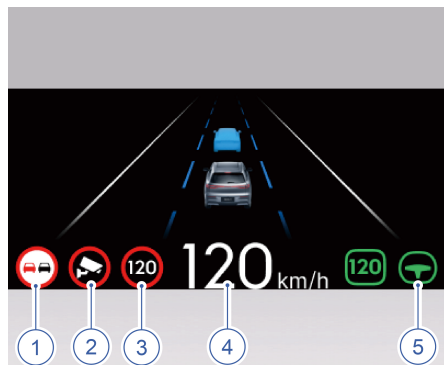

1. Do not overtake
2. Road camera detected
3. Road speed limit information
4. Vehicle speed information
5. Intelligent driving system

## Driving Instructions

Under the following conditions, pay special attention to the underfloor of the vehicle chassis to avoid any scratches:

- When travel on roads with poor conditions.
- When passing road kerbs.
- When travel on steep slopes.



Be extra careful when the vehicle is fully loaded. ◀

## New Vehicle Running-in



Running-in of new vehicle is mainly to improve the surface quality, friction and wear condition of the moving parts. This will also extend the service life of the vehicle and reduce the power consumption. During new vehicle running-in period, observe the following requirements:

- When starting and driving, avoid from fully depressing the accelerator pedal.
- The vehicle should run on flat roads. avoid from driving on roads with muds and sands.
- Avoid idling of the drive motor.
- Avoid accelerating suddenly. ◀

## Eco-driving

Driving habits, storage conditions, charging methods and power battery temperature are factors that affect vehicle range and power battery capacity. Good usage and economic way of driving style can improve the range of the vehicle.

### 1. Stable starting and acceleration

Power consumption is high during the process of starting and accelerating. Avoid sudden stepping on the accelerator pedal when starting or accelerating.

Stable starting and accelerating are helpful to save power.

### 2. Avoid unnecessary braking

Keep a proper following distance from the preceding vehicle and avoid frequent braking; let the vehicle coast to decelerate and apply brake as necessary when approaching a red traffic light. Avoid sudden braking.

### 3. Keep low wind resistance

Driving with open windows at a high speed will increase the wind resistance of the vehicle; therefore will increase of power consumption. Close the windows especially when the vehicle speed is higher than 80 km/h.

### 4. Maintain correct tyre pressure

Check the tyre pressure regularly. Very low tyre pressure will increase the rolling resistance of tyres and result in increase of the power consumption.

### 5. Proper operation of air conditioners

Whether for cooling or heating, the usage of air conditioning will increase the power consumption. Use the air conditioning when necessary. Open the windows for ventilation when driving at low speed. Use the internal circulation mode when using air conditioning for more energy-efficient.

### 6. Reduce the vehicle load

Clear unnecessary luggage on vehicle regularly. Each kilogram of additional load may increase the power consumption

### 7. Plan the driving route properly

Optimize the driving route and avoid traffic jam to save both driving time and power consumption.

- Do not change the size of the tyre at will. Using larger or wider tyre will increase power consumption.

### Driving through Water

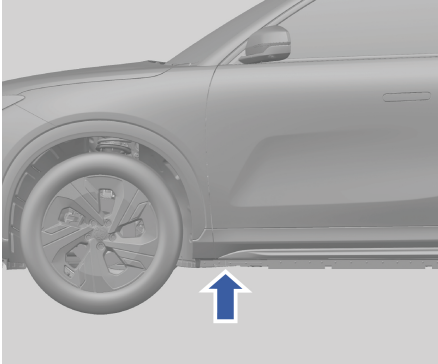

To prevent vehicle being damaged when driving through water (e. g. flooded roads), pay attention to the following precautions:

- Confirm the water depth before driving through water. The water level should not go above the edge of the side member of this vehicle.
- Drive the vehicle at low speed to avoid formation of waves in front of the vehicle which can damage the vehicle components such as the drive motor controller.
- Do not park or reverse this vehicle in water under any circumstances.



- When the vehicle travels on a road with water, mud, etc., the braking effect and distance may be affected. There is a risk of accident!
- Avoid applying sudden emergency brake immediately right after driving through water.

- After driving through water, as soon as possible apply intermittent braking to clean and dry the brakes. Apply brake to dry and clean the brakes only when the traffic conditions permit. Avoid traffic accidents. ◀



- Pay attention to the height of wave formed by other vehicle from the opposite direction may exceed the allowed water level of this vehicle.
- Pits, stones and other obstacles may be hidden in water may cause driving through water more difficult.
- Do not drive through salt water. Salt causes vehicle becomes rusty. Wash all parts in contact with salt water immediately using clean water.
- After driving through the water, it is recommended to go to an authorised PROTON service outlet for a comprehensive inspection of the vehicle. Eliminate any hidden risks and ensure driving safety. ◀

### Parking the Vehicle

- Park the vehicle on a flat, solid and safe road that does not affect the traffic.
- When parking, firstly depress the brake pedal until the vehicle stops slowly and stays still. Then, engage the gear to P position.



- Do not leave children or people with limited mobility unattended in the vehicle. They may accidentally release the parking brake or operate the gear shift lever, causing the vehicle to move and resulting in personal injury or death. ◀

**THIS PAGE IS INTENTIONALLY LEFT BLANK**

## Gear Shift Lever

### Operation of Gear Shift Lever

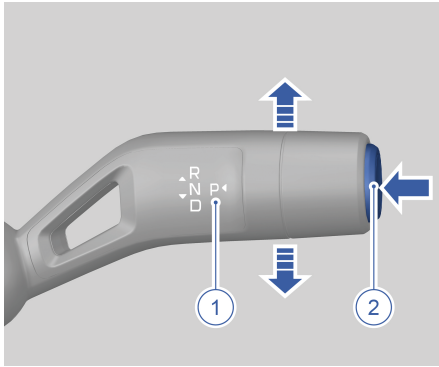

1. Gear Shift Lever
2. Park (P) button

Move the gear shift lever up/down to switch among the following gears: Reverse (R), Neutral (N) and Drive (D). Press the Park (P) button to switch the gear to Park (P) position.

**i** When switching the gear from the position of Drive (D) or Reverse (R) to Neutral (N) position, push and hold the gear shift lever for at least 1 second. ◀

## Drive Mode

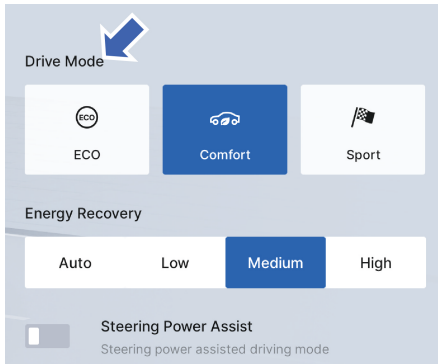

Click the following on the multimedia display in sequence:

Vehicle Settings → Driving → Drive Mode to select the preferable driving mode in the interface.

### ECO mode

In ECO mode, the vehicle consumes less energy and extends the driving range.

### Comfort Mode

In comfort mode, the driver may experience a comfortable driving with this vehicle.

### Sport mode

In sport mode, this vehicle provides the ability for maximum power and quick acceleration.

## Leaving the Vehicle Without Power-off

### Leave the Vehicle Without Power-off Function

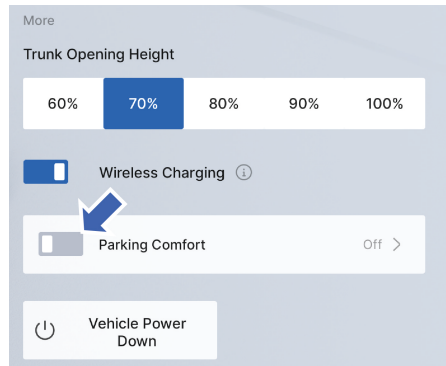

Click the following on the multimedia display in sequence: Vehicle Settings → Vehicle Control → More, and then enable or disable this function in this interface. After this function is enabled, you can continue to operate some equipment in this vehicle. Do not leave children unattended in the vehicle. This function will automatically turn off when the high-voltage battery level is as low as 20%.

▶ When the function to leave the vehicle without power-off is enabled, if you leave this vehicle and short press the lock button/car search button on the intelligent key, this vehicle will be locked but anti-theft system will not be armed and the exterior rearview mirror (door mirror) will not fold. ◀



- When the function to leave the vehicle without power-off is enabled, the driver door status changes from close to open status. At the same time, a warning

message will pop-up on the multimedia display to inform the user that the function to leave the vehicle without power-off will continue to work. Do not leave children unattended in the vehicle.

- When the function to leave the vehicle without power-off is enabled and the high voltage battery level drops to lower than 20%, the function will automatically turn off. At the same time, a warning message will pop-up on the multimedia display to inform the user: the current high voltage battery level is insufficient, and the function has been turned off.
- When the function to leave the vehicle without power-off is enabled and the vehicle power mode status is in ACC position or the hot key setting is used to complete the time adjustment and exit this interface. At the same time, a warning message will pop-up on the multimedia display to inform the user: After the vehicle is locked, the vehicle continues to supply power to ensure that the air conditioning and entertainment system can be used. If the high voltage battery level drops lower than 20%, the vehicle will exit this function and power down. After the user clicks “OK”, the pop-up window closes directly.
- When the high voltage battery level is less than or equal to 20%, the leaving vehicle without power-off switch turns gray. After the user clicks the switch, a pop-up window on the multimedia display screen prompts: The battery level is too low to turn on the leaving vehicle without power-off function.
- When the vehicle power supply is in ON gear, turn the leaving vehicle without powering-off function, and then set the time (time > 0 min). After exiting the time setting interface, a pop-up window prompts on the multimedia display: It has been set up successfully and will start the countdown when the driver leaves the vehicle.
- When the vehicle power supply is OFF, the leaving vehicle without powering-off switch turns gray, and a pop-up window will be displayed if you click on the multimedia display: At this time, the vehicle is not started and this feature cannot be used. ◀

## Energy Recovery

The brake system is also equipped with an energy recovery function.

When the vehicle is coasting or braking in Drive (D) position, the kinetic energy of wheels will be converted into electric energy and charged into the high voltage battery for energy recovery thus extends the driving range.

### Energy Recovery Intensity Modes

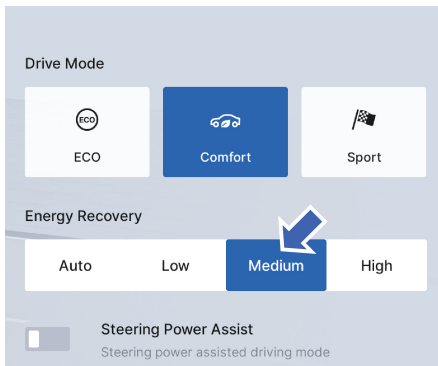

Click the following on the multimedia display in sequence:

Vehicle Settings → Driving → Energy Recovery, and select the energy recovery intensity that you prefer in this interface. The higher the intensity, the higher the energy recovery while coasting.

The braking efficiency produced by the energy recovery may not meet the braking requirement to ensure safe driving. In this case, the driver should apply sufficient braking in time according to the actual traffic situation. ◀



- When the vehicle decelerates, a slight feeling of halt and motor noise may occur. This is normal.
- When the high voltage battery level is full or the high voltage battery temperature is too high or too low, the energy recovery intensity will be automatically reduced to prevent it from being damaged.
- When the motor temperature is too high, the energy recovery intensity will be automatically reduced to prevent it from being damaged. ◀

**THIS PAGE IS INTENTIONALLY LEFT BLANK**

## Anti-lock Braking System (ABS)

The vehicle is equipped with Anti-lock Braking System (ABS) to prevent the wheels from locking when you fully press the brake pedal to achieve maximum braking force. With ABS, the steering control performance of the vehicle under emergency braking can be improved on most road conditions.



The braking distance will be longer on rough or gravelly or snow covered roads than on normal roads. ◀



During braking, you will feel the a continuous “Cluck” sound from the front compartment and a vibration from the brake pedal; This is a normal operation of the anti-lock braking system.



## Electronic Brake-force Distribution (EBD) System

When braking, the electronic brake force distribution system (EBD) system will automatically adjust the brake force distribution ratio of the front and rear axles to improve the braking efficiency, and cooperate with ABS to improve the braking stability, thus ensuring the stability of the vehicle.

## Electronic Stability Control (ESC) System

The Electronic Stability Control (ESC) system is a kind of active safety technology that assists the driver in controlling the vehicle. It corrects the instability of the vehicle body and applies braking force to the wheels or reducing engine torque, and guides the vehicle back to the correct route.

 The ESC system is only an auxiliary system. There are still great dangers when driving on slippery wet roads. Please drive with caution. ◀

ESC will turn on every time when the vehicle is started. To keep control of the vehicle direction, the ESC system should always be activated. If an emergency situation occurs while driving the vehicle, the ESC status indicator will illuminate the meter instrument. This also occurs when the traction control system is activated. You may hear some noises or feel a vibration on the brake pedal, which is normal. Please continue operating the vehicle in your desired direction. If the ESC system fails, the ESC status indicator will stay illuminate and the system will not work properly. At this time, the driving mode should be adjusted.

## Turning Off ESC

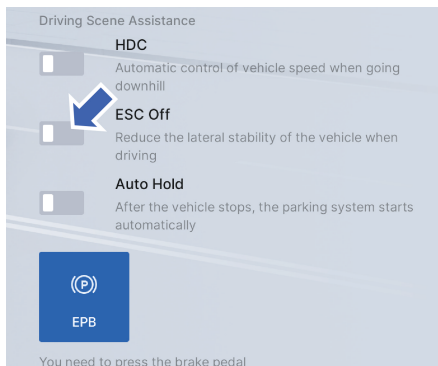

When the vehicle is started, click the following on the multimedia display in sequence: Vehicle Settings → Driving → Driving Scene Assist. Then, click the ESC off button to turn off the ESC system, and the ESC off indicator  on the meter instrument display will illuminate.

When there is insufficient traction force, for example, in the following cases, the ESC system can be disabled:

- When driving the vehicle on deep snow or soft road.
- When the vehicle is trapped (such as in a muddy road) and needed to move the vehicle forward and backward to get out of the trap.

## Turning On ESC

In the multimedia display, click the ESC off button to disable the ESC off function. The ESC will automatically turn on and the ESC off indicator  will turn off.

## Anti Rolling Program (ARP)

The degree of vehicle roll can be calculated by means of signals from the wheel sensors by the anti rolling program to provide additional control of the wheels on the outside of a bend. When the vehicle is about to roll over, the anti rolling program will quickly adjust the braking force distribution between the two wheels, and at the same time reduce the torque output of the drive motor. In this way, the balance of the vehicle can be restored in the shortest possible time, avoiding the vehicle body from rolling over and ensuring the safety of the driver and passengers.

## Brake Assist (BA)

During emergency braking, the brake assist system will increase the driver's braking force and reduce the braking distance.



Brake assist system can only help the driver to increase the braking force. It does not mean that accidents can be avoided. Therefore, you should always keep the distance from the preceding vehicle and drive carefully. ◀

## Traction Control System (TCS)

Traction Control System (TCS) helps the vehicle by preventing loss of traction on the drive wheels. When the system detects that a drive wheel is slipping, it will brake the idle drive wheel to prevent it from idling.

## Hill-start Assist Control (HAC)

When starting on a slope and the driver releases the brake pedal, the Hill-start Assist Control (HAC) can maintain the braking force for about two seconds to prevent the vehicle from rolling back.



The hill-start assist control function can only be activated when the Electronic Stability Control (ESC) system is activated and the electric parking brake (EPB) is fully released. ◀



The hill-start assist control function only maintains the brake pressure shortly when the driver releases the brake pedal. If the accelerator pedal is not pressed or the electric parking brake (EPB) is not engaged, the vehicle may roll back on the slope after about 2 seconds. Therefore, drive carefully when starting on the slope! ◀

## Hill Descent Control (HDC)

HDC can actively brake the vehicle when it is going downhill to ensure that the driver can drive down the steep slope safely at a constant speed.



- HDC only plays an auxiliary role. At any time, the driver should be responsible for the safety of the vehicle and keep an eye on the surrounding traffic.
- When a slope is too large, HDC may not be able to keep the vehicle driving down the steep slope at a constant speed. Then, the vehicle speed can be controlled by pressing the brake pedal. ◀

- HDC cannot be enabled or automatically disabled when the brake temperature is too high.
- Turn on the HDC function via the multi-media display, and the HDC indicator on the instrument cluster display does not light up or turns yellow, indicating that the HDC system cannot be enabled. ◀

## Enabling/Disabling System

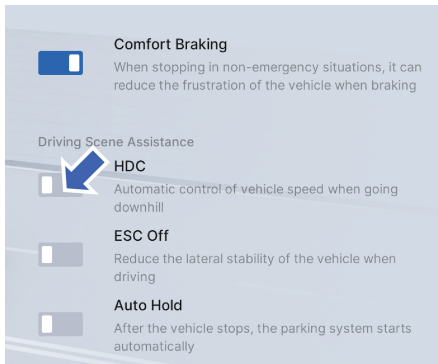

Click Vehicle Settings → Driving → Driving Scene Assist to enable/disable the HDC function in the interface.



- HDC can only be activated when the vehicle speed is less than 35 km/h, and the system will automatically turn off HDC when the vehicle speed is higher than 60 km/h.

## Hazard Warning (HAZ)

When the vehicle brakes in an emergency, the hazard warning lamp automatically starts flashing to warn the other vehicles coming from behind.

## Warning Sound for Pedestrian

When the vehicle is in Drive (D) or Reverse (R) position and the vehicle speed is less than 30 km/h, the warning sound for pedestrian is activated to alert pedestrians to the approaching vehicle.

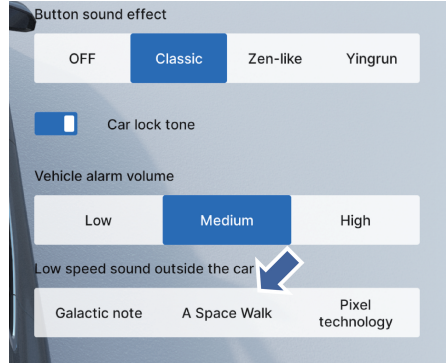

Click the following on the multimedia display in sequence: Vehicle Settings → Sound → Prompt Sound → Vehicle Sound for Pedestrian to select the sound effect in the interface. There are three types of sound effects: Galaxy note, Space walk and Pixel technology.



The system off switch is only available when there are no other road users within a short distance and the surroundings clearly do not require a beep! ◀

## Electric Power Steering (EPS)

The electric power steering system monitors the driving speed and adjusts the power assistance in real time to ensure the portability of low-speed steering and the stability of high-speed steering, and improve the sense of safety.

When it is hard to steer the steering wheel or the Electric Power Steering (EPS) status indicator of the meter instrument lights up, contact an authorised PROTON e. MAS service outlet for maintenance in time.

## Tyre Pressure Monitoring System (TPMS)

The tyre pressure monitoring system (TPMS) monitors the tyre pressure through sensors mounted on each wheel valve.



The TPMS sensors feeds tyre pressure information to the meter instrument and will be shown in real time on the meter instrument display.

- Low tyre pressure warning**  
 When the low tyre pressure warning is activated, the TPMS status indicator lamp in meter instrument will continuously illuminate, the buzzer will beep and the meter instrument display will pop up a warning interface. The low tyre pressure warning will turn off after the tyres are inflated to the correct standard tyre pressure value.
- TPMS sensor failure warning**  
 When the TPMS sensor failure warning is activated, the buzzer will beep and the meter instrument display will pop up a warning interface. Please send the vehicle to an authorised PROTON service outlet for repair.
- TPMS abnormal signal warning**

When TPMS abnormal signal warning is activated, the TPMS status indicator lamp in the meter instrument will blink for 60 seconds and will stay illuminate later, the buzzer will beep and the meter instrument display will pop up a warning interface.

- **Multiple tyre warnings**

When TPMS detects multiple tyre warnings, the meter instrument will pop up all warning interfaces according to sequence of the time when the warning was generated.

- **High temperature tyre warning**

When the high temperature tyre warning is activated, the buzzer will beep and the meter instrument display will pop up a warning interface.

- **Tyre rapid pressure relief warning**

When the tyre rapid pressure relief warning is activated, the buzzer will beep and the meter instrument display will pop up a warning interface.

If the abnormal tyre pressure warning lamp illuminates, this indicates that there one or more tyres has abnormal tyre pressures. At this moment, it is necessary to park the vehicle as soon as possible, inspect the tyre pressures and if any, inflate the tyres to the correct tyre pressure value. Tyre pressure monitoring system of the vehicle can remind you of abnormal tyre pressures but it cannot replace normal tyre maintenance.

### Self-Learning of Tyre Pressure Monitoring System

After the vehicle having a tyre rotation service, the tyre pressure monitoring system needs to be self-learned.

The self-learning methods are as follows:

1. Drive the vehicle at a speed of 30 km/h or more;
2. Driving time should not be less than 20 minutes, and temporary parking should not exceed 10 minutes in total;
3. If the tyre pressure monitoring system still fails to recognize the tyre pressure normally after repeating the above operations, please go to an authorised PROTON e. MAS service outlet for maintenance.



- The recommended tyre pressure value can be viewed from the tyre pressure label on the vehicle.
- Please check the tyre pressure regularly and make sure it is within the specified value range.
- TPMS cannot indicate severe tyre damage that caused by external factors (such as a blowout) in advance, nor can it identify natural, uniform pressure loss over long periods of time in all tyres.
- If the vehicle has just been started, the tyre pressure information displayed on the tyre pressure monitoring interface in the meter instrument are from the previous update. After the vehicle has been driven at a speed of 30 km/h or above for a few minutes, TPMS will gradually update information the pressure and temperature of the four tyres. ◀



- Tyre pressure needs to be adjusted seasonally, inflated in winter and deflated in

summer. Tyre should be inflated when they are cold.

- When driving the vehicle in locations with low and high altitudes, it is normal for the tyre pressure warning to occur. In this case, adjust the tyre pressure according to the tyre pressure warning. ◀



TPMS may work abnormally due to the following reasons:

- Installation of incompatible tyres or modification on wheels.
- Presence of tyre repair fluid or other fluid in the tyre.
- Driving the vehicle with anti-skid chains installed to the tyres.
- Driving in locations with strong radio waves or electrical noise interference such as television stations, airports, etc..
- Installing accessories that cause interference to the vehicle radio receiver or electrical system, etc. ◀

**THIS PAGE IS INTENTIONALLY LEFT BLANK**

## Introduction to The Intelligent Driving System

### Medium-range Radar



1. Rear side medium-range radar
2. Front side medium-range radar\*
3. Front medium-range radar\*

The Intelligent Driving System detects targets through medium-range radar (also known as mid-range radar). During daily use, please note the followings:

- Adverse weather conditions such as rain, snow, fog, etc. can lead to a decrease in the performance of medium-range radar. In such cases, some targets could not be detected, or detected too late.
- Keep the medium-range radar clean. No obstacles and pollutants are allowed at the surface area of the medium-range radar, otherwise it will affect the performance of the intelligent driving system.
- Under special environmental influences, the performance of medium-range radars may deteriorate.
- Do not refit or modify the medium-range radar. The calibration of medium-range radar may be affected, subject to strong vibration and slight impact.

If the surface area of medium-range radar is dirty or covered, the meter instrument display will prompt in text and a sound alarm to

remind the driver to clean the dirt, or drive on the road for a while after cleaning it.



Blindness of medium-range radar is a normal reaction of vehicle under specific road conditions. Make sure the surface of medium-range radar is clean and then, drive the vehicle under normal road conditions for a period of time. The medium-range radar will automatically return to normal. If the radar cannot recover by itself, please go to the authorised PROTON e.MAS service outlet for inspection and maintenance.

Under the following situations, go to an authorised PROTON e.MAS service outlet to have the medium-range radar professionally calibrated:

- The medium-range radar has been removed.
- The toe-in and/or wheel camber have been adjusted during four-wheel alignment.
- After a collision.
- The Intelligent Driving System is degraded or abnormal. ◀

### Front Camera\*



1. Front camera

The Intelligent Driving System (IDS) use front camera to identify lane boundaries and detect targets.

 Keep the front camera clean, and the front camera's visual field of view shall not be blocked by pollutants (such as rain, snow, fog, water vapor, ice and frost, leaves, bird droppings, etc.) or strong light interference. Otherwise, it will affect the performance of the Intelligent Driving System.

The front camera has blind spot and distance recognition limitation, and cannot effectively identify objects that are beyond or at the limit of the front camera's field of view.

- Under bad weather conditions, such as rain, snow, fog and dust, the recognition capability of front camera will be affected, which may degrade the system performance or exit the function. The driver should always monitor the vehicle status and take over the vehicle.
- If a system failure occurs in the front camera, the meter instrument display will prompt in text. Go to an authorised PROTON e.MAS service outlet for maintenance.
- In order to protect the electronic components, the system function will be temporarily unavailable when the front camera is at extremely high temperature. The meter instrument display will prompt in text. When the temperature drops sufficiently, the front camera unit will automatically restart and the system function will return to normal.
- If the front camera is blocked, enters a dark environment (such as entering a tunnel), the light environment suddenly changes, or is interfered by strong light, it may cause the system performance to degrade or exiting from the function. The

driver should always monitor the vehicle status and take over the vehicle.

- Do not modify the front camera. When the front camera is subject to strong vibration and slight impact, the calibration will be affected and may need to be recalibrated. Deformation, damage, replacement and coating of the front windshield may also cause inaccurate recognition. ◀

 Blindness of front camera is a normal reaction under certain conditions.

Without blocking the view of front camera, the driver may avoid dark surrounding and direct sunlight, and then the system will recover itself. If it cannot be recovered, go to an authorised PROTON e.MAS service outlet for maintenance. ◀

 When the vehicle power mode is turned on, the Intelligent Driving System needs to be initialized, and it cannot work normally during initialization process.

◀

## Adaptive Cruise Control System (ACC)

The Adaptive Cruise Control (ACC) system can control the vehicle speed based on the set speed and the set headway (following distance with other vehicle ahead) in the range of 0 ~ 150 km/h.

ACC mainly provides driving assistance for the driver on highways or elevated roads with good road conditions. The driver should keep control of the vehicle at all times.

ACC uses front camera to detect the vehicle ahead and maintain the headway set by the driver through automatic speed adjustment function. The driver can control the vehicle at any time according to driving conditions.

 When the vehicle power mode is turned on, ACC will start self-check, and the system function is not available at this stage. ◀



- ACC is only an assistance system instead of an emergency warning and collision avoidance system, which can not substitute the driver. The driver must always keep control of vehicle and take full driving responsibility for vehicle operation. The driver should drive according to laws and regulations.
- ACC does not work for vehicles or objects crossing carriageway.
- The change of vehicle posture due to excessive load in the luggage area will deteriorate or invalidate the target recognition of ACC system.
- When suddenly accelerating and approaching the vehicle ahead at high

speed (an obvious speed difference with the vehicle ahead), the driver should brake in time.

- When driving on a steep downslope, it may be difficult for this function to keep a proper distance from the vehicle ahead. Under such circumstances, be extra careful and be ready to brake at any time. Never use ACC when the vehicle is under heavy load.
- ACC cannot recognize pedestrians, two-wheeled vehicles (such as bicycle), three-wheeled vehicles (such as tri-cycles), vehicles loaded with irregularly shaped goods or special-shaped vehicles, animals, objects scattered on the road, overturned vehicles, people standing next to or behind the vehicle, etc.
- ACC has a poor recognition rate for stationary or slow-moving vehicles and cannot recognize oncoming vehicles. When using the ACC function, driver needs to always pay attention to the road conditions and vehicle status, and ready to control the vehicle in time.
- When ACC works, if the driver press the accelerator pedal, the vehicle control will be taken over by the driver, and respond to the driver's acceleration desire. The control function of ACC will not work.
- When entering or exiting a curve, the target selection may be delayed or disturbed. ACC may have unexpected braking or late braking.
- In some cases (the speed of preceding vehicle is too low relative to your own vehicle, and the preceding vehicle jumps into the lane closely, etc.), ACC system

does not have enough time to reduce the relative speed. In this case, the driver must respond appropriately.

- If the preceding vehicle suddenly brakes, ACC may fail to respond timely or react too slowly. In this case, the driver will not receive the takeover request. The driver should press the brake pedal for emergency braking.
- At a sharp turn, e.g. a serpentine road, ACC cannot detect the preceding vehicle normally due to the visual field limit of front camera, which may lead to the acceleration of ACC vehicle. The driver is required to respond appropriately based on actual conditions.
- If the distance between the ACC vehicle and the adjacent lane is too small (or the vehicle on the adjacent lane is too close to the lane of ACC vehicle), ACC system may react to that vehicle and brake. ◀

 In following situations, the driver must be more alert:

- When ACC is activated and confirmed to start with the vehicle is stationary, if there are pedestrians, children, animals, two-wheeled vehicles (such as bicycle), three-wheeled vehicles (such as tri-cycles) or obstacles ahead, the ACC cannot detect and identify them, and there is a serious collision risk. The driver must confirm the area ahead of vehicle is safe before activating ACC to control the vehicle when starting to drive.
- In cases where the vehicle speed is high, if the right turn signal lamp is activated when overtaking from the right, ACC will automatically accelerate the vehicle and reduce the distance to the vehicle ahead.

If the vehicle enters the overtaking lane and there is no vehicle ahead, ACC will automatically accelerate to the set cruise speed.

- ACC cannot detect the items loaded or accessories mounted on the target vehicle that protrude from its side, rear end or roof. If the preceding vehicle has the above-mentioned special load or equipment, ACC must be turned off when overtaking such vehicles.
- After the system requires the driver to take over the vehicle, if the vehicle continues to move, the driver must apply the brake pedal to brake.
- Structural modification of vehicle, such as lowering the chassis height, adding any object (sticker, etc) to front windshield or changing the front windshield, may affect the ACC system. ◀

## Function Selection

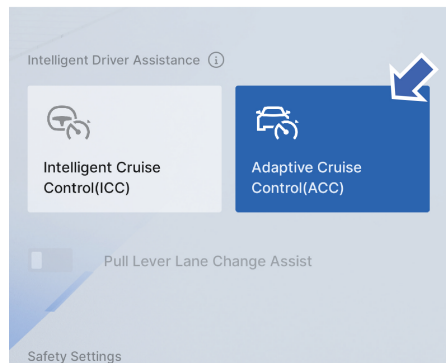

Click the following on the multimedia display screen in sequence:

Vehicle Settings → Auxiliary Driving → Intelligent Driving Assist, and select the Adaptive Cruise Control (ACC) function in this interface.

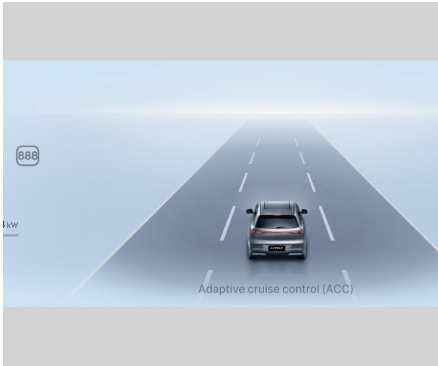

After selecting the ACC function on the multimedia display, ACC can be turned on or off by using the Cruise Control buttons on the left side of steering wheel (via steering wheel control button).

## Steering Wheel Control Button

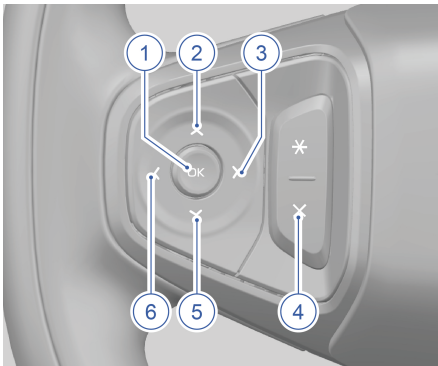

Cruise control buttons for ACC system are on the left side of the steering wheel.

1. OK button  
Press this button briefly to enable (turn on) the ACC system.
2. ACC Speed Increase and Resume button
  - Short press: cruising speed will increase by + 5 km/h.

- Long press: increase the vehicle cruising speed continuously by step of 1 km/h until the button is released.
  - Press this button to resume cruising at the set cruise speed from previously set value before system exit. (only available to vehicle with ACC function).
3. Headway Increase button  
Press this button briefly to increase the cruise following distance (headway) in ACC system (only available to vehicle with ACC function).
  4. Cancel button  
Press this button briefly to cancel ACC activation status (turn off to standby mode) and to exit the ACC system.
  5. ACC Speed Decrease button
    - Short press: cruising speed will decrease by - 5 km/h.
    - Long press: decrease the vehicle cruising speed continuously by step of 1 km/h until the button is released.
  6. Headway Decrease button  
Press this button briefly to decrease the cruise following distance (headway) in ACC system (only available to vehicle with ACC function).

## Function Activation

To activate ACC, the following conditions must be met at least:

- ACC system has been selected in multimedia display screen and enabled via OK button.
- The gear is in Drive (D) position.
- All doors, tailgate (trunk) and hood are closed.

- The vehicle is in motion, and the brake pedal is not applied.
- Brake system has no failure.
- Front camera has no problems, such as high temperature, dirt or failure.
- Electronic Stability Control (ESC) system is active.
- Electric Parking Brake (EPB) is released.
- The driver fastens the seat belt.
- Hill Descent Control (HDC) is turned off.
- Vehicle speed must be greater than 15 km/h, provided that there is no preceding vehicle in front.

### ACC Activation (vehicle is stationary)

When the vehicle is stationary, activate the ACC system as follows:

- Select Adaptive Cruise Control (ACC) in multimedia display screen. Then, press the OK button to turn on (enable) ACC system. The longitudinal control indicator light for the cruise system on the meter instrument display will turn on in grey.
- Press the brake pedal or activate AUTO HOLD function.
- Press the ACC speed increase and resume button to activate ACC. The cruise system longitudinal control indicator on the meter instrument display will turn to green.
- When the brake pedal is released, ACC can continue to keep the vehicle stationary.
- Press the ACC speed increase and resume button again or press the accelerator pedal to make ACC system control the vehicle to start moving.

- ACC will control the vehicle according to the set cruise speed.

### ACC Activation (vehicle is in motion)

When the vehicle is in motion and the Adaptive Cruise Control (ACC) system has been selected in the multimedia display, activate the ACC and set the vehicle speed as follows:

- Press OK button to enable the ACC. The longitudinal control indicator on the meter instrument display will turn on in grey, indicating that ACC is in standby mode.
- Press the ACC speed decrease button to activate ACC and set cruise speed. The cruise system longitudinal control indicator on the meter instrument display will turn to green.

If the vehicle speed is below 30 km/h, the default set cruise speed is 30 km/h. If the vehicle speed is between 30 km/h and 150 km/h, the current vehicle speed will be the set cruise speed.

- ACC will control the vehicle according to the set cruise speed.

### ACC Speed Setting

Press the ACC speed increase and resume button or ACC speed decrease button to increase, reduce and set the desired cruise speed.

## ACC Reminder and Indicator

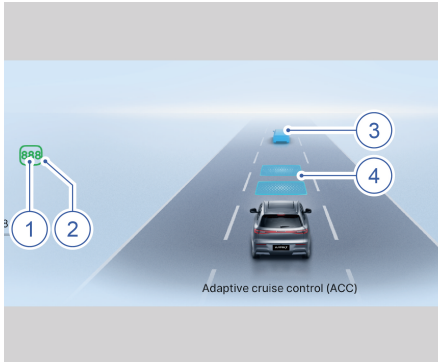

1. **Set Cruise Speed indicator**  
If ACC is not activated (in standby mode), the set cruise speed indicator is grey.  
If ACC is activated, the set cruise speed indicator turns to green.
2. **Cruise System Longitudinal Control indicator**  
If ACC is enabled but not activated (in standby mode), this indicator illuminates in grey.  
If ACC is activated, it turns to green.
3. **Preceding Vehicle Image**  
The preceding vehicle image will turn on in blue when the ACC is activated and following the front vehicle as target.  
If the distance between the vehicle and the preceding vehicle is too close, the preceding vehicle image is yellow.  
If the distance between the two vehicles is too close and the driver's active take-over is required (such as pressing brake pedal), the preceding vehicle image will turn to red.

Once the driver press accelerator pedal to control the vehicle, the preceding vehicle image turns to grey.

4. **Following Distance (Headway)**  
Headway has three levels: near, medium and far. Every time the vehicle is started, the default ACC headway is based on the memorized driver's selection status.

In addition, if ACC or ICC has not been activated during vehicle power mode ON cycle, and the vehicle speed is below 30 km/h, the set cruise speed displayed in the meter instrument is 30 km/h.

When the speed of the vehicle is above 30 km/h, the set cruise speed changes with the speed shown at meter instrument (current vehicle speed).

 In any case, the driver must keep sufficient braking distance from the preceding vehicle and follow relevant requirements of local highway traffic regulations on the minimum distance or the shortest headway distance. It is the driver's responsibility to abide by the law. ◀

## Using the ACC Speed Control

### Accelerating Mode

Acceleration can be performed in two ways:

- **Method 1:** Press the accelerator pedal for active acceleration. In case of active acceleration, the driver takes control of vehicle and the meter instrument shows the active vehicle acceleration speed. After the driver releases the accelerator pedal, ACC continues to control the vehicle to cruise.
- **Method 2:** While the vehicle is running with ACC set cruise speed, briefly press

the ACC speed increase and resume button to slightly accelerate. Short press once will increase the vehicle speed by 5 km/h. Long press the button will increase the vehicle speed continuously by step of 1 km/h until the button is released. The maximum set cruise speed is 150 km/h.

### Overtaking Assist Mode

While ACC controls this vehicle and it follows a preceding vehicle, if you turn on the right turn signal lamp, ACC will accelerate this vehicle before it reaches the overtaking lane to assist the driver until this vehicle completes changing lane.

To enable the overtaking assist mode, the following conditions must be met at least:

- There must be a target vehicle ahead.
- The current vehicle speed exceeds 60 km/h.
- The current lane is dotted.
- The set cruise speed should be high enough for a safe overtaking.
- Turn on the right turn signal lamp.

During overtaking assist mode, unexpected acceleration may occur in the following situations, which requires special attention of the driver. Therefore, during the overtaking assist mode, the driver should prepare for sudden change of conditions and control the vehicle in time.

- The vehicle is approaching the turning exit, and the exit direction is the same as that of usual overtaking.
- Before the vehicle passes through and enters the overtaking lane, the speed of preceding vehicle decreases.
- The speed of other vehicle in the overtaking lane decreases.

During overtaking assist mode, unexpected deceleration may occur in the following situations, which requires special attention of the driver. Therefore, during overtaking assist mode, the driver should prepare for sudden change of conditions and control the vehicle in time.

- The speed of vehicle in the overtaking lane is lower than your vehicle speed.
- The longitudinal distance between the vehicle in the overtaking lane and your own vehicle is close.
- The vehicle in the overtaking lane is large with long body, and parallel to your own vehicle.



During overtaking assist mode, the driver needs to control the lane change on their own. ◀



Please note that this function can be enabled in more situations besides overtaking. For example, when the right turn signal indicator is turned on to change lanes or enter another road, the vehicle will briefly accelerate. ◀

### Stop and Go Mode

During cruise following mode, if the preceding vehicle brakes and stops gradually, ACC will follow the preceding vehicle to stop gradually and keep a safe distance from it.

- Within 5 seconds after following and stopping, if the preceding vehicle resumes moving forward, ACC will follow to resume cruising automatically.
- If the vehicle stops for more than 5 seconds, when the preceding vehicle resumes moving forward, the driver needs to step on the accelerator pedal or press

the ACC speed increase and resume button to resume cruising.

- In ACC stop and go mode, if the driver actively exits the ACC function, the vehicle will not move automatically. If the accelerator pedal is pressed at this time, the vehicle will start to move, and the driver needs to take control of the vehicle and drive safely.

ACC cannot recognize stationary vehicles, and cannot brake against stationary vehicles.



After the vehicle stopped, ACC can still control the vehicle to move, which may result in uncontrolled vehicle movement and may cause traffic accidents, serious injury or fatality. ◀



ACC will have unexpected acceleration in the following situations. Please be highly alert and take active braking:

- When ACC follows another moving vehicle as a target and this target changes from a moving vehicle to a stationary vehicle, ACC will ignore the stationary vehicle and continue cruising at the cruise speed set by the driver.
- When the following preceding vehicle makes a turn at a low speed at an intersection and the ACC following target disappears due to the turning of this preceding vehicle, ACC will accelerate the vehicle based on the set cruise speed. ◀

### Deceleration Mode

While driving in ACC set cruise speed, briefly press the ACC speed decrease button to slightly decelerate the vehicle speed. Every brief press will reduce the vehicle

speed by 5 km/h. Long press the button will reduce the vehicle speed continuously by step of 1 km/h until the button is released. The minimum set cruise speed is 30 km/h.

### Restoring the Set Cruise Speed

If the driver has set the ACC to the required cruise speed and then press brake pedal or press the cancel button, the ACC system will be deactivated. However, the set cruise speed has been stored in ACC system memory. The set cruise speed will continue to be displayed on the meter instrument display. To activate ACC and resume cruising as per the last set cruise speed, press the ACC speed increase and resume button.

### Exiting the ACC

The following methods can deactivate ACC:

- Press the brake pedal to exit the ACC system.
- Press the cancel button on the left side of steering wheel to exit the ACC system.

The ACC system is dependent on the operation of other systems, such as the electronic stability control system (ESC). If any of these systems stop working, ACC will be automatically deactivated.

In case of automatic deactivation, a sound signal is given and the meter instrument display shows a text message. The driver must intervene to match the speed and the distance to the preceding vehicle.

If the front camera has a system failure, in low light, directly under strong light, blocked by objects, or under alternating light conditions, entering or exit tunnel, ACC may be affected and unavailable.

Possible reasons for disabling ACC (including but not limited to):

- Any door, hood or tailgate is opened.
- Driver's seat belt is unfastened
- The wheels losses road holding (traction force).
- The brake system performance is degraded or faulty.
- Parking brake is applied
- Front camera is covered by wet snow or heavy rain.
- Electronic Stability Control (ESC) system is not functioning or turned off.
- Hill Descent Control (HDC) function is turned on.

### Detection Problems

The detection ability of front camera is limited. In some cases, the front camera may fail to detect vehicles or delay the detection of vehicles.

Detection problems may occur in the following situations:

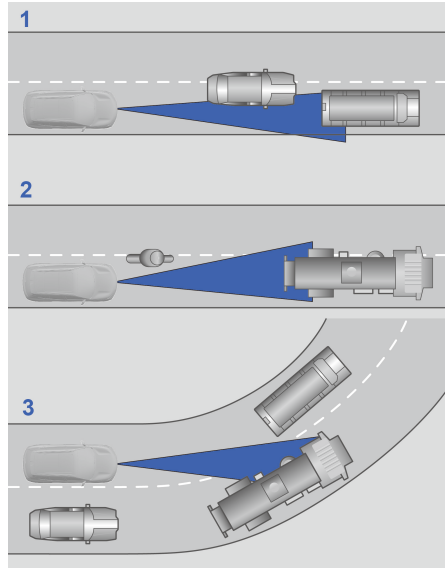

1. Vehicles move slowly along the driver's lane. The system can only detect the vehicle that has fully entered the driver's lane.
2. When the front vehicle is a large truck, the time of detecting the vehicle may be delayed.
3. When the driver enters or exits a curve, detection problems related to the preceding vehicle may occur.

When the vehicle power mode is turned on, the front camera needs initialization, and the preceding vehicle cannot be detected during a certain period of time for initialization.

Under such circumstances (as above), the driver should keep alert. Take emergency measures and temporarily turn off ACC if necessary.

## Intelligent Cruise Control System (ICC)

The Intelligent Cruise Control System (ICC) can simultaneously perform cruise control and direction assist control on the vehicle within the range of 0 ~ 150 km/h. The system can control the speed of the vehicle according to the set speed and the time interval for vehicle following, and perform steering wheel assist control according to the lane lines on the left and right sides. Offset control will be provided when overtaking a truck, and an alarm prompt is given when the driver's move hands away from the steering wheel.

The ICC system mainly provides driving assistance for the driver on highways or elevated roads with good road conditions.

 When the vehicle is powered on, the ICC system will start self-check, and the system function is not available at this stage.

- The ICC function is more suitable for use on expressways and roads with access restriction. At the same time, the driver needs to concentrate on driving, and ensure quick take-over of the vehicle when an emergency occurs.
- The ICC system is only an assistance system instead of an emergency warning and collision avoidance system. The driver should drive according to laws and regulations.
- The ICC system does not work for vehicles or objects crossing carriageway.
- The change of vehicle posture due to excessive load in the luggage area will degrade or invalidate the target recognition of the ICC system.
- If another vehicle cuts into the front of vehicle at low speed, the ICC system may not work. The driver is required to brake in time.
- When suddenly accelerating and approaching the vehicle ahead at high speed (an obvious speed difference with the vehicle ahead), the driver should brake in time.
- When driving on a steep downslope, it may be difficult to keep a proper distance from the vehicle ahead. In these situations, be particularly careful and always be ready to brake. It is prohibited to use the ICC system under heavy load.
- The ICC system cannot recognize pedestrians, tricycles and vehicles loaded with irregularly shaped goods or vehicle variants, also including animals, objects scattered on the road, overturned vehicle, the person standing next to or behind a vehicle.
- The ICC system has a poor recognition rate for stationary or slowly moving vehicles, and cannot recognize oncoming vehicles. During the use of the ICC function, the driver should always pay attention to the road conditions and vehicle status, and take over the vehicle in time.
- When the intelligent cruise assist system is working, it is determined that the driver takes over the steering wheel or wants to change lanes once he/she turns the steering wheel. And, in order to improve the driving experience, the vehicle will be taken over by the driver to respond to the driver's needs. The lateral control

function of the intelligent cruise assist system will not work, and the driver has to perform direction control, as the system will not be able to keep the vehicle in its own lane.

- When the ICC system works, if the driver press the accelerator pedal, the vehicle will be taken over by the driver, and respond to the driver's acceleration desire. The speed control function of the ICC system will not work.
- When entering/exiting a curve, the target selection may be delayed or disturbed. The ICC system may have unexpected braking or late braking.
- If the preceding vehicle suddenly brakes, the ICC system may fail to respond timely or react too slowly. In this case, the driver needs to perform braking actively.
- At a sharp turn, e.g. a serpentine road, the ICC system cannot detect the preceding vehicle normally due to the visual field limit of front camera, which may cause the ICC system to accelerate vehicle. The driver is required to respond appropriately based on actual conditions.



In following situations, the driver must be more alert:

- When the ICC system is activated with the vehicle stationary and confirmed to start, if there are pedestrians, children, animals, two-wheeled vehicles, tricycles or obstacles ahead of vehicle, the ICC system cannot detect and identify them, and there is a serious collision risk. The driver must first confirm that the area in front of the vehicle is safe, and then

activate the ICC system to control the vehicle to start off.

- If the right turn signal lamp is turned on when overtaking from the right, the ICC system will automatically accelerate the vehicle and shorten the distance from the preceding vehicle. If the vehicle enters the overtaking lane and there is no vehicle ahead, the ICC system will automatically accelerate to the set cruise speed.
- The ICC system cannot detect the items loaded or accessories mounted on the target vehicle that protrude from its side, rear end or roof. If the preceding vehicle has the above-mentioned special load or equipment, the ICC system must be turned off when overtaking such vehicles.
- After the system requires the driver to take over the vehicle, if the vehicle continues to move, the driver must apply the brake pedal to brake.
- Structural modification of vehicle, such as lowering the chassis height or changing the front windshield glass, may affect the ICC system. ◀



Under the following road conditions, the performance of the ICC function will degrade or fail to work normally. The driver should keep alert:

- The ICC system is inapplicable to roads with excessively small curve radius.
- The ICC system is inapplicable to roads with invisible lane lines.
- The ICC system is inapplicable to inter-sections of roads.

- The ICC system is inapplicable to roads with vehicle marks (e.g., tyre marks).
- The ICC system is inapplicable to roads of which the lanes increase or decrease.
- The ICC system is inapplicable to roads that the original lane and the new lane have large difference.
- The ICC system may recognize road edges (wall, guardrail, curb, grassland, green belt, asphalt seam connection) as lane lines to work.
- The ICC system is inapplicable to pavements with potholes, bumps, undulations.
- The ICC system cannot recognize road signs and obstacles (such as cone barrels, water hoses, road reflective column), so it is not applicable to construction pavement.
- The ICC system is inapplicable to ultra-wide and ultra-narrow roads.
- The ICC system is inapplicable to zigzag roads.
- The ICC system is inapplicable to bad weather with reduced visibility.
- The ICC system cannot be applied to sudden changes in light, including but not limited to tunnel access/exit. ◀
- At the entrance of highway or trunk road, due to the change of road, the ICC system cannot provide direction assist and will be degraded to cruise control.
- The ICC system cannot work under complex road conditions, e.g.: severely congested road, entering or exit tunnel, complicated traffic changes, crossing, intersections, ramps, lost lane lines, etc. The driver needs to supervise and take control of the function. The ICC system only provides comfort experience when the road conditions are suitable, and the driver should take full responsibility for safe driving. ◀

## Function Selection

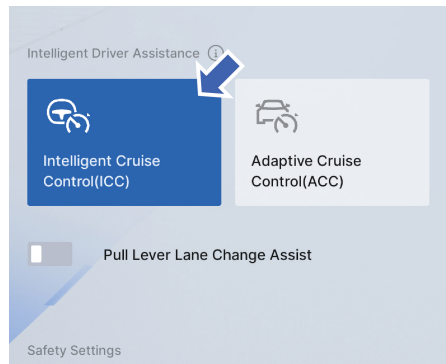

Click the following on the multimedia display in sequence:

Vehicle Settings → Auxiliary Driving → Intelligent Driving Assist, and select the Intelligent Cruise Control (ICC) in this interface.



- When the ICC system follows the preceding vehicle to cross the intersection, your vehicle will move laterally with the preceding vehicle. There is risk of side collision with the adjacent lane. The driver needs to supervise and take control of the function.

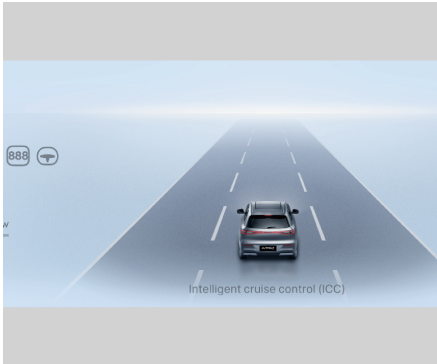

After selecting the ICC function on the multimedia display, ICC can be turned on or off by using the Cruise Control buttons on the left side of steering wheel (via steering wheel control button). The longitudinal and lateral control indicators for cruise control system will illuminate in grey.

### Steering Wheel Control Button

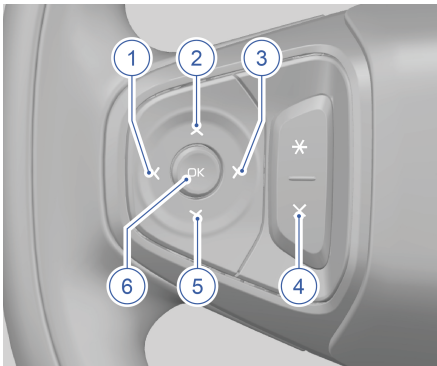

Cruise control buttons for ICC system are on the left side of the steering wheel.

1. OK button  
Press this button briefly to enable (turn on) the ICC system.
2. ICC Speed Increase and Resume button

- Short press: cruising speed will increase by + 5 km/h.
- Long press: increase the vehicle cruising speed continuously by step of 1 km/h until the button is released.
- Press this button to resume cruising at the set cruise speed from previously set value before system exit. (only available to vehicle with ICC function).

3. Headway Increase button  
Press this button briefly to increase the cruise following distance (headway) in ICC system (only available to vehicle with ICC function).
4. Cancel button  
Press this button briefly to cancel ICC activation status (turn off to standby mode) and to exit the ICC system.
5. ICC Speed Decrease button
  - Short press: cruising speed will decrease by - 5 km/h.
  - Long press: decrease the vehicle cruising speed continuously by step of 1 km/h until the button is released.
6. Headway Decrease button  
Press this button briefly to decrease the cruise following distance (headway) in ICC system (only available to vehicle with ICC function).

### Function Activation

To activate ICC, the following conditions must be met at least:

- ICC system has been selected in multimedia display screen and enabled via OK button.
- The gear is in Drive (D) position.

- All doors, tailgate (trunk) and hood are closed.
- The vehicle is in motion, and the brake pedal is not applied.
- Brake system has no failure.
- Front camera has no problems, such as high temperature, dirt or failure.
- Electronic Stability Control (ESC) system is active.
- Electric Parking Brake (EPB) is released.
- The driver fastens the seat belt.
- Hill Descent Control (HDC) is turned off.

### ICC Activation (vehicle is stationary)

When the vehicle is stationary, activate the ICC system as follows:

- Select Intelligent Cruise Control (ICC) in multimedia display screen. Then, press the OK button to turn on (enable) ICC system. The longitudinal and lateral control indicator light for the cruise system on the meter instrument display will turn on in grey.
- Press the brake pedal or activate AUTO HOLD function.
- Press the ICC speed increase and resume button to activate ICC. At this time, the set cruise speed is 30 km/h, the set cruise speed on the meter instrument display will illuminate in grey or green. The cruise system longitudinal control indicator on the meter instrument display will turn to green.
- When the brake pedal is released, ICC can continue to keep the vehicle stationary.
- Press the ICC speed increase and resume button again or press the

accelerator pedal to make ICC system control the vehicle to start moving.

- ICC will control the vehicle according to the set cruise speed.

### ICC Activation (vehicle is in motion)

When the vehicle is in motion and the Intelligent Cruise Control (ICC) system has been selected in the multimedia display, activate the ICC and set the vehicle speed as follows:

- Press OK button to enable the ICC. The longitudinal and lateral control indicator on the meter instrument display will turn on in grey, indicating that ICC is in stand-by mode.
- Press the ICC speed decrease button to activate ICC and set cruise speed. The cruise system longitudinal and lateral control indicator on the meter instrument display will turn to green.  
If the vehicle speed is below 30 km/h, the set cruise speed is 30 km/h. If the vehicle speed is between 30 km/h and 150 km/h, the current vehicle speed will be the set cruise speed.
- ICC will control the vehicle according to the set cruise speed.

### ICC Speed Setting

Press the ICC speed increase and resume button or ICC speed decrease button to set the desired cruise speed.

### ICC Reminder and Indicator

During cruising, as the relative vehicle speed varies, the meter instrument will

display different distance states from the preceding vehicle to your own vehicle to remind the driver.

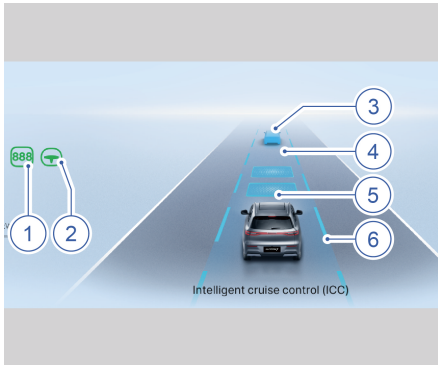

- 1. Set Cruise Speed indicator**  
If ICC is not activated (in standby mode), the set cruise speed indicator is grey.  
If ICC is activated, the set cruise speed indicator turns to green.
- 2. Cruise System Lateral Control indicator**  
Grey when ICC is not activated (system in standby mode).  
Green when ICC performs cruise control and lane keep assist at the same time.  
When ICC only perform cruise control (lateral control LKA not function), this indicator turns black.
- 3. Preceding Vehicle Image**  
The preceding vehicle image is grey when ICC is not activated and will turn on in blue when the ICC is activated and following the front vehicle as target.  
If the distance between the vehicle and the preceding vehicle is too close, the preceding vehicle image is yellow.  
If the distance between the two vehicles is too close and the driver's active

takeover is required (such as pressing brake pedal), the preceding vehicle image will turn to red.

- 4. Following Distance (Headway)**  
Headway can be set to three levels: near, medium and far.  
Every time the vehicle is started, the default headway for ICC system is the far level.
- 5. Lane Shading**  
The indicator is in low light if the ICC is not activated. It is in high light (bright illumination) if ICC is activated.
- 6. Lane line**  
No lane line is displayed when ICC does not detect any lane line. When ICC system is not activated, the lane line is displayed in grey or white  
When the ICC is activated, the lane line is displayed in blue. Red when the lane departure warning is triggered and the vehicle deviates from the lane.  
In addition, if ACC or ICC has not been activated during vehicle power mode ON cycle, and the vehicle speed is below 30 km/h, the set cruise speed displayed in the meter instrument is 30 km/h.  
When the speed of the vehicle is above 30 km/h, the set cruise speed changes with the speed shown at meter instrument (current vehicle speed).

 In any case, the driver must keep sufficient braking distance from the preceding vehicle and follow relevant requirements of local highway traffic regulations on the minimum distance or the shortest headway distance. It is the driver's responsibility to abide by the law. ◀

## Offset Control\*

For vehicles with offset control function, when the vehicle wants to overtake the preceding truck, trailer or other large vehicle (or be overtaken by a large vehicle) with the intelligent cruise control system activated, the system controls the vehicle to actively stay away from the large vehicle in its own lane, and controls the vehicle to return to the middle of its own lane again after overtaking a certain distance. This process does not require any operation by the driver.

 This function can only be automatically turned on when the vehicle speed exceeds 50 km/h, and it is the driver's responsibility to keep his hand on the steering wheel and concentrate on driving. ◀

## Steering Release Warning

When the intelligent cruise control system is activated, it requires you to hold the steering wheel in your hand. If hands are not detected on the steering wheel for a long time, relevant reminder messages will appear on the meter instrument display.

 When both hands are detected, the relevant reminder messages will disappear and the intelligent cruise control system will continue to work. ◀



Please turn steering wheel gently

The function detects that the driver has been in a hands-off state for a certain period of time, and then triggers a first-level steering release warning.



Please take over

If the function detects that the driver has been in the hands-off state for a certain period of time after the first-level steering release warning occurs, the second-level steering release warning will be triggered at this time.



Please take over

After the function detects that the driver is still in hands-off state within a certain period of time after the second-level steering release warning occurs. The intelligent cruise control function will light up the hazard warning light, and exit the function after controlling the vehicle to slow down to 0 in this lane. Then, longitudinal and lateral control are no longer provided until the driver activates the function again.



- Potholes, protrusions, and undulating roads may cause delay or interruption of steering release warning.
- If you gently hold the steering wheel for a long time, you may falsely alarm the steering release warning.
- When the vehicle speed is lower than 10 km/h, there is no steering release warning function. ◀

### Exiting the ICC

The following methods can deactivate the ICC:

- Press the brake pedal to exit the ICC system.

- Press the cancel button on the left side of steering wheel to exit the ICC.

The ICC system is dependent on the operation of other systems, such as the electronic stability control system (ESC). If any of these systems stop working, ICC will be automatically deactivated.

In case of automatic deactivation, a sound signal is given and the meter instrument display shows a text message. The driver must intervene to match the speed and the distance to the preceding vehicle.

Possible reasons for disabling intelligent cruise control (including but not limited to):

- Any door, hood or tailgate is opened.
- Driver's seat belt is unfastened
- The wheels losses road holding (traction force).
- The brake system performance is degraded or faulty.
- Parking brake is applied
- Front camera is covered by wet snow or heavy rain.
- Electronic Stability Control (ESC) system functions or is turned off.
- Hill Descent Control (HDC) function is turned on.

### Detection Problems

The detection ability of front camera is limited. In some cases, the front camera may fail to detect vehicles or delay the detection of vehicles.

Detection problems may occur in the following situations:

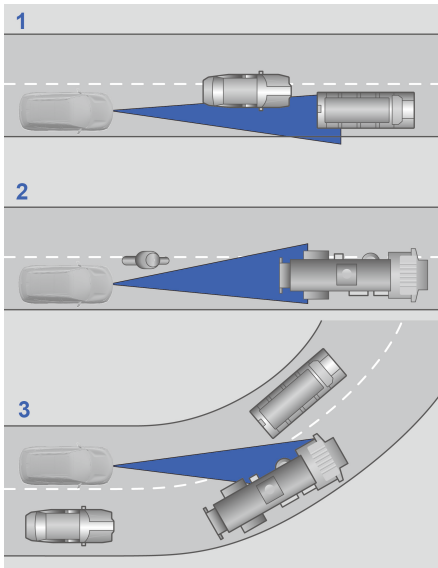

1. Vehicles move slowly along the driver's lane. The system can only detect the vehicle that has fully entered the driver's lane.
2. When the front vehicle is a large truck, the time of detecting the vehicle may be delayed.
3. When the driver enters or exits a curve, detection problems related to the preceding vehicle may occur.

Under such circumstances, the driver should keep alert. Take emergency measures and temporarily turn off ICC if necessary.

- For roads with invisible lane lines.
- For roads with intersections.
- For roads with vehicle marks (e. g., tyre marks).
- For roads that the original lane and the new lane have large difference.
- Potholes, bumps, undulating pavement.

- Construction roads, cone barrels, water hoses, road isolation columns and other road conditions.
- For ultra-wide and ultra-narrow roads.
- For zigzag roads.
- Roads with too small curves (such as ramps, roads around mountains, etc.).
- An intersection or fork road.
- Road with broken and unclear lane lines.
- The driver controls the vehicle actively.

The front camera has limited detection ability. In some cases, the front camera may not be able to accurately judge lane lines, and it's easy to be interfered by the environment.

Lane line detection problems may occur in the following situations:

1. Lane lines are not constructed according to national standards and cannot be recognized.
2. Lane lines are unrecognizable due to low clarity and contrast.
3. The surface of lane lines is covered by dust, water, snow, etc., and cannot be recognized.
4. In rain and snow days, the wheel marks and braking marks of preceding vehicles may be recognized as lane lines.
5. Road boundaries, curbs, etc., may be recognized as lane lines.
6. Continuous lane-line-shaped shadows on road, such as the shadow of railings, may be recognized as lane lines.

### Function Switch

The system will automatically switch the intelligent driving function according to the current road conditions, and it will

downgrade to adaptive cruise function when operating conditions of intelligent cruising assistance function are not met. You can confirm which intelligent driving function is currently enabled via the meter instrument. When any of the following occurs, including but not limited to, it will be downgraded to adaptive cruise control function:

1. The lane markings are confused or the lane markings are incorrectly classified.
2. The lane markings on both sides are not clear or the lane markings are missing.
3. When driving on sharp curves or continuous curves.
4. The driver turns the steering wheel on his own initiative.



When the intelligent cruise assist function is activated, the meter instrument displays a white or gray intelligent cruise assist indicator and a green cruise speed value, indicating that the vehicle can only achieve the function of adaptive cruise control, and cannot achieve the function of keeping the vehicle in its own lane. ◀

## Active Lane Change Assist (ALCA)\*

When the vehicle is driving at a speed of 65~130km/h on a closed road section such as high speed and elevated road, if there is no vehicle in the adjacent lane, the Active Lane Change Assist function can be activated by using the turn signal. After the function is activated, the Active Lane Change Assist function will assist the driver in changing the vehicle to the adjacent lane.



It is the responsibility of driver to determine whether the lane change is safe and appropriate. Therefore, before starting to change lanes, be sure to check the blind spots, lane lines and surrounding roads to confirm that it is safe and appropriate to enter the target lane.

- Do not rely on the Active Lane Change Assist system to determine the appropriate driving route. Pay attention to the road ahead and traffic conditions, pay attention to the surrounding area, check whether there is a warning on the meter instrument, and concentrate on driving. Be sure to take measures at any time.
- Do not use Active Lane Change Assist function on continuous detours with sharp turns, icy or wet roads, or in weather conditions that may obstruct the view of the front camera or medium-range radar (if equipped), such as heavy rain, snow, dense fog, etc.
- When using the Active Lane Change Assist, you must actively observe the surrounding road environment, and then turn the turn signal lever on the corresponding side after confirming that it is safe.

- Even if the vehicle is equipped with Active Lane Change Assist, you need to observe the surrounding environment and keep your hands gripping the steering wheel. When the vehicle automatically changes lanes, so that you can take over the vehicle in time when unexpected situations occur. ◀

## Using Active Lane Change Assist

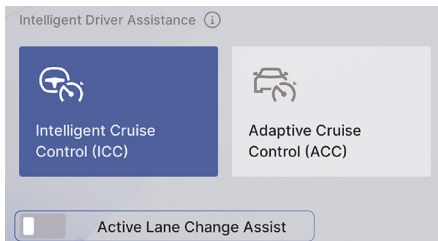

Click the following on the multimedia display in sequence when the Lane Centering Control is turned on:

**Vehicle Settings** → **Driver Assist** → **Intelligent Driver Assistance**, and select to enable or disable the Active Lane Change Assist function in this interface.

After activating the Active Lane Change Assist function, you can use it to change lanes:

1. Ensure safe and proper driving into the target lane by visual inspection.  
When the following conditions are met, the vehicle will be driven into the adjacent lane in the direction indicated by the turn signal by Active Lane Change Assist function:

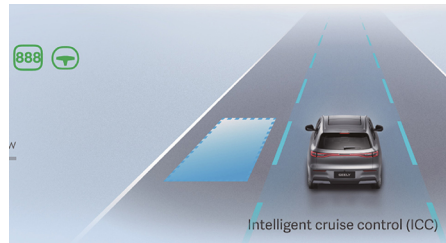

- The driver holds the steering wheel.
  - There are no vehicles or obstacles within the planned trajectory of the target lane.
  - The view of the front camera is unobstructed.
  - No other vehicles detected in the blind spot.
  - The driving speed should be at least 65 km/h.
2. Turn on the corresponding turn signal lamp indicator completely or for a short time.
  3. After completing the lane change, the turn signal lamp indicator turns off automatically or may need to be turned off manually.

During the lane change process, after the overtaking assist is activated, the vehicle will appropriately accelerate to approach the vehicle in front.

A lane change will fail when:

- The driver toggles the turn signal in reverse.
- The driver vigorously turns the steering wheel.
- The driver takes off.
- There are vehicles approaching quickly from behind.
- Beyond the working speed range of the Active Lane Change Assist.



The Active Lane Change Assist can assist the vehicle in driving into one lane at a time. When changing lane again, it is necessary to activate the turn signal again after completing the first lane change. ◀

When using the Active Lane Change Assist function, be sure to pay attention to the driving route ahead and surrounding areas, and pay attention to the lane change process. Be ready to take over the handling of the vehicle at any time. When entering an adjacent lane, the lane line on the meter instrument displays in grey. After entering the new lane, the lane line displays in blue again.

The meter instrument displays a series of warnings when the Active Lane Change Assist does not work at its peak performance, or when it does not work due to insufficient conditions. Therefore, it is important to pay attention to the meter instrument and prepare to handle the vehicle manually when using Active Lane Change Assist function.

### Function Limitation

The detectable range of front camera, front medium-range radar (if equipped) and front side medium-range radar (if equipped) is limited. In some cases, the vehicle in front may not be detected or the detection time may be delayed.

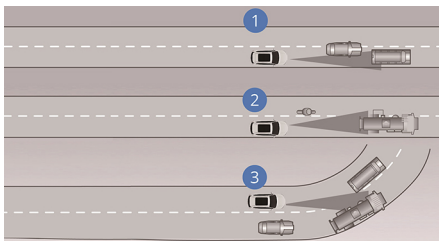

Detection problems may occur in the following situations:

1. Vehicles move slowly along the driver's lane. The system can only detect the vehicle that has fully entered the driver's lane.
2. When the front vehicle is a large truck, the time of detecting the vehicle may be delayed.
3. When the driver enters or exits a curve on the road, detection problems related to the preceding vehicle may occur.

Under such circumstances, the driver should keep alert. Take emergency measures and temporarily shut down the intelligent cruise control system if necessary.

- For roads with no visible lane lines.
- For roads with intersections.
- For roads with vehicle marks (e. g., tyre marks).
- For roads that the original lane and the new lane have large difference.
- Potholes, bumps, undulating pavement.
- Construction roads, cone barrels, water horses, road isolation columns and other road conditions.
- For ultra-wide and ultra-narrow roads.
- For zigzag roads.
- Roads with too small curves (such as ramps, roads around mountains, etc.).
- An intersection or fork road.
- Road with broken and unclear lane lines.
- The driver controls the vehicle actively.

The front camera has limited detection ability. In some cases, the front camera may not be able to accurately judge lane lines, and it's easy to be interfered by the environment.

Lane line detection problems may occur in the following situations:

1. For special lane markings such as triangular or fishbone lane lines, the camera may fail to recognize these markings, which could affect the performance of the function.
  2. Lane lines are not constructed according to national standards and cannot be recognized.
  3. Lane lines are unrecognizable due to low clarity and contrast.
  4. The surface of lane lines is covered by dust, water, snow, etc., and cannot be recognized.
  5. In rain and snow days, the wheel marks and braking marks of preceding vehicles may be recognized as lane lines.
  6. Road boundaries, curbs, etc., may be recognized as lane lines.
  7. Continuous lane-line-shaped shadows on road, such as the shadow of railings, may be recognized as lane lines.
2. The lane markings on both sides are not clear or the lane markings are missing.
  3. When driving on sharp curves or continuous curves.
  4. The driver turns the steering wheel on their own initiative.



When the intelligent cruise assist function is activated, the meter instrument displays a white or grey intelligent cruise assist indicator and a green set cruise speed value, indicating that the vehicle can only achieve the function of adaptive cruise control, and cannot achieve the function of keeping the vehicle in its own lane. ◀

## Function Switch

The system will automatically switch the intelligent driving function according to the current road conditions, and it will downgrade to adaptive cruise function when operating conditions of intelligent cruising assistance function are not met.

You can confirm which intelligent driving function is currently enabled via the meter instrument.

When any of the following occurs, including but not limited to, it will downgraded to adaptive cruise control function:

1. The lane markings are confused or the lane markings are incorrectly classified.

## Lane Keep Assist System (LKA)

The lane keep assist system consists of lane keep assist (LKA), lane departure warning (LDW), lane departure prevention (LDP), and emergency lane keep assist (ELKA) functions.

The lane keep assist system can recognize lane lines, pedestrians, curbs, front/rear incoming vehicles, and calculate the distance from the vehicle to the left/right lane line and front/rear incoming vehicles via front camera and rear side medium-range radar when the vehicle speed is high than 65 km/h.

When the vehicle deviates from the lane or is about to collide with pedestrians, vehicles in the adjacent lane, the system will give a corrective assist force to prevent the lane deviation, mitigate or avoid collision, or remind the driver to keep the vehicle in the lane.

 When the vehicle is powered on, the lane keep assist system will start self-check, and the system function is not available at this stage. ◀

 Make sure the front camera surface is clean. Dirty front camera, bad weather conditions and fading lane lines, may affect the performance of lane keep assist system. ◀

 The lane keep assist system is only suitable for use on expressways and main urban roads, and the driver needs to concentrate on driving the vehicle. When using lane keep assist, you should hold the steering wheel and keep an eye on the road and surrounding traffic.

Do not use this feature on city streets, construction areas, narrow roads, or road sections where cyclists or pedestrians may be present. Do not rely on the lane keep assist system to determine the appropriate driving route. Be sure to take measures at any time and in a timely manner. Failure to follow these instructions can result in serious property damage and personal injuries or even death. ◀

 When the electronic stability control system is turned off (ESC OFF), the lane departure prevention (LDP) and emergency lane keep assist (ELKA) cannot work. ◀

### Function Types in LKA

#### Lane Departure Warning (LDW)

Lane Departure Warning (LDW) warns the driver when the vehicle deviates from the lane unconsciously. Unconscious lane departure includes the already happened lane departure and the imminent lane departure.

#### Lane Departure Prevention (LDP)

As for lane departure prevention (LDP), when the vehicle approaches lane lines and there is a risk of deviation, the system will assist the driver to control the vehicle back to the lane by applying torque to steering wheel.

#### Emergency Lane Keep Assist (ELKA)

Emergency lane keep assist (ELKA) can help the vehicle back to its own lane in the following situations:

- The vehicle is about to rush out of the road or collide with the edge of roads.

- Unintentional deviation from the lane and there may be a collision with the vehicle from opposite direction.
- Unintentional deviation from the lane and there may be a collision with the vehicle from behind (this item is only for vehicles with rear side medium-range radar).
- Unintentional deviation from the lane and there may be a collision with the pedestrians in the adjacent lane.

 ELKA cannot cope with all situations under all kinds of traffic, weather and road conditions. ◀

 This function cannot detect fences, railings or similar obstacles on the roadside. ◀

 ELKA is only enabled when a high risk of collision exists, so do not wait for this function to intervene. ◀

 The driver shall always keep their attention and judgment to ensure vehicle travels safely, keeps a proper distance from other vehicles, and adheres to current traffic laws and regulations. ◀

## Function Selection

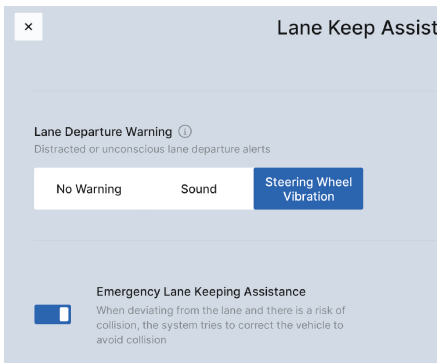

Click on the multimedia display:

Vehicle Settings → Driving Assistance → Safety Settings → Lane Keep Assist, and then choose to turn on or off lane keep assist and lane keep emergency assist in the interface.

**No Warning**, **Sound** and **Steering Wheel Vibration** setting are available for lane departure warning system.

If lane departure warning (LDW) and lane departure prevention (LDP) are enabled, the lane keep assist (LKA) status indicator on the meter instrument display turns off.

## Lane Keep Assist System Display

 The curvature of lane line may be detected inaccurate due to limited front camera performance, e.g., straight road is displayed as curved road. ◀

The lane keep assist system will display the information of system working status on meter instrument.

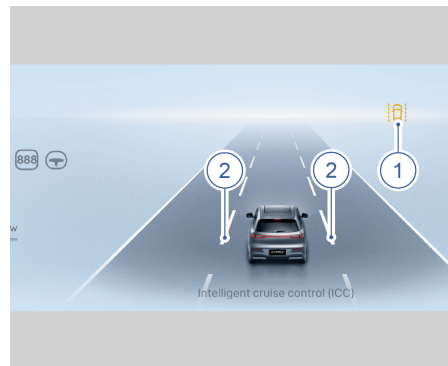

## LKA System Status Indicator (1)

When the lane departure warning or lane departure prevention is activated, the lane keep assist (LKA) system status indicator (1) does not turn on.

When the lane departure prevention system has any fault, the lane keep assist system (LKA) status indicator (1) lights up in yellow. If any of the lane departure warning and lane departure prevention is turned off, the lane keep assist (LKA) system status indicator (1) turn on in yellow and displays **OFF**.

### Lane Line (2)

When the lane keep assist system does not detect the lane lines, the lane lines (2) are not displayed.

When lane keep assist system is not enabled, the lane lines (2) are displayed in gray.

When lane keep assist system is on standby mode, the lane lines (2) on both side are displayed in white.

When the lane departure warning system is activated, the lane lines (2) on the corresponding side are displayed in red.

When lane departure prevention system (LDP) is activated, the lane lines (2) on the corresponding side are displayed in blue.

### Hands-off Warning

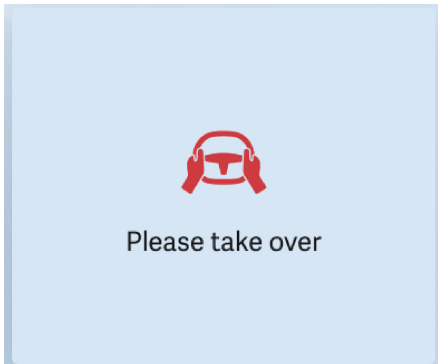

When the lane keep assist system is activated, the driver should always hold the steering wheel with both hands.

If the system does not detect hands on the steering wheel when lane keep assist is activated for the first time, there will be a visual reminder in the instrument cluster, such as turning the lane line blue.

If the lane keep assist is activated again in the next period of time, and the system still does not detect the driver's hands on the steering wheel, the system gives an audible warning and displays relevant reminder on the meter instrument to remind the driver.

 When both hands are detected, the reminder displayed on the meter instrument will disappear. ◀

 Abnormal tire pressure, incorrect four-wheel alignment parameters, inconsistent tires and incorrect tire model, etc., may result in abnormal performance of lane keep assist system. The driver shall use the assist system when the vehicle is in normal condition. ◀

### System Limitation

Under the following road conditions, the LKA performance will degrade or fail to work. The driver should keep alert:

- The lane keep assist system is inapplicable to roads with heavy snow or flood.
- The lane keep assist system is inapplicable to roads with excessively small curve radius.
- The lane keep assist system is inapplicable to roads with invisible lane lines
- The lane keep assist system is inapplicable to intersections of roads.
- The lane keep assist system is inapplicable to roads with vehicle marks (e.g., tire marks).

- The lane keep assist system is inapplicable to roads of which the lanes increase or decrease.
- The lane keep assist system is inapplicable to roads that the original lane and the new lane have large difference.
- The lane keep assist system is inapplicable to pavements with potholes, bumps or undulations.
- The lane keep assist system cannot recognize road signs (cones), so it is not applicable to construction pavement.
- The lane keep assist system is inapplicable to ultra-wide/ultra-narrow roads.
- The lane keep assist system is inapplicable to zigzag pavements.
- The lane keep assist system is inapplicable to bad weather with reduced visibility.
- The field of view of the front camera and the rear side mid-range radar cannot be obstructed by pollutants. Especially, when it's completely covered by water or snow, the lane keep assist system will exit, and the information of system exiting will be displayed at meter instrument.
- The installation of front camera and rear side medium-range radar may be affected by vibration or impact, which will degrade the system performance. At this time, it is necessary to recalibrate the front camera and rear side medium-range radar.

## Collision Mitigation Support Front System (CMSF)

The Collision Mitigation Support Front system (CMSF) or also known as Autonomous Emergency Braking system is a front collision mitigation assist that can warn drivers to pay attention to pedestrians, cyclists and vehicles through warning sound, image display and even active braking.

In case of late braking by driver, excessively small braking force or no braking action at all, the system will act to assist the driver to avoid or mitigate the risk of collision.

CMSF system consists of functions such as Safe Distance Alarm, Forward Collision Warning (FCW), Emergency Brake Assist (EBA) and Automatic Emergency Braking (AEB).

 When the vehicle power mode is turned on, the collision mitigation support front system will start self-check, and the system function is not available at this stage. ◀



- This function is auxiliary and cannot cope with all weather and road conditions.
- The driver is recommended to read all the chapters related to this function in this manual to understand the factors such as function limitation and all the knowledge required before the use of this system.
- The collision mitigation support front system cannot replace the attention and judgment of driver. The driver is always responsible for maintaining proper speed

and distance, and complying with traffic laws and regulations.



- No system can guarantee to operate 100% properly under any circumstances. Therefore, please do not intentionally drive the vehicle toward people or objects to test the CMSF performance. Otherwise, accidents may occur and result in casualties.
- For safety concern, the system cannot work when the driver does not wear the seat belt.
- Usually, CMSF system works in the background and is unnoticeable to the driver. When the system recognizes a danger, it will warn or brake to protect the passengers. Due to system performance limitations, false triggers may occur. The driver must pay close attention to the surrounding at all times. To avoid false triggering, the braking intervention time may be slightly later than the expected time, so the driver needs to respond in time instead of relying on assist driving functions.
- The system will not react to animals, small vehicles (such as tricycles), vehicles with irregular appearance (such as super large vehicles or tractors, trailers, tractors, mud trucks, sanitation trucks, sprinkler trucks), cyclists, oncoming and crossing vehicles.
- For the effective target recognized by the system, due to different vehicles, pedestrians, scenes and road conditions, the system cannot always achieve the same performance.

- The function will not be enabled when the vehicle is driving at a low speed. ◀

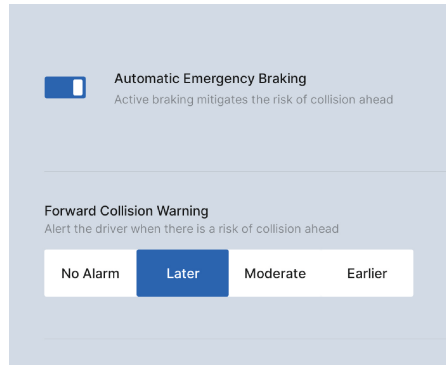
### Function Settings



The collision mitigation support front is a safety system, and the function is enabled by default every vehicle power mode ON cycle.

 If CMSF or AEB has faults, this indicator  on the meter instrument lights up. The driver shall contact an authorized PROTON e.MAS service outlet for maintenance as soon as possible. ◀

Click on the multimedia display in sequence: Vehicle Settings → Assisted Driving → Safety Settings → Pre-collision Assist, and set the alarm timing under the **Forward Collision Warning** setting interface. When no alarm is selected, the alarm timing will automatically reset to **Moderate** after the vehicle power mode is turned ON.

The timing of forward collision warning is divided into four levels: no alarm, later (low), moderate (medium) and earlier (high).

**No Alarm:** It indicates that no alarm is needed.

**Later:** Indicates a short alarm distance and the alarm time is relatively late.

**Moderate:** Indicates a moderate alarm distance and the alarm time is between early and late.

**Earlier:** Indicates a far alarm distance and the alarm time is relatively early.

If the driver thinks the alarm is too frequent, a lower sensitivity can be selected to reduce the total alarms.

## Function Composition

When a danger is judged by the system, the system will assist the driver in the following ways:

- **Safe Distance Alarm**  
The safe distance alarm works in a non-emergency situation. When the vehicle speed reaches 65 km/h or above, it reminds the driver that the following distance is too small, and the driver should adjust the driving behavior and keep a proper distance.
- **Forward Collision Warning (FCW)**  
When the vehicle speed reaches 10 km/h or above, the system considers that there is potential collision risk, and it will prompt the driver of potential collision risk through alarm sound, alarm picture on meter instrument interface and short brake, etc. This function is also known as front collision warning.
- **Emergency Brake Assist (EBA)**  
When the vehicle speed reaches 4 km/h or above, if a danger occurs, but the driver's current braking force is too small, the system will assist the driver to increase braking force to avoid or mitigate the collision.
- **Automatic Emergency Braking (AEB)**

When a danger occurs but the driver fails to perform effective braking, the system will intervene timely by automatic emergency braking to avoid or mitigate collision. Autonomous emergency braking reduces speeds by up to 60 km/h.

## Function Activation

### CMSF Working Speed

The target ahead is a vehicle: When the vehicle speed is 4 km/h~150 km/h, the CMSF system will work. Beyond this range, the CMSF system will not work.

The target ahead is pedestrian and two-wheeled vehicle: When the vehicle speed is 4 km/h~90 km/h, the CMSF system will work. Beyond this range, the CMSF system will not work.

When the forward collision warning function detects a collision risk, it will remind the driver to react in time through sound, pictures on meter instrument and short braking to reduce the collision risk. If the driver applies insufficient braking or no braking, the emergency brake assist or automatic emergency brake will actively intervene to mitigate or avoid collision, and there will be pictures and text prompts on the meter instrument, as well as sound alarm.

### Vehicle Collision Mitigation Assist



The vehicle collision mitigation assist can avoid or mitigate the collision with vehicles. Main application scenario: Front vehicle straight rear-end collision.

When the forward collision warning function detects a collision risk, it will remind the driver to react in time through sound, pictures on meter instrument and short braking to reduce the collision risk.

### Pedestrian Collision Mitigation Assist



The pedestrian collision mitigation assist can avoid or mitigate the collision with pedestrians in front of this vehicle. Main application scenarios: When there are pedestrians crossing the road.

### Cyclist Collision Mitigation Assist



Cyclist collision mitigation assist can avoid or mitigate the collision with cyclists or two-wheeled vehicle. Main application scenarios: When there are cyclists crossing the road/rear-end collision.

### Obstacle Detection

Obstacle targets detected by Collision Mitigation Support Front (CMSF) include cars, regular shaped trucks, buses and other vehicles, as well as pedestrians and two-wheeled vehicle (such as cyclists).

### Vehicles

Collision mitigation support front (CMSF) can detect most vehicles that are stationary or running in the same direction as this vehicle.

Only when the front combination lamps of vehicle turn on normally can the vehicles within a certain range be detected at night.

### Pedestrians

Only when the system detects the unmistakable information of the pedestrian's shape, it can achieve the best working effect. It means that the system can clearly recognize human head, arms, shoulders, thighs, upper

body, lower body, etc., in combination with standard human movement.

The system can detect the pedestrians in contrast to the background, for example, the clothing color of pedestrians is in sharp contrast with the environment color.

If the contrast is low, the pedestrian will be detected late or not detected at all. It means that the warning and braking will be delayed or unachieved.

If a pedestrian is partially blocked, the clothes worn are not easy to be judged as body shape, and if the height is less than 0.8 m, or a large object is carried, he/she can't be detected, which means that braking cannot be achieved.

### Cyclist (Two-wheeled Vehicle)

The cyclist (or two-wheeled rider) must be an adult and the riding vehicle is designed for an adult. Only when the system detects the unmistakable outline information of human body and bicycle (or other two-wheeled vehicle), can it achieve the best working effect. It means that the system can clearly recognize bicycle, two-wheeled vehicle, head, arms, shoulders, thighs, upper body, lower body, etc., in combination with standard human movement.

Partial block, poor background contrast and cyclists (or other two-wheeled vehicle) loaded with large goods cannot be detected by the system, which means that braking cannot be realized.

### Function Limitation

The collision mitigation support front system may be limited in some cases.

### Surroundings



- Strong sunlight, reflection and extreme light contrast may make it difficult for the driver to see visual warning signals, and may also affect the detection of front camera.
- On slippery roads, the braking distance of vehicle is lengthened, which will reduce the anti-collision performance of CMSF.
- If the temperature in passenger compartment is very high, the front camera may be temporarily turned off and the system may not give a warning.
- Under complex driving conditions, the system may apply unnecessary braking. For example, when there is water spraying or splashing at the front of vehicle, vehicle at construction site or underground garage and vehicle drive through railway track or manhole cover. ◀

### Front Camera Vision



- In some cases, the vision of front camera is limited. The system may detect vehicles, pedestrians or cyclists (or two-wheeled vehicle) later than expected, or fail to detect them at all.
- The automatic emergency braking may be degraded and even unavailable when the front camera is blocked or the front camera function is limited.
- In order for a vehicle to be detected at night, its headlamp and tailgate lamp must be turned on and exceptionally bright.

- When the vehicle speed exceeds 90 km/h, the warning and braking intervention for pedestrians and cyclists (two-wheeled vehicle) will be turned off. ◀

### Driver Intervention



- If the driver applies the accelerator pedal or steers to intervene during the automatic emergency braking of vehicle, the system will exit the automatic emergency braking, even if the collision is inevitable.
- While the automatic braking is being triggered, the driver needs a larger force to depress brake pedal.
- When reversing, the system is in suspended temporarily. ◀

## Front Cross Traffic Alert (FCTA)\*

The Front Cross Traffic Alert (FCTA) function monitors the approaching four-wheeled vehicles to the front of this vehicle by using the front side medium range radar. When the vehicle drives forward (exiting the parking space or passing an intersection) and detects the danger of collision at the front of this vehicle with other approaching vehicle, the Front Cross Traffic Alert (FCTA) function gives an alarm and clearly and accurately transmits it to the driver to remind the driver to pay attention to the left and right vehicles.



When the vehicle is powered on, the Front Cross Traffic Alert (FCTA) will start self-check, and the system function is not available at this stage. ◀



This function is auxiliary and cannot cope with all weather and road conditions.

- The driver is recommended to read all the chapters related to this function in this manual to understand the factors such as function limitation and all the knowledge required before the use of this system.
- The Front Cross Traffic Alert (FCTA) cannot replace the attention and judgment of driver. The driver is always responsible for maintaining proper speed and distance, and complying with traffic laws and regulations.
- No system can guarantee to operate 100% properly under any circumstances. Therefore, please do not intentionally drive the vehicle toward people or objects to test the performance of Front Cross

Traffic Alert (FCTA). Otherwise, accidents may occur and result in casualties.

- This system will not react to animals, small vehicles (such as tricycles), vehicles with irregular appearance, pedestrians and oncoming and crossing vehicles.
- When the vehicle is impacted or strongly vibrated, the position of front side medium-range radar may deviate, resulting in degraded system performance. In severe cases, the system will give a fault prompt. Then the driver should contact an authorised PROTON e.MAS service outlet for maintenance as soon as possible.
- For targets effectively recognized by the system, variations in vehicles, pedestrians, environments, and road conditions may cause the system's performance to differ and may prevent it from operating consistently. ◀

 When the steering angle and steering angle rate of vehicle exceed a certain limit, the system function will be limited. ◀

### Working Speed

The working speed range of the driven vehicle is 10~60 km/h, and the speed of the target vehicle is 10~60 km/h.

### Function Activation

The Front Cross Traffic Alert (FCTA) is a safety system, and the function is enabled by default every power on cycle.

### Function Composition

The system will assist the driver in the following ways when it determines that there is

a danger coming from the front left or right side of the vehicle:

When there are vehicles crossing and approaching at an intersection, the system considers that there is a potential risk of collision, and will prompt the driver to pay attention to the left or right vehicle through the alarm sound, alarm image displayed on the meter instrument and head-up display (if equipped) interface.

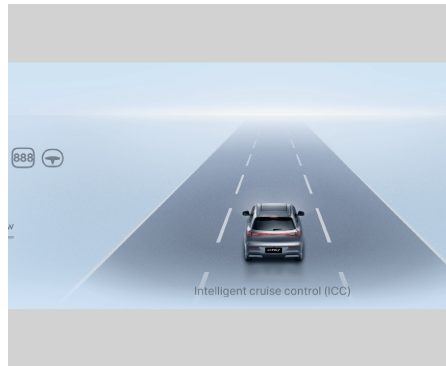

### Obstacle Detection

The Front Cross Traffic Alert (FCTA) can detect such obstacle targets as passenger vehicles, trucks, buses, and other four-wheel vehicles.

### Function Limitation

The Front Cross Traffic Alert (FCTA) may be limited in some cases.

### Front side medium-range radar view

 In some cases, the view of front side medium-range radar is limited. The system may detect vehicles later than expected, or fail to detect them at all, resulting in a late or no warning from the system. ◀

 The Front Cross Traffic Alert (FCTA) performance is not available when the front side middle-range radar function is limited. ◀

 In some scenes such as underground parking lots, due to the mirroring of pillars, etc., interactive systems such as meter instrument will give alarm and graphic prompts on both front sides of vehicle. ◀

 In an oblique parking lot scenario, due to the limited field of view of the front side medium-range radar, the system on one side may give late or no warning. ◀

 If equipped with an electronic trailer module, the system will suppress the FCTA function when the trailer is connected. ◀

## Evasive Manoeuvre Assist (EMA)\*

When the driving speed is in the range of 50~120 km/h, the system detects that the vehicle is about to collide, and the steering force input by the driver is not enough to avoid it, the Evasive Manoeuvre Assist (EMA) will increase the steering force of the vehicle and assist the driver to avoid it.

 When the vehicle is powered on, the Evasive Manoeuvre Assist (EMA) will start self-check, and the system function is not available at this stage. ◀

 This function is auxiliary and cannot cope with all weather and road conditions. ◀

 The Evasive Manoeuvre Assist (EMA) cannot replace the attention and judgment of driver. The driver is always responsible for maintaining proper speed and distance, and complying with traffic laws and regulations. ◀

When the system monitors that the driver has an active overtaking intention, the function will be interrupted or inhibited.

 When the Evasive Manoeuvre Assist (EMA) fails, the fault warning light on the meter instrument lights up. At this time, the driver should contact an authorised PROTON e.MAS service outlet for maintenance as soon as possible. ◀

## Function Activation

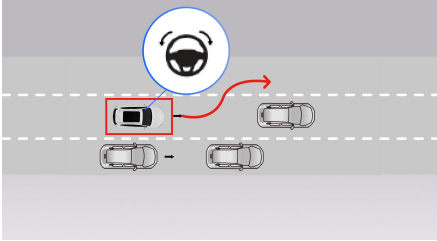

When the system detects that the vehicle is about to collide and the driver operates the steering wheel to avoid collision, the Evasive Manoeuvre Assist (EMA) will increase the steering force of the vehicle and assist the driver in avoidance; when Evasive Manoeuvre Assist (EMA) is activated, the system will automatically return the vehicle to the right after avoiding the obstacle to avoid rushing out of the adjacent lane. When the function is activated, a text prompt will be displayed on the meter instrument to inform the status of this function.

Evasive Manoeuvre Assist (EMA) detects:

- Vehicles
- Pedestrians
- Cyclists

## Function Limitation



When the speed exceeds the range of 50~120 km/h, the function will be turned off.

- The function does not work when a risk of collision in an adjacent lane is detected.
- The function is not available when the driven vehicle crosses the curb.
- The function is not available when a trailer is attached.

- The function is not available when the Electronic Stability Control (ESC) fails, shuts down, or intervenes in the vehicle.
- Strong sunlight, reflection, and extreme light contrast may affect the detection function of the front camera, resulting in the system performance degradation or even inability to work.
- If the temperature inside the vehicle is too high, the front camera and related sensors may be temporarily turned off and the function will not work properly. ◀

## Traffic Sign Identification (TSI) System

Traffic Sign Identification System (TSI) obtains road traffic sign information such as speed limit sign and several prohibitory traffic signs via front camera and map information.

It prompts the driver of current road sign information via the meter instrument in real time. If the vehicle exceeds the current speed limit of the road, the system will give an alarm in time to assist the driver's proper driving.

 It is necessary to update the maps regularly to maintain TSI performance, and the maps can be automatically updated online or known as over the air (OTA) update. ◀

 When the vehicle is power mode is turned on, the traffic sign identification system will start self-check, and the system function is not available at this stage. ◀

 TSI can only serve as a speed limit reminder, and the driver must actively control the vehicle speed. The driver should always be fully responsible for a safe and prudently driving of vehicle and abide by applicable laws and traffic rules.

Despite the Traffic Sign Information Reminder (TSI) function, it is the driver's responsibility to observe the speed limit signs and comply with traffic laws. ◀

## Speed Limit Reminder

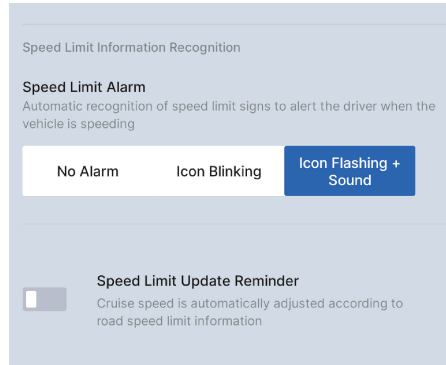



Click the Vehicle Settings → Assisted Driving → Safety Settings → Intelligent Reminder → Speed Limit Information Recognition on the multimedia display in sequence, and then you can set the speed limit alarm mode, vehicle speed limit update, and speed limit deviation setting (if equipped) in this interface.

## Speed Limit Sign Display



When the vehicle reaches the area where the speed limit sign is located, meter instrument will display the speed limit sign, and the display ends after a certain distance.

 If the road speed limit sign is unclear, distorted, inclined, irregular, partially blocked or covered, etc., the recognition of front camera will degrade, resulting in misrecognition or unrecognizable. ◀

 When the map data is not updated or the positioning is inaccurate, the speed limit sign information ahead may not be displayed or the speed limit information may be displayed inaccurately. ◀

 In case of other non-standard signs and positions, it may be identified as speed limit signs, resulting in misrecognition. When vehicle positioning is affected, auxiliary road speed limit signs may be displayed when driving on the main road. ◀

## Overspeed Warning

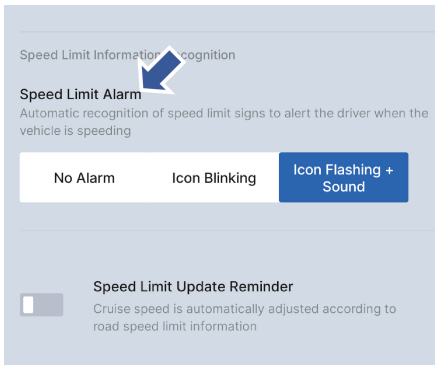

On the multimedia display, click in sequence:

Vehicle Settings → Assisted Driving → Safety Settings → Intelligent Reminder → Speed Limit Information Recognition, then select the alarm mode in the Speed Limit Alarm interface.

**No Alarm:** The meter instrument only displays the speed limit sign.

**Icon Blinking:** The speed limit sign in the meter instrument flashes.

**Icon Flashing + Sound:** The speed limit sign in the meter instrument flashes accompanied by an audible reminder.

## Second Speed Limit Alarm

When the vehicle speed exceeds the speed limit value plus the deviation value recognized by the system, an alarm is triggered, and the system gives the first alarm.

When the vehicle speed is less than the speed limit plus deviation value recognized by the system, the first alarm is canceled.

When the vehicle speed drops to the alarm trigger value minus 5 km/h or more, and the vehicle speed exceeds the alarm trigger value again, the system will give a second alarm. Otherwise, the alarm will not be triggered, until the speed limit value is updated.

 The speed limit alarm function only serves as a speed limit reminder. The driver shall actively control the vehicle speed. ◀

## Speed Limit Update Reminder

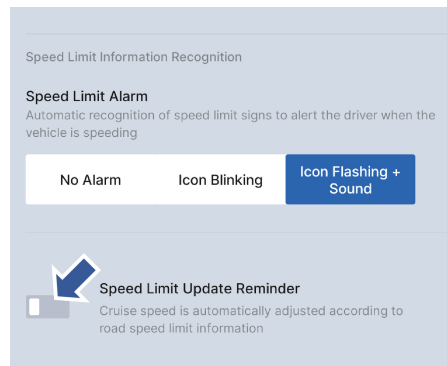

On the multimedia display, click in sequence:

Vehicle Settings → Assisted Driving → Safety Settings → Intelligent Reminder → Speed Limit Information Recognition, then select to enable or disable the speed limit update reminder in this interface.

When enabled, the cruise speed will be automatically adjusted according to the detected road speed limit information.

### Speed Limit Deviation Setting\*

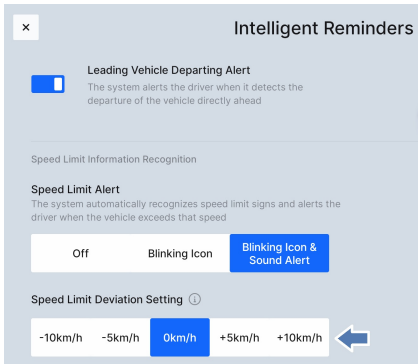

On the multimedia display screen, click in sequence:

Vehicle Settings → Assisted Driving → Safety Settings → Intelligent Reminder → Speed Limit Information Recognition, then select the required deviation value in the speed limit deviation setting interface as shown above.

An alarm is given when the vehicle speed exceeds the speed limit plus the its deviation setting.

## Road Traffic Sign Recognition



Currently, this function is capable of recognizing and displaying a limited set of traffic signs on the meter instrument display to assist the driver.

The recognisable signs include, but are not limited to: No Overtaking, End of No Overtaking, Children Crossing, and Road Construction signs.



- This function is influenced by factors such as the field of view of the front camera, the relative positioning between the camera and the traffic sign, and vehicle speed. As a result, traffic signs may be incorrectly identified or not detected. Therefore, drivers should not rely solely on this function to determine appropriate driving behavior.
- If a traffic sign or speed limit sign is unclear, distorted, tilted, irregular in shape, partially obstructed, or covered, the front camera's recognition performance may be degraded, potentially resulting in misidentification or failure to detect the sign.

- When vehicle positioning accuracy is affected (e.g. by GPS signal loss or road complexity), auxiliary road traffic signs may be erroneously displayed while driving on the main road.
- The presence of non-standard or unusually positioned signs may lead to them being incorrectly identified as valid traffic signs, resulting in false recognition. ◀

 The prohibition information for No Left Turn is displayed to the driver only when the left turn signal is activated. Similarly, No Right Turn and No U-turn prohibition information is displayed only when the right turn signal is activated. ◀

## Rear Side Radar Assist System (RSRS)

The system detects the rear side of the vehicle based on the rear side medium-range radar on both sides of rear bumper, to realize the Rear Collision Warning (RCW), Rear Cross Traffic Alert (RCTA), Lane Change Assist (LCA) that includes blind spot monitoring function and Door Opening Warning (DOW).

 When the vehicle is powered on, the rear side radar assist system will start self-check, and the system function is not available at this stage.

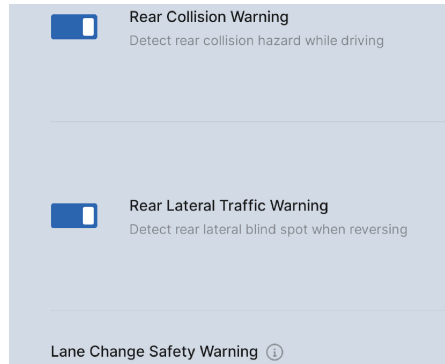

On the multimedia display, click in sequence:

Vehicle Settings → Assisted Driving → Safety Settings → Pre-collision Assist and enable or disable the functions as demand in this interface. The state of all function switches remains as the previous setting.

The system will prompt the driver of driving safety via the on/flashing of blind spot monitoring indicator on the exterior rearview mirror, meter instrument prompt, sound alarm, flashing of hazard warning lamp, etc.

When the vehicle is powered on, the blind spot monitoring status indicator on the meter instrument display lights up in green, and the system works normally. There is a malfunction when the blind spot monitoring status indicator lights up in red.



- Please keep the both sides of rear bumper surface clean;
- This system is only for driver assist, and it cannot replace the driver's safe driving.
- Do not dismantle or exchange the rear side medium-range radar.

### Lane Change Alert (LCA)

The lane change alert function covers the blind spot area and the rear area with fast approaching vehicles, to assist and alert the driver against blind spots and rear vehicles when driving, especially when turning or changing lanes. The lane change safety warning function works within the speed range of 15 ~ 150 km/h.

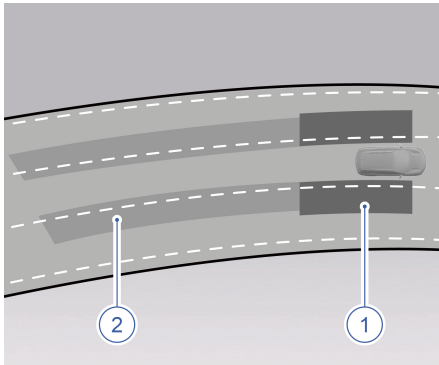

1. Blind spot area
2. Area with fast approaching vehicles



When the alarm condition is met, the blind spot monitoring indicator light on the exterior rearview mirror lights up or flashes. If the indicator and warning sound function are turned on in advance in the multimedia display, the system will also give a warning sound.



In some cases, it's difficult for the lane change warning function to assist the driver. Possible situations include:

- Bad weather such as rain or snow.
- For smaller targets (pedestrians, bicycles, etc.).
- For stationary targets (vehicles, pedestrians, etc.).

- When driving on sharp bends and slopes.

## Rear Collision Warning (RCW)

The rear collision warning function can monitor the targets behind the vehicle. When a vehicle is detected quickly approaching behind, the hazard warning lamp turns on to remind the rear vehicle to slow down or keep a safe distance.

When the vehicle is stationary and the gear lever is in the neutral (N) or park (P) or drive (D) position, if a rear-end collision risk is detected, system may trigger the brake to reduce the risk of slipping forward for the vehicle involved in rear-end collision and avoid secondary collision between the own vehicle and the vehicle ahead. The RCW function will not trigger only when vehicle gear lever is in reverse (R) position.



The rear collision warning function works in Neutral (N)/Park (P)/Drive (D), and the vehicle does not slip backwards. The detection of the rear approaching targets includes the following targets, etc:

- Four-wheeled vehicle
- Two-wheeled vehicle



Click the following on the multimedia display in sequence:

Vehicle Settings → Assisted Driving → Safety Settings → Pre-collision Assist, and then select to enable or disable the rear collision warning in this interface.

In some cases, it's difficult for the rear collision warning function to provide help. Possible situations include:

- The rear vehicle changes lane at the last minute.
- Too late to detect a vehicle coming from behind in scenes such as sharp bends and ramps.
- The relative speed between rear vehicle and the own vehicle exceeds 72 km/h or the relative speed is less than 10 km/h.

 The rear collision warning function cannot avoid collision. The driver should pay attention to the warning and take actions accordingly for safe drive.

## Door Opening Warning (DOW)

When the vehicle is stationary or at low speed, the rear side middle-range radar detects the approaching movable targets at the rear side. When a potential collision risk exists to open the door, the blind spot

monitoring indicator on the exterior rearview mirror lights up or flashes and gives a warning sound to remind the driver of the risk to open the door.

The door opening warning function mainly detects the following targets:

- Four-wheeled vehicle
- Two-wheeled vehicle
- Running pedestrians



Click the following on the multimedia display in sequence:

Vehicle Settings → Assisted Driving → Safety Settings → Pre-collision Assist, and then select to enable or disable the door opening warning in this interface.

In some cases, it's difficult for the door opening warning function to assist the driver.

Possible situations include:

- Bad weather such as rain or snow.
- The relative speed between the rear vehicle and the own vehicle is too high or too low.
- The rear vehicle approaches after changing lanes from other lanes.
- In sharp turns, ramps and other scenes.
- For smaller targets (pedestrians, bicycles, etc).



After the vehicle power mode is turned OFF for 3 minutes or the vehicle is locked and powered off, the door opening warning function stops working.

### Rear Cross Traffic Alert (RCTA)

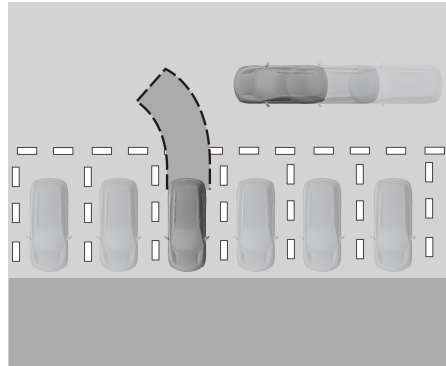

The rear cross traffic alert uses the rear side medium-range radar to monitor approaching targets. When a collision risk is detected between the vehicle and rear vehicles, motorcycles, bicycles, pedestrians, etc., the blind spot monitoring indicator on the corresponding exterior rearview mirror remains on or flashes, and it reminds the driver to react in time through sound and warning prompt at meter instrument interface to reduce the collision risk.

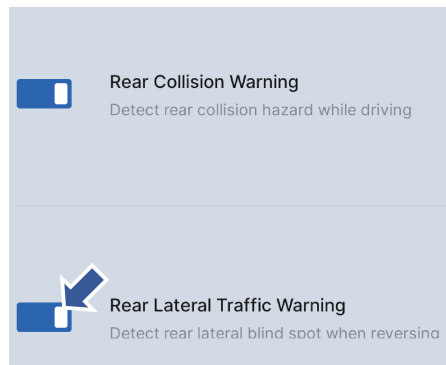

This function works in automatic rolling (vehicle reversing without pressing accelerator pedal) or slowly reversing scenarios where the gear shift lever is in reverse (R) gear or neutral (N) gear position.

When a possible collision is detected, the rear cross traffic alert function reminds the driver through alarm sound, indicator lights and warning prompt at meter instrument interface to respond in time, and automatically brakes when necessary to prevent the vehicle from colliding with the rear crossing vehicle when leaving the parking space.



Rear cross traffic alert is a driving assistance function, and its warning timing is affected by many factors such as the vehicle speed, the type of obstacles, the distance from the obstacles, the driving environment, the delay of system response, etc. The rear cross traffic alert function may not be able to give timely warning, or a missed warning or wrong warning may be provided. The rear cross traffic alert function cannot substitute the driver's driving and judgment.

**THIS PAGE IS INTENTIONALLY LEFT BLANK**

## Park Assist System (PAS)

The Park Assist System assists the driver to avoid hitting objects when parking.

### Front Parking Sensor\*

Park Assist System radar sensors on front bumper can detect barriers 0.7 metres away from front part of vehicle at most.

### Rear Parking Sensor

Park assist system radar sensors in the middle of the rear bumper can detect barriers 1.5m away from rear part of vehicle at most.



The Park Assist System cannot replace the vision of driver.

- The park assist system cannot detect objects below the bumper or vehicle, or objects too close or far away from the vehicle.
- The park assist sensor may not be able to detect children, pedestrians, cyclists or pets.
- The park assist system cannot detect tiny objects.
- If you do not pay attention to the surrounding conditions of the vehicle during parking, it may cause serious casualties and property damage. Even if the vehicle is equipped with a parking radar system, the driver must carefully observe whether there are obstacles before parking. ◀

### Alarm Volume Setting

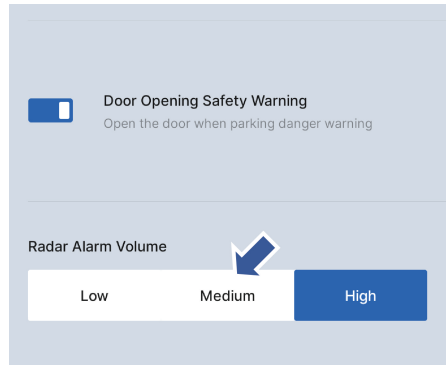

Click the following on the multimedia display:

**Vehicle Settings** → **Assisted Driving** → **Safety Settings** → **Pre-collision Assist**, and then select the radar alarm volume level in this interface. The three optional alarm volumes are low, medium and high respectively.

### How The System Works

When the park assist system works and obstacles enter the detection range, the detection results will be displayed on multimedia display in color blocks, with buzzer sound to remind. The beep sound indicates that there is an obstacle in front of the vehicle (if equipped with front parking sensor) or behind the vehicle. The closer the vehicle gets to the obstacle, the more rapid the beep sound becomes. When the distance is less than 30 cm, a continuous beep sound will be heard and "Please stop" will be prompted on the multimedia display.



Due to environmental factors, the detection performance of radar sensors of Park Assist System may be degraded in hot, extremely cold or humid weather. ◀

### When the System Cannot Work Normally

Please be aware that the radar sensor of Park Assist System may not alarm or may give wrong alarms under the following conditions:

#### When Barriers Cannot Be Detected

- The radar sensor of Park Assist System cannot detect net-shaped barriers like iron wires, mooring ropes and blocking net.
- The radar sensor of Park Assist System cannot detect low barriers like stone, wood blocks, etc.
- The radar sensor of Park Assist System cannot detect vehicles with a high chassis.
- The radar sensor of Park Assist System cannot detect soft objects like snow, cotton, sponge which can absorb the ultrasonic wave.
- The radar sensor of Park Assist System cannot detect barriers of some special shapes, such as pillars, trees, bicycles, angle steel, cornerstone and corrugated paper.

#### Situations In Which Wrong Alarm May Be Given

- Ice on the sensor surface of parking radar system.
- The vehicle is on a steep slope.
- The vehicle is fitted with high-frequency radio or antenna or they are used nearby.

- Horn sound of other vehicles, roar of engine or exhaust sound of vehicle are too close to the parking radar system sensor.
- Driving in snow or rain.

If the system still does not alarm when the vehicle approaches to the obstacle, and it is confirmed that it is not caused by the above situation, please contact an authorized PROTON e. MAS service outlet for maintenance.



- The radar sensor of Park Assist System can only detect closest barrier when there are several barriers. Please note whether the parking sensor of another side (left or right) detects other barrier when vehicle moves.
- The Park Assist System can only display the closest barrier when there are several barriers on the same side (front/rear). Please pay attention to the situation where the Park Assist System radar sensor detects multiple obstacles when vehicle moves.
- Do not use water gun to directly spray high pressure water and do not squeeze or impact the surface of Park Assist System radar sensor in other ways. Otherwise, it may cause faults. ◀

## 360 Camera

Camera images on the multimedia display allow the driver in vehicle to monitor the front/rear, left/right video images outside the vehicle in real time, and assists the driver in parking.



- When using the 360 Camera, pay attention to the surrounding conditions of the vehicle. The system can only be used as an auxiliary means for the vehicle. Do not rely only on the 360 Camera.
- Panoramic camera is vulnerable to environmental factors, such as fog, rain and snow, night and other low visibility environments. In such environments, panoramic camera system should be used carefully to ensure the safety of the surrounding environment before use.
- The 360 Camera has a blind area and may not be able to detect all obstacles around the vehicle. ◀

 This vehicle adopts wide-angle fish eye cameras, and the imaging model is bowl-shaped, resulting in the stretching deformation of 3D images at the splices, and overlapping of objects at the far end of the edge. ◀

## Panoramic camera

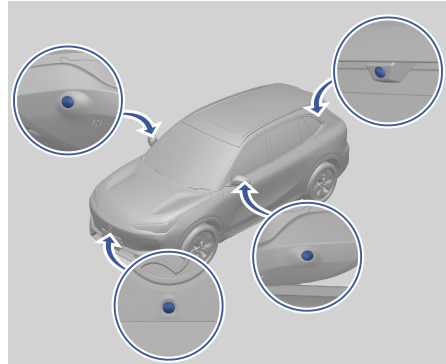

The panoramic video cameras are located around the vehicle body.

## Enter the panoramic image interface

- If the steering linkage function has been enabled in the panoramic image setting interface, when the gear is in the non-R position, toggle the turn lever.
- When the custom button function in the multimedia display has been set to panoramic image, press the custom button on the steering wheel.
- Click the panoramic image APP icon on the multimedia display.
- Through voice commands, for example, enter keywords such as "Hello PROTON, open panoramic image".
- Shift the gear to R position to enter the 360 Camera automatically.
- When the gear is in Drive (D)/Neutral (N), the vehicle speed is less than 15 km/h, and the obstacle ahead is less than 70 cm away from the vehicle, it automatically enters the panoramic image (Have Front parking radar).

- If the uphill hold control function has been turned on in the panoramic image settings, the panoramic image will be automatically turned on after the vehicle moves uphill at a low speed (less than 30 km/h) for a certain period of time.

 Only when the vehicle speed is less than 30 km/h, will it enter the panoramic image interface in the way above. ◀

### Exit the panoramic image interface

- Touch the “return” button of panoramic image interface on multimedia display.
- Shift the gear from R, N and D to P. If there is no operation within 5 seconds, the panoramic image exits.
- Turn on the panoramic image by shifting into reverse gear (R). When it is in non-R gear, the panoramic image exits when the vehicle speed exceeds 15 km/h.
- Through voice commands, for example, enter keywords such as "Hello PROTON, close panoramic image".
- If the panoramic image is turned on via toggling the turn level, and the view of panoramic image is not switched by other operations (excluding the toggle of left/right turn lever), when the turn lever is aligned, the panoramic image automatically exits.
- If the panoramic image is turned on via the front obstacle, if the speed exceeds 15 km/h, the panoramic image will automatically exit(Have Front parking radar).
- Enter the panoramic image through other operations (not activated by shifting into Reverse (R) and not triggered by front

obstacles to activate panoramic image). Exiting the panoramic image when the gear is in a non-reverse (R) and the vehicle speed exceeds 30 km/h.

- If the panoramic image is triggered by the uphill hold control function, the vehicle will automatically exit the panoramic image after driving on the flat road for a certain period of time.

### Setting Interface

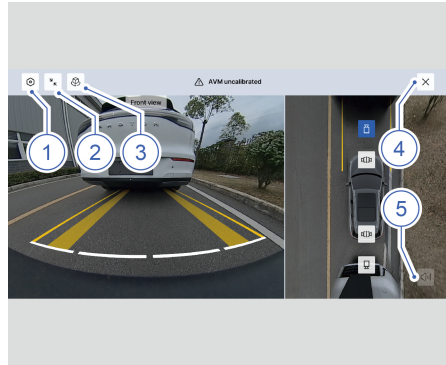

1. Settings  
Transparent car models, steering linkage, uphill hold control and 3D surround effects can be set.
2. Half screen/full screen switching  
Either half screen or full screen effect can be switched.
3. 2D/3D view effect  
Either the 2D view effect or the 3D view effect can be switched.
4. Back  
Exit the Panoramic Image Interface
5. Radar alarm sound  
The radar alarm sound can be turned on or off.

 In addition to function buttons above, directly touch camera icons around the panoramic image vehicle model to quickly change the viewpoints of images. ◀

**THIS PAGE IS INTENTIONALLY LEFT BLANK**

## Front A/C Control System

### Sub Instrument Panel A/C Control Panel

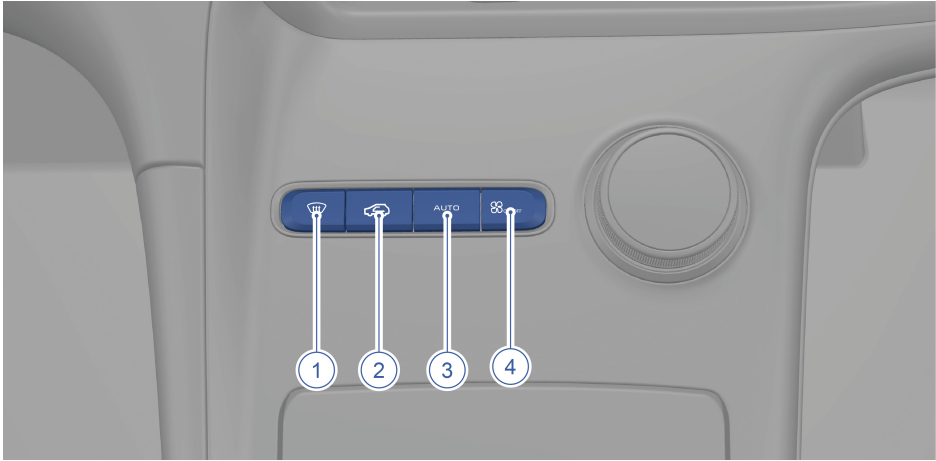

### A/C Control Panel in Multimedia Display

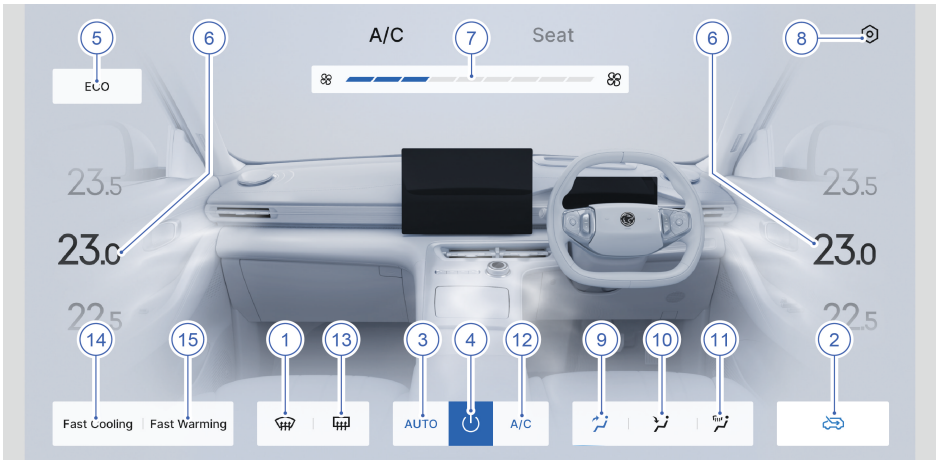

1. Front windshield defrosting/defogging button
2. Interior/exterior circulation switching button
3. AUTO button
4. Air conditioning on/off button
5. ECO button
6. Temperature adjustment button
7. Air volume adjustment button
8. Setting button
9. Air out mode face-blowing button
10. Air out mode foot-blowing button
11. Air out mode window-blowing button
12. A/C button
13. Exterior rearview mirror/rear windshield defrosting/defogging button
14. Rapid cooling button
15. Rapid heating button



In the air conditioning control panel on the multimedia display, the window blowing button, face blowing button and foot blowing button of the air outlet mode can all be used alone or in combination as needed. ◀

## Description of Front A/C Control System Buttons

### 1. Front windshield defrosting/defogging button

To quickly remove fog or frost from the front windshield, direct air to the front windshield. For optimal effect, clear all ice and snow from the front windshield before defogging. Adjusting the air volume adjustment button in defogging mode will increase or decrease the air volume accordingly, and the air outlet mode will remain in the window-blowing mode.

When using the front windshield defrosting/defogging function, the A/C and external circulation will be automatically turned on (and cannot be switched). Before turning on the front windshield defrosting/defogging function, if the A/C is turned off or in AUTO mode, the air volume will be manual air volume 6th gear; If the A/C is turned on in manual mode or AUTO mode, and the air volume is less than 6th gear, the air volume will be manual 6th gear; If the A/C is turned on in manual mode or AUTO mode, and the air volume is greater than or equal to 6 gear, the air volume will remain unchanged at the current air volume. In order to maintain the defrosting/defogging effect, please do not turn off the A/C and external circulation.

When the A/C is turned off, the front windshield defrosting/defogging button is operated, and the A/C is activated to perform the front windshield defrosting/defogging function.

### 2. Interior/exterior circulation switching button

Press/click this button to achieve manual switching between external circulation (fresh air) and internal circulation. When in the external circulation, The actual state of the internal and external circulation dampers will be automatically adjusted according to the temperature control needs in the vehicle.

When the A/C is turned off, the A/C is still turned off after pressing/clicking the internal and external circulation switch button, but the internal/external circulation will switch.

### 3. AUTO button

According to the temperature required by the body, adjust the temperature button and select the temperature. Press/click the AUTO button, and the A/C will automatically control four functions: internal and external circulation, air outlet mode, air volume, and A/C to achieve the desired temperature; At this time, if the air outlet mode is manually adjusted or the defrosting/defogging button of the front windshield glass is pressed, or the air volume is manually adjusted, or the AUTO button is pressed/clicked again, the AUTO button indicator light will turn off and the automatic A/C will be exited. When the A/C is turned off, the A/C is activated to enter the fully automatic control mode after pressing/clicking the AUTO button; Set the temperature to the state before the A/C is turned off.

### 4. Air conditioning on/off button

Press/click this button to turn on/off the A/C.

5. ECO button  
Click this button to turn on/off the A/C ECO mode. After being turned on, the comfort of the A/C will be reduced to some extent at the current set temperature.
6. Temperature adjustment button  
Slide up to decrease the temperature and slide down to increase the temperature in the temperature adjustment area. Each time one grid is adjusted to change by 0.5 degrees Celsius, and the temperature setting range is 15.5 ~ 28.5 degrees Celsius.
7. Air volume adjustment button  
Click the A/C air volume progress bar and select the air volume according to personal needs.
8. Setting button  
Click this button to turn on/off the A/C self-drying when locking function in this interface.
9. Air out mode face-blowing button  
Click this button to select the air outlet mode to face blowing mode.
10. Air out mode foot-blowing button  
Click this button to select the air outlet mode to foot blowing mode.
11. Air out mode window-blowing button  
Click this button to select the air outlet mode to window blowing mode.
12. A/C button  
Press this button to turn on/off the A/C cooling system, and the A/C button indicator will turn on. Click this button again, the button indicator light goes out, and the cooling mode is turned off.  
When the A/C is turned off, click the A/C button and the A/C is activated to run.
13. Exterior rearview mirror/rear windshield defrosting/defogging button  
When the vehicle power is set to ON or the vehicle is started, click this button to turn on or off the defrosting/defogging function of the exterior rearview mirror/rear windshield. When the defrosting/defogging function of the exterior rearview mirror/rear windshield is turned on, the button indicator light lights up. Click the button again to turn off the defrosting/defogging function.
14. Rapid cooling button  
Click this button to turn on/off the rapid cooling mode.
15. Rapid heating button  
Click this button to turn on/off the rapid heating mode.



- If A/C performance is lower than expected, check the surface of the radiator (located on the front-end cooling module) for dirt or insect aggregation. Please go to the PROTON service outlet for cleaning.
- Placing a shelter in front of the front compartment cover reduces airflow into the radiator, thus reducing air conditioning performance.
- Do not allow leaves or other sundries to block the air inlet.
- If the sound of the blower is heard in the vehicle after locking the vehicle, it is in a normal state and is expected to keep it for one minute. After the A/C is running, the water vapor from the evaporator and

A/C duct will be blown out to prevent odor after deposition.

- When starting the vehicle in a cold start state during winter, if the initial air volume is small after turning on the rapid heating, it is a normal state. Under automatic A/C, the air volume is automatically adjusted according to the heating needs.
- When heating under extremely cold conditions, the air output may be less than the set air volume in a short period of time at the beginning, which is a normal phenomenon. Its purpose is to achieve rapid temperature rise and obtain a better experience. ◀

### Temperature and humidity/ rainfall/sunlight sensor

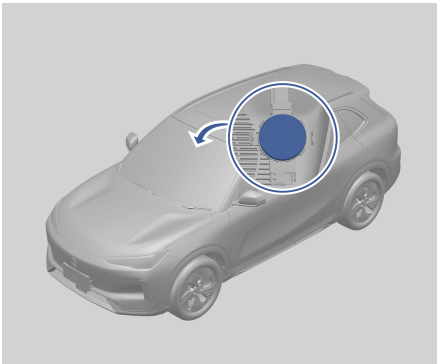

The sensor is used to control the temperature inside the vehicle, on and off of automatic wiper wiping and automatic light.

- i** Keep the sensor area clean. Do not paste foreign objects such as stickers. Otherwise, the temperature control system, wiper automatic wiping, and automatic light will not work properly. ◀

## Air Vent

### Adjustment of Air Vent

#### Front Air Vent

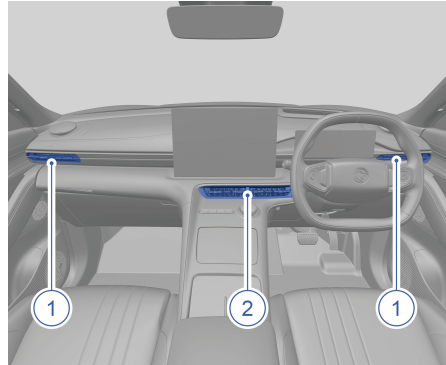

1. Side air vent
2. Centre air vent

#### Rear air vent

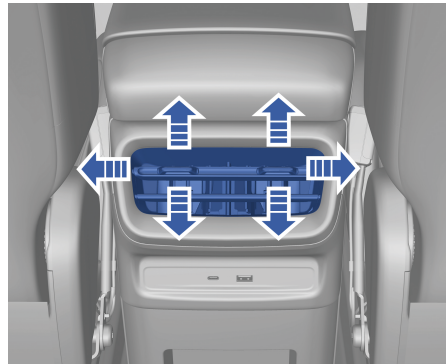

Adjust the wind direction by changing the direction of the air vent grille up, down, left, and right.

The air flow can be turned off by adjusting the blades.

## A/C Settings

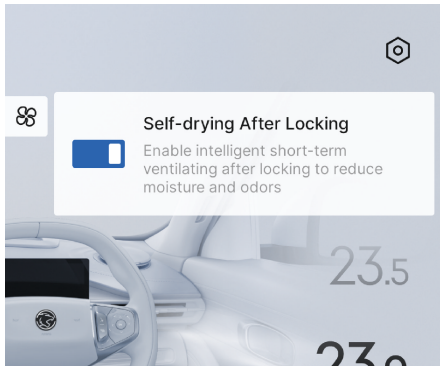

Click the following on the multimedia display in sequence: A/C → Settings, and then enable or disable the A/C self-drying function after the vehicle is locked.

### A/C Self-drying when Locking

When the self-drying function is enabled, the vehicle is locked and the conditions are met, the air conditioner system will automatically turn on the A/C blower for drying to avoid the odor caused by the humidity and mildew of the evaporator.

**THIS PAGE IS INTENTIONALLY LEFT BLANK**

**THIS PAGE IS INTENTIONALLY LEFT BLANK**

## Maintenance

### Regular Maintenance

It is recommended to monitor the vehicle status regularly to keep your vehicle in the best condition.

### Maintenance of Doors

The door hinges needs to be smeared with grease regularly. Otherwise, there may be abnormal noise when opening and closing the door.

### Maintenance of Window Glass

The window glasses can be cleaned with glass cleaner to clean the surface of the bright strip. Never use chemicals containing n-heptane and butanone for cleaning!

### Maintenance of Sunroof Glass\*

The sunroof can be cleaned with glass cleaner for the glass panel of sunroof. Do not use viscous cleaners!

### Maintenance of Sunroof\*

- If you often use sunroof in windy and dusty environments, use wet sponges regularly to clean the dust and soil around the glass strips.
- If the vehicle is parked or the sunroof is not being used for a long period of time, apply fine talcum powder or specific lubricant to clean the strips around the sunroof.
- When washing the vehicle, check whether the sunroof strips, drain holes and grooves are covered by dust, leaves, branches and other foreign matters. Remove and clean them if any.

## Replacement of Key Battery

### Replacing Smart Key Battery

Battery in the smart key should be replaced when the remote control distance of smart key is very short, unable to remotely control the vehicle, or vehicle cannot recognize the smart key due to low battery power.

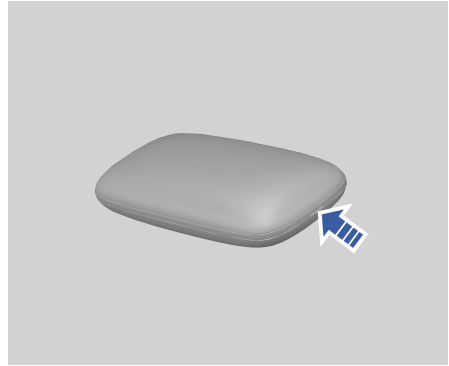

1. With the striped back cover facing upwards, insert a flat screwdriver with a width similar to the opening into the opening at the back of the smart key. Then grip the handle of the screwdriver tightly and pry it inward until the flat part of the screwdriver is fully inserted into the key. Then lift the handle upwards with force to open the back cover;



2. Use a flat screwdriver to insert the back of the battery cover plate and pry open the battery cover plate;



3. After replacing the battery with a new one, buckle the battery cover plate, noting that the positive pole of the battery faces the back cover. Smart key battery model: 3V, CR2032;
4. Engage the two halves of key cover in place.



- Replacing the battery yourself may damage the key. If necessary, it is recommended to contact the PROTON Service outlet for replacement.
- If the replaced key still cannot be used, contact the PROTON service outlet for maintenance.
- To prevent children from swallowing the replaced battery, keep the battery out of the reach of children. ◀



Dispose of waste batteries according to local regulations to avoid damaging the environment. ◀

## Front Compartment Hood

### Opening the Front Compartment Hood

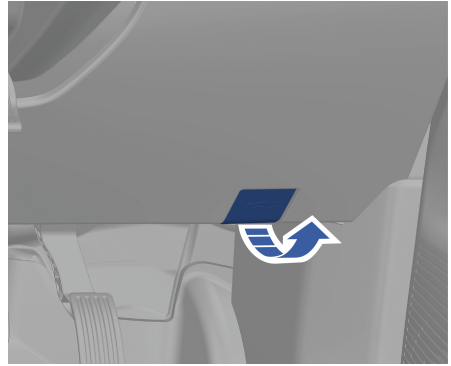

1. Pull the opening lever of the front compartment hood at the lower right side of the driver instrument panel;

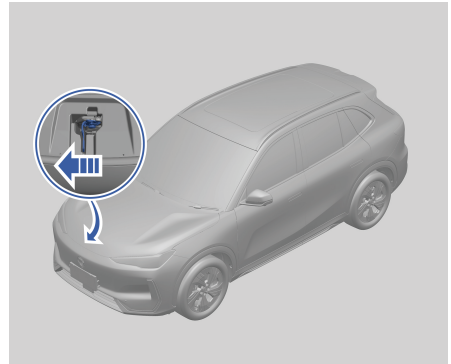

2. Push the latch of the front compartment hood lock safety hook in the direction of the arrow shown;

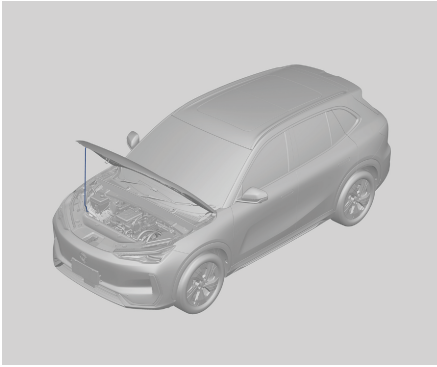

3. Lift the front compartment hood to open and use the provided support rod to support the front compartment hood.

### Closing the Front Compartment Hood

**i** Before closing the front compartment hood, it is required to check if any service tools, protection sheet, etc. have been left in the front compartment, and make sure that all filler caps are closed. ◀

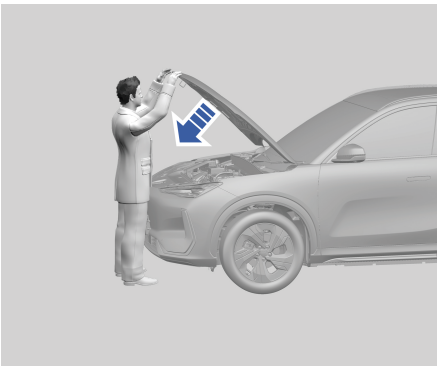

1. Remove the front compartment hood support rod and secure it in place;
2. Close the front compartment hood down and hear a click to indicate that the front engine compartment hood is locked;

3. After closing the front compartment hood, verify that it has been securely locked by trying to lift the front edge of the front compartment hood.

If it is not properly locked, open the front compartment hood again, and then close it. Do not forcibly press the hood.

**!** Do not drive the vehicle with the hood not properly closed. ◀

## Coolant



Be sure to park the vehicle on flat ground when inspecting the coolant level. The coolant level in the coolant expansion tank should be between MAX and MIN marks. If the coolant level is below the MIN mark, top up some coolant into the expansion tank according to specified procedures as follows:

Before you open the pressure cap of coolant expansion tank, ensure the cooling system (including the pressure cap of coolant expansion tank and the upper hose of radiator) has completely cooled down.



1. Slowly turn the pressure cap counter-clockwise. If you hear any “fizz” sound, open the pressure cap after the “fizz”

sound disappears. The “fizz” sound indicates that a pressure still exists.

2. Continue turn the pressure cap counter-clockwise and remove it.
3. Slowly fill in coolant until the coolant level in the coolant expansion tank reaches the position between the MAX and MIN lines and the coolant level no longer drops.
4. Start the vehicle, turn on the A/C system, and let the remaining air of the coolant system being removed through the operation of the electric water pump;
5. Observe drops of coolant in the coolant expansion tank and replenish the coolant in time. The coolant level in the coolant expansion tank should be kept between the MAX and MIN marks;
6. Observe the vent under the pressure cap of coolant expansion tank. Wait until the coolant continuously flows out of the vent and the coolant level in expansion tank no longer drops. Tighten the pressure cap to complete the coolant refilling process.

 Only refill with certified ethylene glycol-type coolant. Damage or failure caused by the use of low quality coolant or non-compliant coolant mixture is not covered by the warranty. ◀

## Brake Fluid

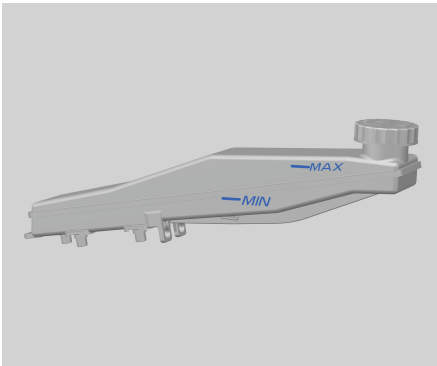
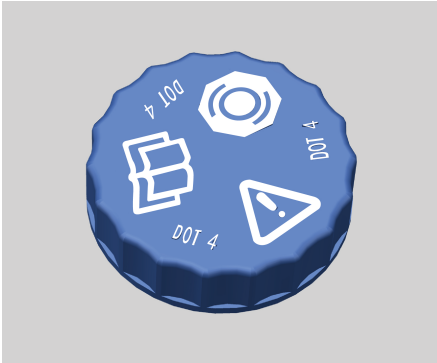

Check the brake fluid level from time to time. The brake fluid level should be between MAX and MIN marks.

If the brake fluid level is lower than the MIN mark, turn the reservoir cap counterclockwise to open and slowly pour in the brake fluid to prevent the brake fluid from overflowing. In case the brake fluid accidentally spills out, immediately clean it; otherwise, the spillage may cause damage to the affected parts in the front compartment.



- Brake fluid is harmful to the human body. In you accidentally come into contact with

the brake fluid, rinse it immediately with plenty of water. If you swallow the brake fluid by mistake, seek for medical attention immediately.

- Brake fluid leakage causes the brake fluid level to drop. Go to an authorised PROTON e.MAS service outlet for maintenance as soon as possible.
- Apply the brake fluid of the manufacturer and brand designated by PROTON; otherwise, it will seriously damage the parts of the brake hydraulic system and affect the braking performance and distance. ◀

## Washer Fluid

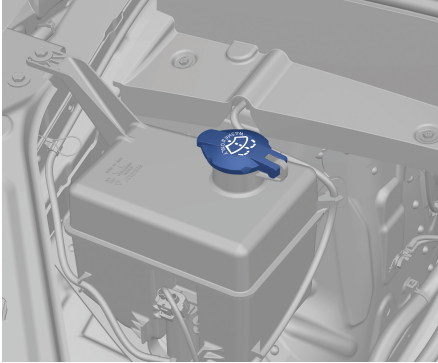

Open the washer fluid cap with a washer sign engraved on it. Add appropriate amount of washer fluid.

▶ The freezing point temperature of the washer fluid should be at least 10 °C lower than the local minimum temperature.



▶ Do not add any liquids such as soapy water instead of washing liquid, otherwise, the paintwork of the vehicle body may be damaged. It is recommended to use certified washer fluid for windshield glass. ◀

## Wiper Blades

### Replacement of Wiper Blades



- Grease, silicon and petroleum products will affect the wiping performance of wiper blades. Clean the wiper blades with warm soapy water. Check the condition of wiper blades regularly.
- Clean and wash the windshield glass frequently. Avoid using wiper blades to wipe when there are sands on the windshield glass; otherwise, the wiping effectiveness and the service life of the wiper blades will be affected.
- If the rubber is found hardened or cracked, or the wipers leave water streaks or cannot wipe a certain area on the windshield glass, replace the wiper blades.
- Before replacing wiper blades, clean the windshield glass regularly with certified washer fluid of windshield and make sure that the windshield glass is thoroughly cleaned.
- Replace the wiper blades of the same specification as the original wiper blades.
- Before using the wiper and if the wiper or windshield glass is covered with ice, frost or snow, clean the ice and snow on the wiper and windshield glass; to avoid damaging the wiper.
- When the windshield is dry or there are hard objects on the surface, do not operate the wipers. Otherwise, it may damage the wiper blades and windshield glass. ◀

## Replacing the Front Windshield Wiper Blades

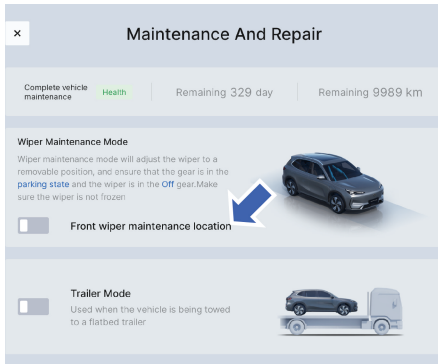

1. When the vehicle is stationary and the wiper combination switch is in  position, click the following on the multimedia display in sequence: Vehicle Settings → My Car → Maintenance and Repair; then turn on the front wiper service position function in this interface, and the wiper automatically moves to the service position;

 When the front wiper or the front windshield washer is activated, the front wiper will return to its original position. ◀

2. Raise the wiper arm of the front windshield wiper blade away from the front windshield glass.

 While the front windshield wiper arm is raised, do not open the front compartment hood. Otherwise, the wiper arm or the hood may be damaged. ◀

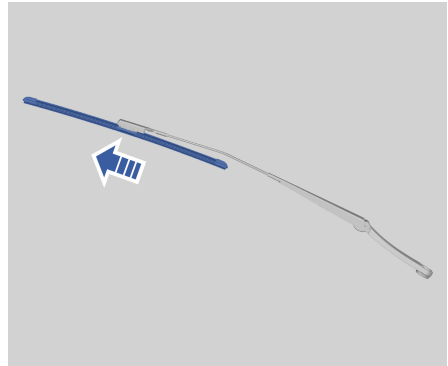

3. While pressing the unlocking clip of the wiper blade, pull out the wiper blade along the arrow direction to separate it from its wiper arm;

4. Remove the wiper blades;

 When front windshield wiper blade is not mounted, do not let the wiper arm gets in contact with the windshield glass; otherwise, the windshield will damage. Damage caused thereby is not covered by warranty. ◀

5. Install new wiper blades in reversed sequence of step 2 to 4.

6. Exit the wiper service position function by turning off the front wiper service position switch in the multimedia interface.

## Replacing the Rear Windshield Wiper Blade

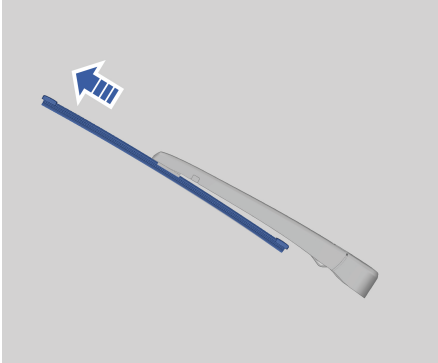

1. Raise the wiper arm of the rear windshield wiper away from the rear windshield glass.
2. While pressing the unlocking clip of the wiper blade, pull out the wiper blade along the arrow direction to separate it from the wiper arm;
3. Install new rear windshield wiper blade in reversed sequence of step 1 to 2.

## Low-voltage Battery

### Maintenance of Low-voltage Battery

This vehicle is provided with maintenance-free low voltage battery.

To extend the service life of low-voltage battery and ensure the normal operation of electric system, the following suggestions are given:

- When driving in a cold region, prevent the low-voltage battery from fully discharged; to avoid the electrolyte from frozen.
- Avoid overcharging or leaving the low-voltage battery in low charge condition for long time.
- In case the low-voltage battery is low in charge level, recharge it in time via external battery charger.
- Keep the low-voltage battery away from any heat and open fire sources. When the low-voltage battery is being charged or used, make sure there is enough space for ventilation, to prevent any casualties.
- Install the low-voltage battery in the vehicle securely to prevent vibration.
- Inspect whether the clamps of low-voltage battery terminals are securely installed and well contacted, to avoid sparks which may cause the low-voltage battery to explode.
- Park the vehicle in a cool, ventilated, clean and dry environment. If the vehicle is parked in closed and humid environment for long time, the vehicle parts may easily get rusty and become aging before

time. Follow the recommendations and requirements to carry out regular maintenance on the vehicle in time.

## Replacement of Low-voltage Battery

When replacing the low-voltage battery, make sure to use the same model and specification of low-voltage battery. Contact the PROTON e.MAS service outlet for removal, replacement and installation of the low-voltage battery.

 Different models of low-voltage batteries have different terminals. In case the low-voltage battery terminals and the wiring harness terminals is mismatched, this will lead to failure to tighten, and there is a risk of breaking down. ◀

 After the low-voltage battery is replaced, hand over the used battery to an authorised PROTON e.MAS service outlet for disposal, or deliver it to the certified collection depot. There is a highly corrosive toxic substance in low-battery. Please keep the battery in its upright position when transporting and storing. ◀

 If the low-voltage battery has overheating failure, it may produce harmful gases. Leave the vehicle as soon as possible. ◀

## Waking up the System

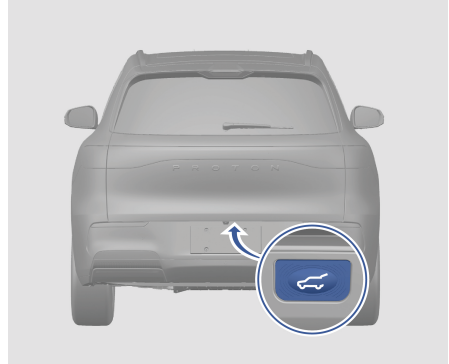

The vehicle system will enter sleep mode after long-term storage. If the intelligent key cannot be operated to locate and unlock the vehicle, it is necessary to press and hold the external tailgate switch to wake up the low-voltage battery. Now you can operate the intelligent key for normal operation

### Power Battery

As one of the main power sources, the power battery can be charged and discharged multiple times. Charging methods mainly include external power supply charging and energy recovery charging.



When the vehicle is stored for a long time, ensure that the charge level of the power battery is kept higher than 20%, and ensure that the low-voltage battery is recharged. ◀



- To keep the power battery in the best condition, if the storage period of the vehicle exceeds three months, or the power battery meter gauge shows that the charge level is too low, the power battery should be recharged. Otherwise, the power battery may be excessively discharged and the performance of the power battery may deteriorate. Vehicle failure and damage incurred there of will not be covered by warranty.
- The thermal runaway of the power battery will produce harmful gases. Please leave the vehicle immediately. ◀

### Caution

Power battery is a high-voltage energy storage device, which is dangerous. Non-professionals and improper operation and use may cause serious consequences such as electric shock, burning and explosion.

Non-professional personnel should not install, repair and abuse the power batteries; it should only be operated by professional technicians of PROTON e.MAS service outlet. Warranty will not be given for any

damage to the power battery and other losses caused by using the power battery not in accordance with the specified requirements or exceeding the specified scope of use.

#### 1. Moisture-proof and water-proof

The power battery contains many high-voltage control circuits and cells. Therefore, avoid soaking the power battery in any liquid and make sure no humid air enter the power battery.

#### 2. Environmental insulation

When the vehicle is parked, the surrounding area should be insulated, ventilated and kept away from any flammable materials to prolong the service life of the power battery and improve the safety performance of the power battery.

#### 3. Shock-proof and impact-proof

Please drive carefully when the road conditions are poor to prevent the power battery from colliding to avoid damage to the power battery.

### Recycling Process

Used power batteries need to be properly recycled. In the process of vehicle maintenance and repair, power batteries that meet the following conditions need to be recycled:

1. During repair and maintenance of the vehicle, PROTON e.MAS service outlet need to check the capacity and status of the power battery and determine whether the power battery that should be recycled. PROTON shall assume the main responsibility and recycle the power batteries according to rules and

regulations imposed by the local authority.

2. If it has been confirmed that the power battery cannot continue to be used in the vehicle anymore and the power battery meets the conditions for cascade utilization, then it can be recycled and subjected to cascade utilization.
3. If the power battery severely failed or damaged, and cannot be utilized for cascade utilization, it will be sent for recycling process.

The power battery recycling process is: recycling and subsequent processing by PROTON e. MAS service outlet or a third-party recycling agency appointed by PROTON.

 Do not sell, transfer or modify the power batteries. PROTON e. MAS service outlet shall be responsible for recycling the power battery in case of accidents.



 If the power battery is not properly recycled, the following cases may occur and result in serious personal injury or death:

- Illegal scrapping or disposal of power batteries will harm the environment. People may suffer electric shock from touching the high-voltage parts.
- If the power battery is improperly used or modified, accidents such as electric shock, heat, smoke, explosion and electrolyte leakage may occur. ◀

## Tyre

### Tyre Inspection

#### When to Check Tyre

Inspect all tyres at least once every month.

#### How to Check Tyres

Check the tyre pressure with a quality compact type of tyre pressure gauge. Check the tyre inflation pressure when the tyre is cold. Remove the valve cap from the tyre valve. Press the tyre pressure gauge firmly onto the valve and take the pressure reading.

If the cold tyre inflation pressure meets the recommended pressure value on the tyre pressure label, no adjustment is required.

If the cold tyre inflation pressure is too low, continue to inflate the tyre to the recommended pressure value.

If the tyre is overinflated, press the metal valve core of the tyre valve to deflate the tyre to the recommended pressure value.

Use the tyre pressure gauge to check the tyre pressure again. Always install the valve cap back on the valve core. Valve caps keep dirt and moisture out.

#### How to Check Tyre Wear

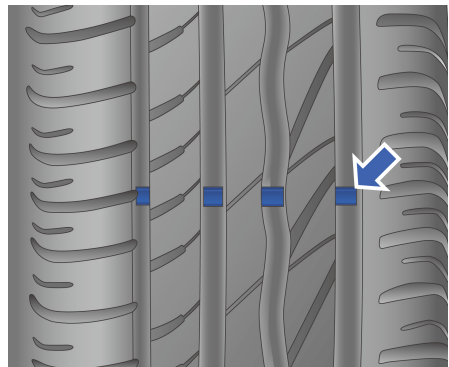

The tread wear indicator will appear when the tyre has worn up to 1.6 mm or less of tread. Tyres should be replaced as soon as possible after the tyre wear has reached its limit.

If uneven tyre wear is found, or some continuous vibration is felt while driving, go to an authorized PROTON e.MAS service outlet for inspection.

Conduct a wheel balancing when installing new tyres.



If the tyres with shallow tread patterns or exposed wear marks are used continuously, it may cause the braking distance to increase, steering failure, burst tyre, etc., which easily can cause traffic accidents. ◀



Please dispose the used tyres in accordance with the rules and regulations of your local authorities. ◀

### Tyre Pressure

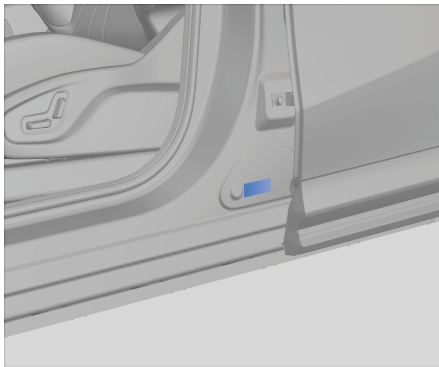

The tyre pressure label are posted on the lower side of the centre pillar of this vehicle, showing the recommended tyre inflation pressures.



The tyres work effectively only when they have correct inflation pressure. Under inflation or over inflation may

adversely affect the service life of the tyres and the handling performance of the vehicle, causing the vehicle to lose control. ◀

### Tyre Rotation

The tyres of the vehicle shall be transposed or rotate position every 10,000 km of distance travel.

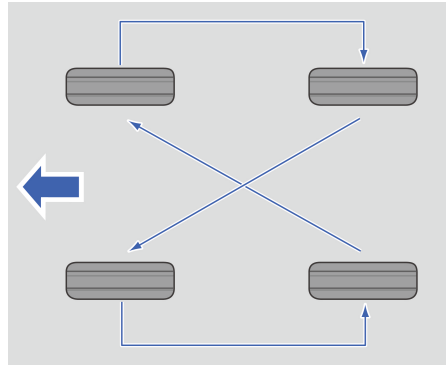

Carry out correct tyre rotation according to the sequence shown in the figure. After complete the tyre rotation, adjust the inflation pressure of the front and rear tyres to the pressure as shown in tyre pressure label of the vehicle.



The wheels need to be installed correctly. After tyre rotation, adjust the tyre pressure. ◀

### Wheel Alignment and Wheel Balancing

It is necessary to inspect wheel alignment if abnormal wear of tyres or deviation is found. It is necessary to re-balance the tyres and wheels if the vehicle jolts when it is driven on smooth road surface. Contact an authorised PROTON e.MAS service outlet for maintenance as soon as possible.

## Flat Tyre

When a tyre bursts during driving, the following phenomena will occur. Please take actions accordingly:

1. If a front tyre bursts, the dragging of the flat tyre will cause the vehicle to deflect towards the side of the burst tyre. Please release accelerator pedal and hold the steering wheel tightly. Make a turn to keep the vehicle on the original lane, then depress the brake pedal gently to park the vehicle on a safe road as possible as you can.
2. Release the accelerator if the rear tyre bursts. Carefully turn the steering wheel to your expected driving direction to maintain the vehicle under control. The vehicle may jolt and produce noises, but the steering still can be under controlled. Then, depress the brake pedal carefully and park the vehicle on the provided emergency lane or safe roadside as possible as you can.

If you find that the tyre has slow air leaking, follow these steps:

1. Drive the vehicle slowly to a safe and flat road surface to avoid further damage to the tyres and wheels.
2. Turn on the hazard warning lamp and place a triangle warning device at an appropriate position;
3. Use the quick tyre repair tool to repair the tyre.



To prevent the vehicle from moving, it is necessary to take the following measures:

- Put the gear in Park (P) or Neutral (N) position;
- Make sure nobody is inside the vehicle.
- Before using the quick tyre repair tool to repair tyres, it is necessary to place stoppers at the other front and rear tyres. ◀
- Activate the parking brake (if fitted).

### Exterior Cleaning

Washing the vehicle frequently helps to protect the appearance of the vehicle. When washing the vehicle, park the vehicle in a cool shaded area and turn off the power mode. Avoid washing the vehicle under direct sunlight. If the vehicle is exposed to direct sunlight for a long time, it is necessary to wait for the vehicle body to cool down before cleaning it.

When using an automatic car washer facility, make sure to follow the instructions given by the car washer operator.



- To prevent damage to the vehicle paint, any corrosive substances (such as bird droppings, resin, insects, asphalt spots, paving salt, industrial dust, etc.) should be cleaned immediately. If necessary, use industrial alcohol to remove asphalt spots and obstinate oil stains, and then immediately rinse with clean water and mild neutral soap solution.
- Do not use chemical solvents containing ethanol or strong detergents to scrub the exterior lamp cover.
- Do not clean the exterior lamp cover when the surface is hot or exposed to direct sunlight. It is necessary to wait for the exterior of the vehicle body to cool down before cleaning the exterior lamp cover of the vehicle. ◀

### Cleaning the Vehicle with High-pressure Washer

- Before washing the vehicle, make sure the vehicle charge port lid is properly closed.

- Follow the given instructions on how to use the high-pressure washer, and paying attention to the spraying pressure and distance; the nozzle must be at least 30 cm away from the vehicle body surface. Do not aim the high-pressure water constantly at one position; keep moving the nozzle while spraying the water. Avoid spraying high-pressure water to the vehicle parts which may cause severe damage. Do not spray the nozzle directly to the charging port.
- Do not use "cluster nozzles" to clean the vehicle.
- Do not aim the nozzle directly or indirectly inside the front compartment. High-pressure water can cause damage to the electrical components in the front compartment or cause some parts cannot work normally.
- Do not aim the nozzle to the connector of the chassis (especially the orange high-voltage harness connector).
- Do not clean the front camera and sensor with a high-pressure washer or a steam washer, to avoid damage.
- Do not spray high-pressure water to the painted bumper and soft parts such as rubber hoses, plastic parts, and insulating materials at close range.

### Clean the Vehicle with Automatic Car Washer Facility

- Before proceed with automatic car washing facility, consult with the automatic car washer operator for any possibility of damage, especially if additional parts are mounted on the exterior of the vehicle.

- Before start washing the vehicle with automatic car washing facility, close the windows, sunroof (if equipped), automatic wipers and fold the exterior rear-view mirrors (side mirrors).
- The paint of vehicle body can withstand the washing of the automatic washer, but the impact on the paint must be noted. The influence mainly depends on the structure of the automatic washer, the cleaning brush, the filtering condition of the cleaning water, and the type of cleaning agent and wax solvent. If the paint surface of the vehicle body is darkened or scratched after washing, the operator should be notified immediately to make corrections.
- When selecting an automatic car washer facility to clean the vehicle, choose a non-contact car automatic washer type. This type of the car automatic washer does not have any part (brushes, etc.) that may contact the vehicle surface.

## Interior Cleaning

Regular vehicle interior cleaning helps to improve the condition inside the vehicle cabin. Within certain period of time, dust and dirt may easily accumulate on interior trims such as carpet, fabrics, leather and plastic surfaces, and can cause defect these trims if it is left for a long time. Any stains should be cleaned immediately, especially on light-colored interior trims, as they may become solid rapidly under extremely high temperature. Remove any accumulated dust on small buttons and knobs with a handy soft brush.

Only use certified cleaning solvent to clean the interior trim surface. Otherwise, it may cause permanent defect to the vehicle. It is necessary to spray cleaner directly on the cleaning cloth to avoid spraying excessively. Wipe off the cleaning solvent immediately if you accidentally spray it on the surface of other parts in the vehicle.

The temperature of heat blower used to install tinted film is extremely high. Do not use the heat blower on the interior trims when installing the tinted film; otherwise, the affected interior trims will damage. Before installing tinted film, make sure all gaps have been sealed to prevent water stains from flowing into the gaps and cause electrical failure.

 When you clean the glass surface on the vehicle, do not use abrasive cleaning solvents; otherwise, the glass can get scratched and/or the rear windshield defogger will damage. Only use soft cloth and certified glass cleaning solvent. ◀

Detergent contains solvent which may coagulate on vehicle interior trims. Please read

and comply with all safety instructions on the labels before using detergent.

Open doors and windows to keep good ventilation when cleaning the vehicle interior trims.

Take note the following when cleaning the interior trims:

- Do not clean dirt on trim surface with a knife blade or other sharp objects.
- Do not use a scrubbing brush to clean; otherwise, the interior surface may damage.
- Do not wipe the trim surface with strong force; it may not improve the cleaning effect but will damage the interior trims instead.
- Only use mild neutral soap. Avoid using strong detergent or degreaser soap. Too much soap may leave stains and easy to absorb dirt.
- Do not soak the interior trims when cleaning.
- Do not use organic solvents such as naphtha or alcohol; otherwise, these solvents will damage the interior trims.

### Fabric/Carpet

For dust and dirt, clean them with vacuum cleaner fitted with soft broom head. For stubborn stains, try to remove them with clean water or soda water first. Before cleaning, use a proper method to remove these stains:

- For liquid stains: Wipe residual stains gently with tissue to fully saturate and absorb the liquid stain on the tissue.
- For solid dry stains: Remove as much as possible with hand, and then remove the remaining with a vacuum cleaner.

Cleaning steps:

1. Soak the clean lint-free white cloth in water or soda water.
2. Wring the cloth to remove residual water.
3. Use the wet cloth to gently scrub from edges to the middle until no more stain marks are left on the fabric or carpet.
4. If the stains cannot be wiped off thoroughly, repeat the above cleaning operations with mild soap water.

If stubborn stains still cannot be removed thoroughly, consider to use synthetic fabric cleaner or detergent; test the cleaning solvent for color fastness on an invisible position in the vehicle. If the cleaning effect is good, proceed to clean the entire surface. After cleaning, use a tissue to absorb residual water on fabrics or carpets.

### Leather Cleaning

Use a wet soft cleaning cloth to remove dust. To clean more thoroughly, use soft cleaning cloth dipped in neutral soap water. Please let the leather dry in air, do not dry it by baking, and do not clean leather with steam.

Do not use detergents or polishes on leather. Otherwise the appearance and hand feel of the vehicle interior trims may be permanently changed. Do not use silicon-based, wax-based or organic solvent-containing products to clean the vehicle interior trims, which may cause uneven gloss of leather and affect the appearance of the interior trims. Be sure not to use shoe polish on leather.

## Instrument Panel and Other Plastic Surfaces

Do not use detergents or polishers on plastic surfaces. Otherwise, it may permanently affect both appearance and surface texture of the interior trims . Some car care products may enhance the glossiness of instrument panel and thus cause reflection on the windshield glass, which may severely affect your vision through the windshield when driving.



Do not use any cleaning solvent containing alcohol or strong oxide chemicals to wipe the interior trims. ◀

## Fault of Headlamps

This vehicle is equipped with LED headlamps. If any abnormalities or damages are found in the headlights, go to the PROTON e.MAS service outlet for inspection or replacement if necessary.

**i** When there is a temperature difference between inside and outside of the combination lamp lens, such as when in rainy days or when washing the vehicle; the inside lens may temporarily get foggy. This is normal. The fog will momentarily dissipate after you turn on the headlamps. If the fog does not dissipate, contact an authorised PROTON e.MAS service outlet for countermeasure. ◀

## Replacement of Fuse

### Inspection and Replacement of Fuse

The following maintenance method can only be performed by certified well trained technician. If you are not qualified to perform these procedures, please consult your authorised PROTON e.MAS service outlet for maintenance whenever possible. ◀

If any electrical components are not working, it is possible that the fuse has blown. If this happens, it is recommended to check as follows and replace the fuse if necessary:

1. Turn off all electrical equipment, switch the vehicle power mode to OFF position;
2. Shift the gear in Park (P), with the vehicle in a non high-voltage state and the vehicle stationary. Open the front compartment hood, pull out the red 10A BECM fuse, close the doors, press the lock button/car search button on the intelligent key and put the vehicle power to OFF position. Wait at least 5 minutes to ensure the high-voltage system is fully powered off;

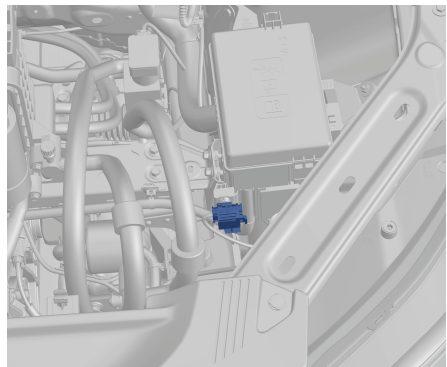

3. Disconnect the low-voltage repair switch in the front compartment;

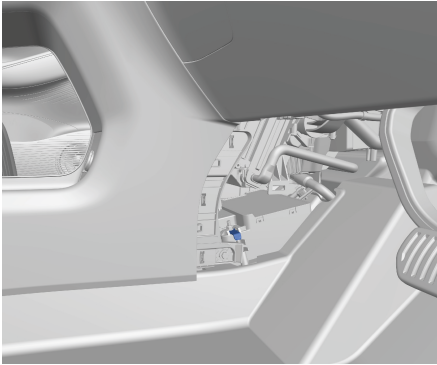

4. Open the driver door and remove the cover under the front centre console of instrument panel as shown in above picture. Disconnect the negative cable from the negative terminal of the low-voltage battery.



5. Clamp the fuse head with fuse clip to remove the fuse, and check whether the metal wire is blown;

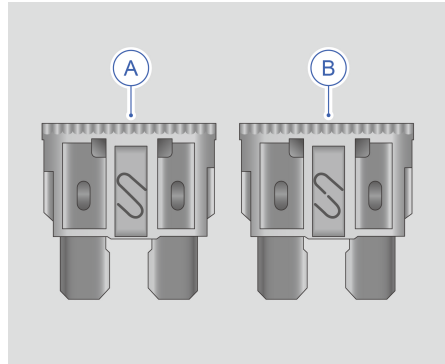



A - Fuse is intact

B - Fuse is blown

 Do not try to repair any blown fuse. Do not substitute any blown fuse with a fuse of different color or amperage. Otherwise, the electric system will get damaged or cause fire due to overload of wires. ◀

6. Replace with a new fuse of the same type and rating. If the fuse blows immediately after replacement, please contact PROTON e.MAS service outlet for maintenance as soon as possible.

 Always wear personal protective equipment and disconnect the high-voltage system if it is necessary to touch any high-voltage harnesses or components. Do not touch power battery components even after disconnecting the high-voltage system to avoid the risk of death by electric shock. ◀

 Color indicates the amperage of fuse. This amperage is also marked on fuse. ◀

 Any electric component in vehicle may be damaged by liquid splash. Be sure to secure the covers of all electrical components. ◀

## Fuse Box in Front Compartment

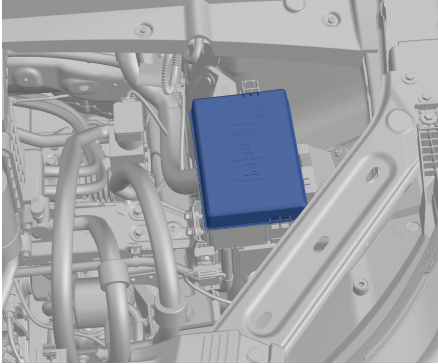

Open the front compartment cover, release the fuse box cover lock and remove the fuse box cover.

The related fuse information of the vehicle is posted inside the fuse box cover.

## Fuse Box at the Lower Instrument Panel of Driver Side

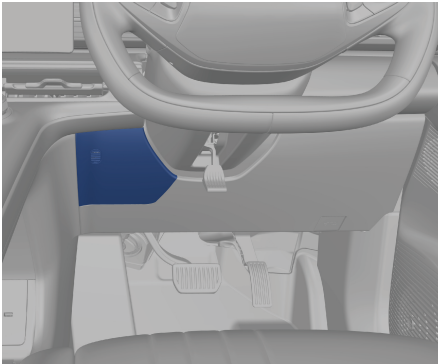

Open the internal fuse box cover which is located at the lower left of the instrument panel on the driver side. Remove the cover to see the fuses. The related fuse information label is posted on the inside cover.

## Fuse Box in Front Compartment

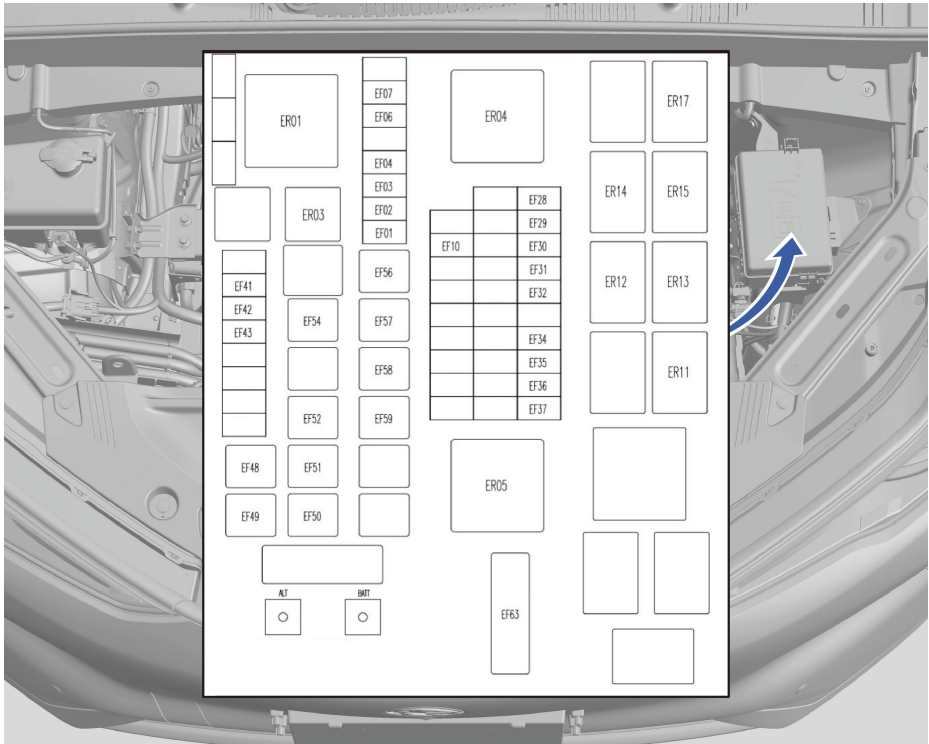

Fuse No.	Name	Ampere value	Description
EF01	BRAKE_SW	5A	-
EF02	BECM	10A	-
EF03	REAR_WIPER	15A	-
EF04	WASHER	20A	-
EF06	RLY_COIL	7.5A	-
EF07	HORN	15A	-
EF10	SW_HEAT*	15A	-
EF11	SMB*	25A	-
EF28	BCPF*	25A	-

Fuse No.	Name	Ampere value	Description
EF29	HCWP*	25A	-
EF30	EDCP*	25A	-
EF31	CPSR_RLY_FB	5A	-
EF32	EXV*/EEXV*/BEXV*	10A	-
EF34	TMCU_CPSR*	5A	-
EF35	ACCM/VALVE_Component	7.5A	-
EF36	AGS*	7.5A	-
EF37	PWM_FAN	5A	-
EF41	ZCUD_KL30_C	30A	-
EF42	EOP	20A	-
EF43	XCU	7.5A	-
EF48	BCM_UB_MR	60A	-
EF49	TMCU*	60A	-
EF50	BLOWER	40A	-
EF51	COMFORT_POWER*	30A	-
EF52	WWM	30A	-
EF54	REAR_DEFROST	40A	-
EF56	TRM_1*	40A	-
EF57	BCM_UB_VR	40A	-
EF58	ZCUD_KL30_A	30A	-
EF59	TRM_2*	25A	-
EF63	PWM_FAN	60A	-

## Fuse Box in Instrument Panel at Driver Side

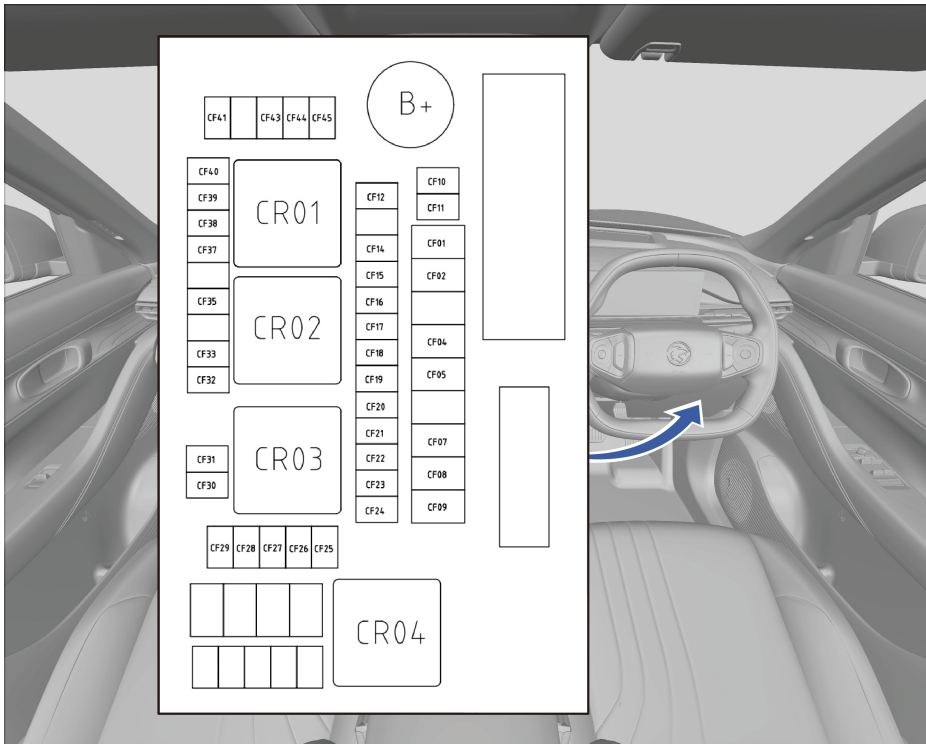

Fuse No.	Name	Ampere value	Description
CF01	ZCUD_KL30_B	30A	-
CF02	ZCUP_KL30_A	30A	-
CF04	AUD*	30A	-
CF05	PASSENGER_SEAT*	30A	-
CF07	POT*	30A	-
CF08	DRIVER_SEAT*	30A	-
CF09	ZCUD_KL3D_E*	30A	-
CF10	ZCUD_KL30_D	30A	-
CF11	SODL ODL DL* /SODR*	5A	-

Fuse No.	Name	Ampere value	Description
CF12	RLY_COIL	7.5A	-
CF14	ETC	10A	-
CF15	DHU	20A	-
CF16	ZCUP_KL30_B	30A	-
CF17	ZCUP_KL30_C	30A	-
CF18	OBD	10A	-
CF19	RLSM /ALCOHOL -DM	5A	-
CF20	TCAM *	5A	-
CF21	SWM	5A	-
CF22	CSD/DIS	10A	-
CF23	ZCUP_KL30D*	30A	-
CF24	ASDM*	5A	-
CF25	HDLP_ADJUST /SEAT_MASSAGE	7.5A	-
CF26	HUD*	5A	-
CF27	DMC */IRMM*	5A	-
CF28	SRM*	30A	-
CF29	WPS_15W	5A	-
CF30	SUS /OHC	7.5A	-
CF31	AMBIENT_LIGHT* /DVR*	7.5A	-
CF32	POWER_OUTLET	15A	-
CF33	FRONT /REAR_USB	15A	-
CF35	ETC_IG/ETCM	5A	-
CF37	IGN	5A	-
CF38	SRS	5A	-
CF39	SWM /PDCM	5A	-
CF40	APS	5A	-
CF41	IP_SW /DDS /IRRM	5A	-
CF43	DAB*	5A	-

Fuse No.	Name	Ampere value	Description
CF44	FSRL*/FSRR*	5A	-
CF45	ETCM /DVR	5A	-

**THIS PAGE IS INTENTIONALLY LEFT BLANK**

## Unlocking Door during Emergency

### Use Mechanical Key to Lock/Unlock

 When the smart key or the vehicle powers off, the mechanical key can be used to lock/unlock the driver door. ◀

#### Driver door

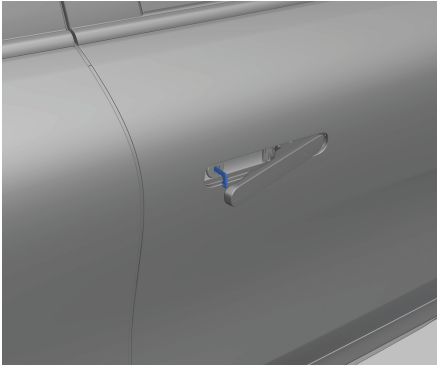

Press the right area of the driver door handle so that the left side of the door handle is tilted. And immediately hold the left side of the door handle, insert the mechanical key into the driver door lock. Rotate clockwise and the door is locked. Rotate counterclockwise and the door is unlocked.

#### Front door locked



1. Insert the mechanical key into the black knob of the door lock for rotation;
2. Take out the mechanical key and close the door to complete the locking.

#### Rear door locked

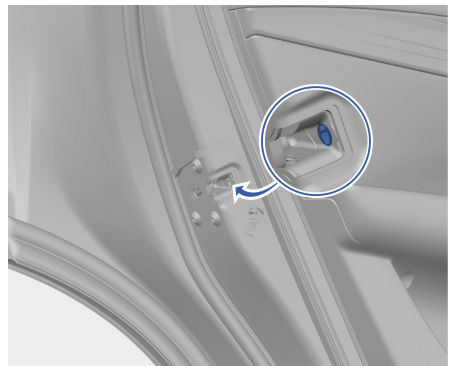

1. Insert the mechanical key into the black knob of the door lock for rotation;
2. Take out the mechanical key and close the door to complete the locking.

## Emergency Unlocking the Charging Gun

In case the AC charging gun cannot be pulled out, try one of the following options to unlock and then pull out the AC charging gun:

**Option 1:** Press the central control button on the driver door to unlock the vehicle and then pull out the AC charging gun;

**Option 2:** Press the unlock button of the intelligent key to unlock the vehicle and then pull out the AC charging gun;

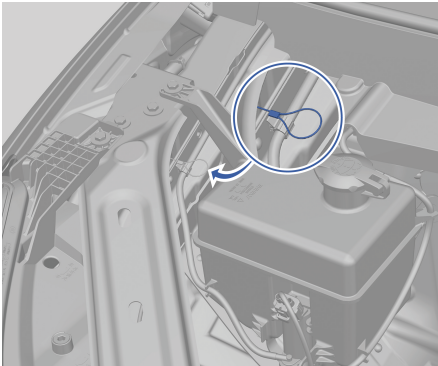

**Option 3:** Open the front compartment hood, pull out the emergency release charging port cable at the shown location in the front compartment to unlock and then pull out the AC charging gun.

 If the charging gun still cannot be pulled out, stop charging immediately and contact an PROTON e. MAS service outlet for countermeasure. ◀

## Towing

### Lifting and Towing Instruction

This vehicle is a pure electric vehicle with front wheel drive. You can use the following towing methods to transport this vehicle:

1. Flat-bed type: The vehicle is loaded on a towing truck.
2. Wheel-lifting type: The front wheels of the vehicle is lifted off the ground, and the rear wheels remain contact to the ground.



- If the flat-bed type of towing service is unavailable, the wheel-lifting type of towing can be used to tow the vehicle with the front wheels off ground.
- Both faulty vehicle and the tow truck shall turn on their hazard warning lamps. ◀

## Towing Ring

### Precautions When Using Towing Ring

- Make sure the towing ring is installed securely and reliably into the towing mounting hole.
- It is recommended to only mount and use certified traction bar or traction rope on the towing ring.
- Do not purposely use the towing ring to tow this vehicle up to the flat-bed truck.
- Do not purposely use the towing ring to rescue a trapped vehicle.

 When towing this vehicle using the towing ring, make sure to keep a safe distance from the towing vehicle.

- Do not use the towing chain/belt on the towing ring. The towing chain/belt may be broken, resulting in severe injury or death.
- Failure to follow the instructions when towing using towing ring may cause the parts to break, resulting in severe injury or death. ◀

 Use the towing ring for road rescue purpose only and shall not be used for other purposes.

- When using the towing ring, make sure to use a proper equipment that complies with the traffic regulations (such as a rigid towing bar or towing rope), to tow the vehicle on the ground to the nearest service outlet in a short distance.
- Do not use the towing ring to tow the vehicle on off-road or road with obstacles.
- When towing with a towing ring, both towing truck and the faulty vehicle must be on the same center line as far as

possible. Failure to follow the above instructions may result in vehicle damage.



### Installing Front Towing Ring

1. Take out the towing ring from the on-board tool kit in the trunk compartment;

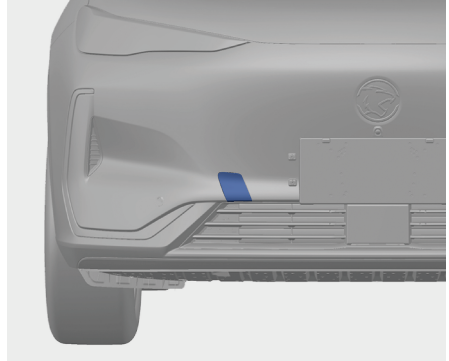

2. Open the cover plate of the mounting hole on the right side of front bumper;

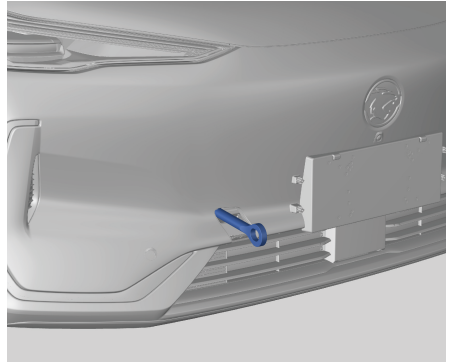

3. Install the towing ring into the towing mounting hole and tighten it to ensure that the towing ring is fully tightened.

### Installing Rear Towing Ring

1. Take out the towing ring from the on-board tool kit in the trunk;

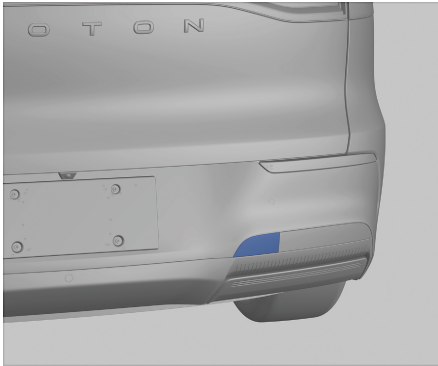

2. Take a flat tip screwdriver, wrap it in cloth and use it to pry off the cover plate of the towing mounting hole on the left side of the rear bumper;

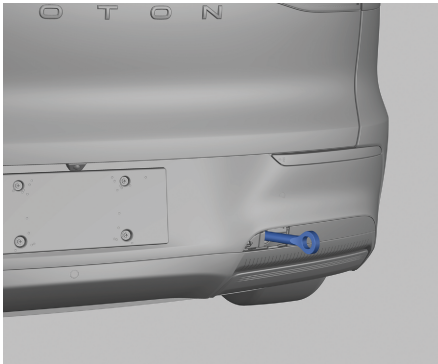

3. Install the towing ring into the mounting hole and tighten it with a tool to ensure that the towing ring is fully tightened.

 The towing ring should be placed back in the onboard tool kit when it is not in use. ◀

## Overheating of Drive Motor or Motor Controller

Overheating of the drive motor or motor controller actually refers to the condition when the coolant temperature becomes too high, which should be handled according to the following procedure:

1. Drive the vehicle safely off the road, stop and turn on the hazard warning lamp; then shift the gear into Park (P) position and press the electric parking brake (EPB) switch on the multimedia display. Turn off the air conditioning system.
2. Visually check whether there is any significant coolant leakage under the radiator, hose or vehicle. It is normal if there are water drops from the working air conditioner.
3. If the coolant leaks, stop using the vehicle immediately. Please contact authorised PROTON e.MAS service outlet for maintenance as soon as possible.
4. If no obvious coolant leak is found, check the coolant level in the coolant expansion tank. If it has dried up, fill the coolant expansion tank with coolant to about half of the tank while the vehicle is started.
5. If there is no coolant leakage and the coolant level in the expansion tank is normal, please contact PROTON e.MAS service outlet for maintenance as soon as possible.
6. When the coolant temperature is normal, recheck the coolant level in the expansion tank again. Add to half if necessary. Severe coolant loss indicates a leak in the system. It is

recommended to contact the PROTON e.MAS service outlet for maintenance.

7. After the vehicle is parked outside during hot day, the cooling fan usually operates automatically even for a long time. This is normal. The cooling fan will be automatically turned off after the temperature of drive motor or motor controller drops where the cooling fan does not need to work.



In order to avoid personal injury, the front compartment hood shall remain closed till there is no hot vapor. The overflow of vapor or coolant indicates that there is a high pressure. Keep away from the rotating cooling fan. ◀



When the warning message related to Power battery thermal failure appears in the meter instrument, stay away from the vehicle immediately and make an emergency call to avoid any accident and casualties. ◀

## Overheating of Drive Motor or Motor Controller

Overheating of the drive motor or motor controller actually refers to the condition when the coolant temperature becomes too high, which should be handled according to the following procedure:

1. Drive the vehicle safely off the road, stop and turn on the hazard warning lamp; then shift the gear into Park (P) position and press the electric parking brake (EPB) switch on the multimedia display. Turn off the air conditioning system.
2. Visually check whether there is any significant coolant leakage under the radiator, hose or vehicle. It is normal if there are water drops from the working air conditioner.
3. If the coolant leaks, stop using the vehicle immediately. Please contact authorised PROTON e.MAS service outlet for maintenance as soon as possible.
4. If no obvious coolant leak is found, check the coolant level in the coolant expansion tank. If it has dried up, fill the coolant expansion tank with coolant to about half of the tank while the vehicle is started.
5. If there is no coolant leakage and the coolant level in the expansion tank is normal, please contact PROTON e.MAS service outlet for maintenance as soon as possible.
6. When the coolant temperature is normal, recheck the coolant level in the expansion tank again. Add to half if necessary. Severe coolant loss indicates a leak in the system. It is

recommended to contact the PROTON e.MAS service outlet for maintenance.

7. After the vehicle is parked outside during hot day, the cooling fan usually operates automatically even for a long time. This is normal. The cooling fan will be automatically turned off after the temperature of drive motor or motor controller drops where the cooling fan does not need to work.



In order to avoid personal injury, the front compartment hood shall remain closed till there is no hot vapor. The overflow of vapor or coolant indicates that there is a high pressure. Keep away from the rotating cooling fan. ◀



When the warning message related to Power battery thermal failure appears in the meter instrument, stay away from the vehicle immediately and make an emergency call to avoid any accident and casualties. ◀

## In Case of Fire

In case of fire, immediately stop and shut down the vehicle. Quickly evacuate all occupants away from the vehicle. Make an emergency call to seek for help. To ensure personal safety, you can contact an authorised PROTON e. MAS service outlet and perform the following operations under the guidance of professionals:

1. If the power battery or high-voltage harness smokes and catches fire, spray with carbon dioxide or dry chemical fire extinguisher.
2. If the power battery catches fire, use a high-pressure water gun to extinguish the fire at a long distance.
3. If you accidentally inhaled thick smoke, please keep away from the scene and seek medical treatment as soon as possible.



- Power battery electrolyte leakage or damage can cause fire. If this happens, contact authorised PROTON e. MAS service outlet immediately for repair.
- Please do not touch any leaked electrolyte with hands. If skin or eyes accidentally come into contact with such electrolyte, please rinse with plenty of clean water immediately and seek medical advice immediately.
- If the vehicle catches fire, please leave the vehicle immediately. ◀

## Getting Vehicle Out of Trap

When the vehicle is stuck in snow, mud pit, sands or other similar conditions, please perform following steps:

1. Observe the front and rear areas of the vehicle and make sure that there are no people or obstacles.
2. Turn the steering wheel left/right to grind the area around the front wheels.
3. Engage the forward or reverse gear to move the vehicle forward and backward slowly.
4. If you still cannot get out of the situation after many attempts, seek professional trailer services.



When you make forward and backward movement in the process of driving the vehicle out of trap, the vehicle may suddenly rush forward or backward. The driver must keep alert at all times to avoid any casualties. ◀

**THIS PAGE IS INTENTIONALLY LEFT BLANK**

## Exterior Identification Information

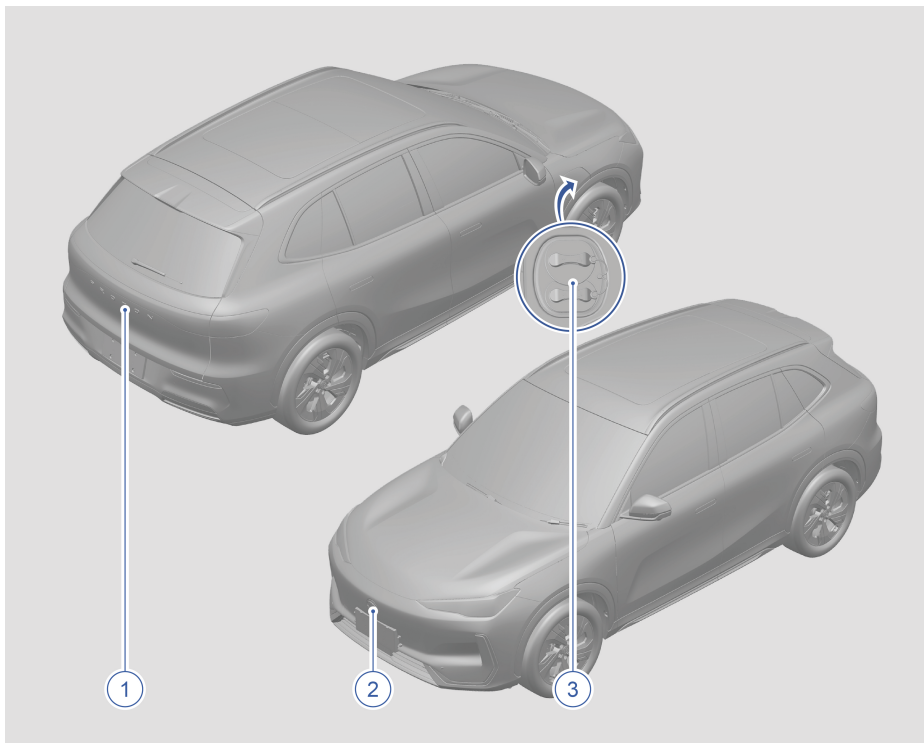

1. Manufacturer identification
2. Vehicle identification

3. Charging port

## Powertrain Information

### Introduction of Power System

The power system includes: power battery, high-voltage charging and distribution system, and electric drive system.

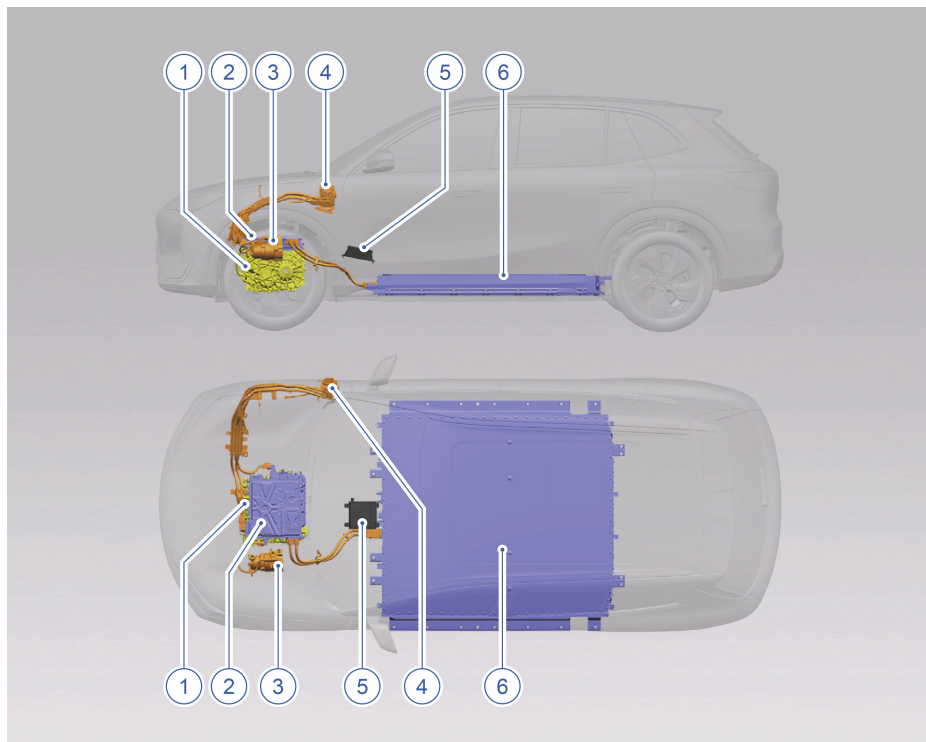

- |  |                        |
|--|------------------------|
| 1. Electric drive system                         | 4. Charging port       |
| 2. High-voltage charging and distribution system | 5. Low-voltage battery |
| 3. Compressor                                    | 6. Power battery       |

## **Power Battery**

The power battery pack integrates multiple cells, relays, fuses and other components, and the power battery can be charged repeatedly.

## **High-voltage Charging and Distribution System**





High-voltage charging system: generally composed of on-board charger, DC-DC converter, power battery management system, etc.

High-voltage distribution system: a system in electric vehicles responsible for distributing electrical energy from battery packs to various electrical equipment and motors. Its main components include DC bus, AC/DC combined charging socket harness assembly, A/C high-voltage harness assembly, etc. All high-voltage cables are orange in color. Do not touch these cables and components when the vehicle is powered on. Wrap the high-voltage cable connectors with insulating tape immediately after they are pulled out.

## **Drive Motor**

The vehicle adopts a permanent magnet synchronous drive motor and the motor rotor adopts permanent magnets. The rotating magnetic field and stator coil work together to generate torque. The torque is controlled by the motor control unit. The motor control unit dissipates heat from the electronic power devices by means of coolant.

## Safety Sign Information

No.	Name	Pattern	Meaning
1	High-voltage warning sign		Danger! Do not touch high-voltage components.
2	High-voltage components warning sign		Danger! Do not touch high-voltage components.
3	Power battery label (Illustration)		Basic information of power battery system
4	High-voltage harness		High-voltage harness color: orange

## Emergency Device Information

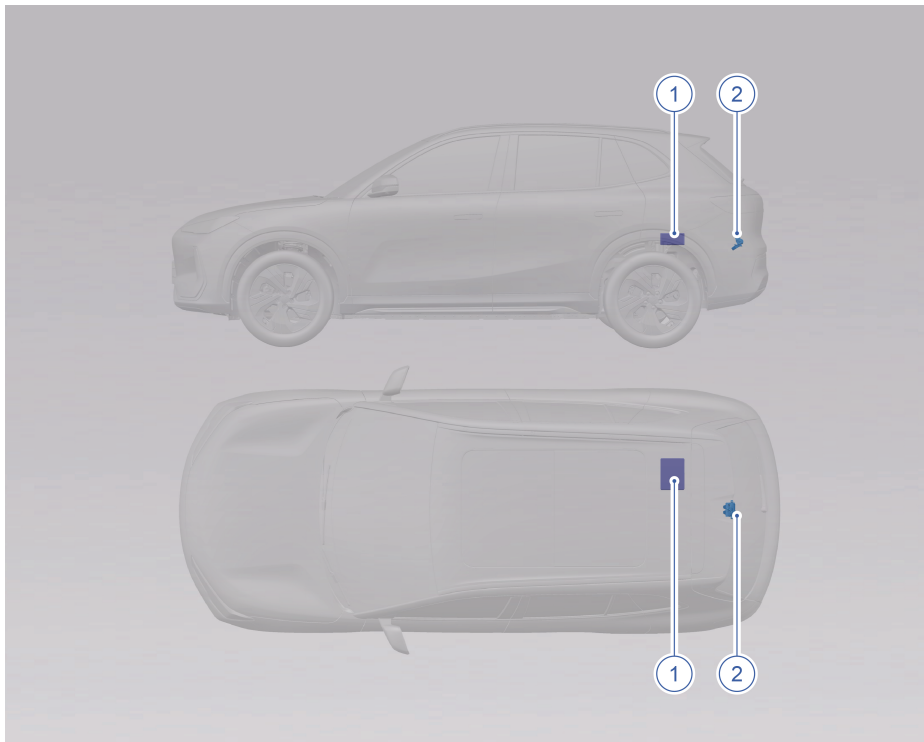

1. Tyre repair kit

2. Tailgate lock

### Parking

Depress the brake pedal, stop the vehicle smoothly and press P button to shift the gear to Park (P) position; the electric parking brake will engage. Switch the vehicle power mode to OFF position.

### Emergency Unlocking of Tailgate

1. Fully fold the rear seatback;
2. Access the trunk interior directly from the rear door and locate the cover for the trunk emergency opening device on the trunk interior trim panel;

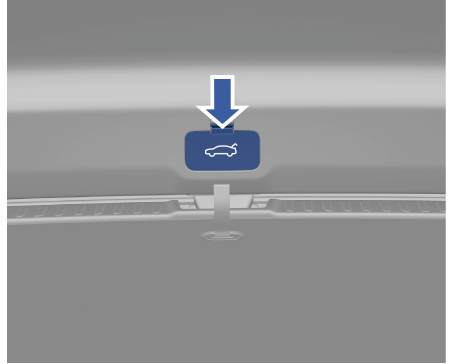

3. Lift the trunk emergency opening device cover;

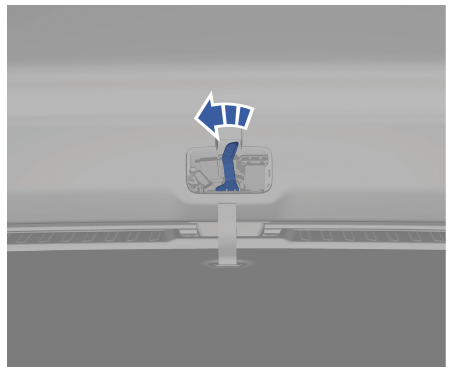

4. Toggle the trunk emergency opening switch to the left to open the trunk.

## High-voltage Cutoff Method

### Repair of High Voltage Cutoff During Maintenance

1. Shift the gear in Park (P), with the vehicle in a non high-voltage state and the vehicle stationary. Open the front compartment hood, pull out the red 10A BECM fuse, close the doors, press the smart key lock button/car search button and put the vehicle power mode to OFF position. Wait at least 5 minutes to ensure the high-voltage system is completely powered off;

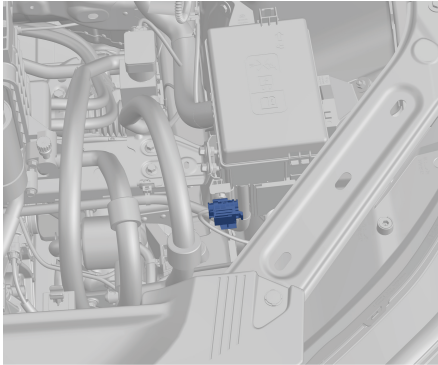

2. Disconnect the low-voltage repair switch in the front compartment;

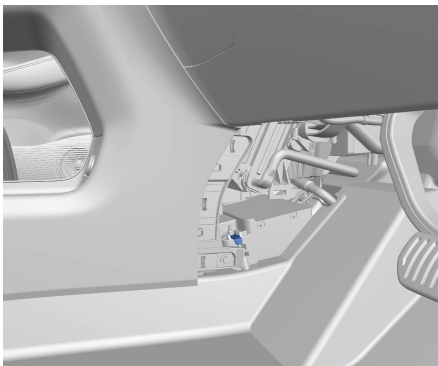

3. Open the driver door and remove the cover under the front centre console as shown. Disconnect the negative cable from the negative terminal of the low-voltage battery.

 Always wear personal protective equipment and disconnect the high-voltage system if it is necessary to touch any high-voltage harnesses or components. Do not touch power battery components even after disconnecting the high-voltage system to avoid the risk of death by electric shock. ◀

### Emergency High-voltage Cut-off During Rescue

During rescue operations, in case there is a voltage leakage or an uncertainty whether the high-voltage has been disconnected, use scissors or diagonal pliers to cut the harness to realize the emergency cutoff of the high voltage power and avoid secondary injuries to the trapped or rescued personnel.

#### Cutting Point in the Front Compartment

1. Open the front compartment hood;

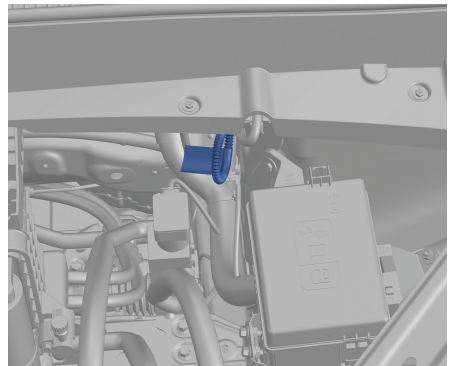

2. Use scissors or diagonal pliers to cut the harness at the shown locations to

realize the emergency cutoff of the high voltage power.

### Cutting Point in the Trunk Compartment

1. Open the tailgate and pry off the right trim panel of the trunk compartment as ;

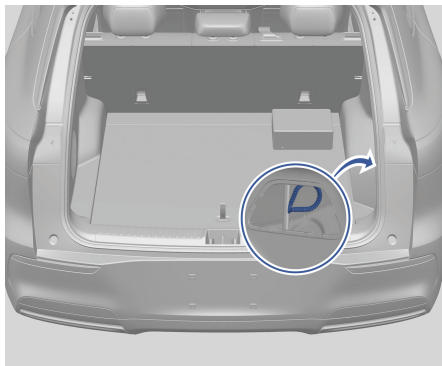











2. Use scissors or diagonal pliers to cut the harness at the shown location to achieve emergency cutoff of high voltage.

## Protective Equipment

The following protective equipment should be properly maintained and used when touching or handling high-voltage system:

- Wear safety glasses when handling high-voltage system.
- Wear 1000v insulated gloves when touching high-voltage components.
- Use insulated tools when handling high-voltage system.
- Prepare insulated protective hooks. Fire extinguisher suitable for lithium battery.
- Do not work alone, it is necessary to follow the principle of two people. If an accident occurs, assistance may be needed.

Name	Picture	Note
Acid and alkali resistant gloves		Used in case of lithium battery electrolyte leakage
Insulated protective hook		Used in case of electric shock
Dry powder extinguisher		Used to extinguish fire
Fire blanket		
High-voltage insulated gloves		Used to prevent high-voltage electric shock

Name	Picture	Note
Insulated cap		
Safety glass		Used to prevent high-voltage electric shock
Insulated shoe		
Insulating tape		Cover damaged harnesses to provide protection and prevent electric shock. Tape should be wrapped around all exposed or damaged harnesses
Insulating tool		Used for operating high-voltage system components

## Jump Starting

**i** If the vehicle cannot be started due to weak or flat low-voltage battery, a jump start method (using another vehicle and a jumper cable) can be performed to start the vehicle. ◀

**▶** Do not intend to start the vehicle by pushing or pulling; use only a low-voltage battery for jump start. ◀

### Method 1: Direct to the low-voltage battery

The following method can only be performed by certified well trained technician. If you are not qualified to perform these procedures, please contact your authorised PROTON e.MAS service outlet for assistance whenever possible. ◀

1. Turn the vehicle power mode to OFF position. Turn off all lamps and electric accessories, except turning on the hazard warning lamp (if necessary);
2. Remove the trim cover under the front centre console of instrument panel and locate the low-voltage battery;

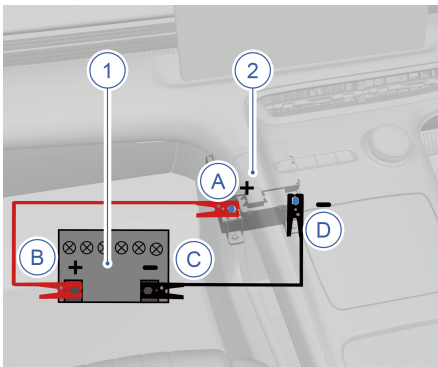

1 - Low-voltage battery with power

- 2 - Low-voltage battery with weak or flat battery
3. Connect one end of the red positive jumper cable to the positive (+) terminal (A) of the low-voltage battery with weak or flat battery;
4. Connect another end of the red positive jumper cable to the positive (+) terminal (B) of the low-voltage battery with power;
5. Connect one end of the black negative jumper cable to the negative (-) terminal (C) of the low-voltage battery with power;
6. Connect another end of the black negative jumper cable to the negative (-) terminal (D) of the low-voltage battery with weak or flat battery;
7. Try to turn on/start the vehicle that has weak or flat battery. If it doesn't start after several attempts, contact authorised PROTON e.MAS service outlet for assistance.

### Method 2: From the jump start point in front compartment fuse box

1. Turn the vehicle power mode to OFF position. Turn off all lamps and electric accessories, except hazard warning lamp (if necessary);

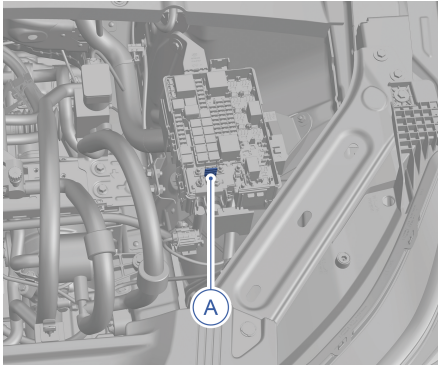

A – Jump start point (in front compartment fuse box)

A

2. Connect one end of the red positive (+) jumper cable to the positive (+) jump start point (A) in the front compartment fuse box of vehicle with weak or flat battery;

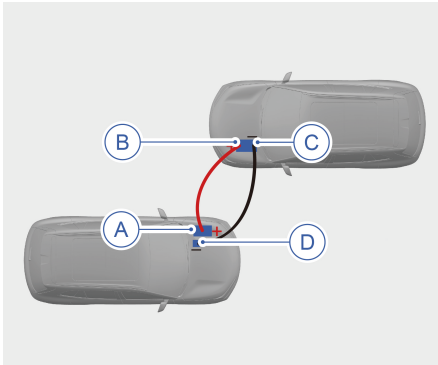

3. Connect another end of the red positive jumper cable to positive (+) terminal (B) of the low-voltage battery of vehicle with good battery.

Do not let another end of the red positive (+) jumper cable contacts other metal parts.

4. Connect one end of the black negative (-) jumper cable to the negative (-) terminal (C) of the low-voltage battery of vehicle with good battery.

Do not let another end touch anything before proceeding to next step. ◀

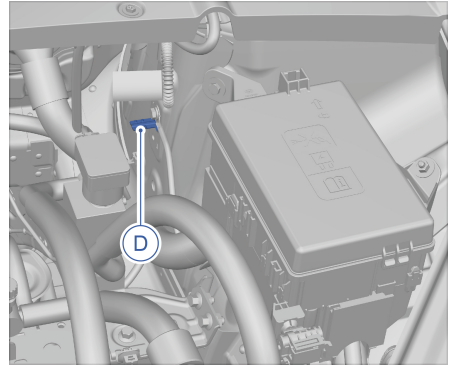

D – Ground point (on vehicle body)

5. Connect another end of the black negative (-) jumper cable to the ground point (D) on the body of the vehicle with good battery as shown above. Confirm that the connection has been securely connected to prevent sparks when attempting to start;
6. Start the vehicle that has good battery and keep the vehicle idle for at least four minutes;
7. Try to start the vehicle that has weak or flat battery. If it fails to start with a few attempts, the vehicle will likely need to be repaired.

If the jumper cable is connected or removed in wrong sequence, a short circuit may occur and the vehicle may be damaged. Repair caused thereby is not covered by warranty. Therefore, it is necessary to connect or remove jumper cable in correct

sequence, and make sure the ends of these cables do not touch each other or contact other metal. ◀

Once complete jump starting, to disconnect the jumper cables between the two vehicles, it is required to:

1. Disconnect the black negative (-) jumper cable on vehicle whose battery is weak or flat;
2. Disconnect the black negative (-) jumper cable on vehicle whose battery is good;
3. Disconnect the red positive (+) jumper cable on vehicle whose battery is good;
4. Disconnect the red positive (+) jumper cable on vehicle whose battery is weak or flat.



- Cooling fan and other operating components of the drive motor can cause personal injury. Avoid touching the cooling fan or drive motor with hands, clothing and tools when the drive motor is running or not running.
  - Gases may escape from the low-voltage battery during charging or jump starting. There is a risk of explosion at this time. Be sure to keep low-voltage battery away from sparks, open flames, and other flammable objects.
  - The use of open fire near low-voltage battery may explode the gases in battery and cause severe casualties. Low-voltage battery fluid is corrosive and can cause serious damage to eyes and skin. If accidentally in contact, immediately rinse with plenty of clean water and seek immediate medical attention.
- When connecting and removing jumper cables, avoid twining the jumper cables with fans, belts, etc.
  - Ensure that each cable is properly connected and the ends of the jumper cables are kept at a distance from each other to avoid contact between positive and negative terminals. Failure to follow the above steps will result in repair that is not covered by the warranty.
  - Do not reverse the polarity between positive and negative terminals when connecting the jumper cable. Otherwise, it may cause high-voltage system failure and the vehicle can not start.
  - If the vehicle fails to start after several attempts or the low-voltage battery keeps running out of charge, contact an authorised PROTON e.MAS service outlet for repair. ◀

## Cutting the Vehicle Body



Do not cut, expand or puncture areas related to high-voltage system and power battery.

Personal protective equipment must be worn at all time when removing components.

Otherwise, serious personal injury or death may occur. ◀

### Airbag Components

Cutting, expanding or puncturing airbag components without deployment is strictly forbidden, as an accidentally deployed airbag could result in serious personal injury or death. However, cutting is permitted under the following conditions:

- The front airbag, side airbag and side curtain airbag have deployed.
- The negative cable of low-voltage battery has been disconnected for more than 3 minutes and the high-voltage system has been turned off.

The locations of airbags and impact sensors are shown below:

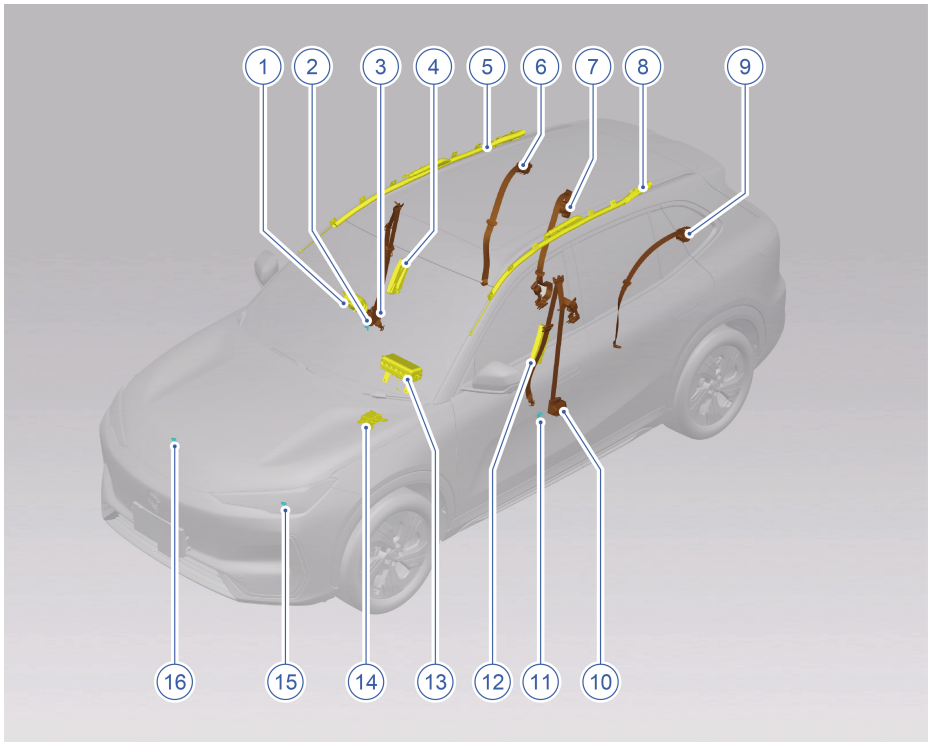

- |                                    |                                    |
|------------------------------------|------------------------------------|
| 1. Driver airbag                   | 9. Rear left seat belt retractor   |
| 2. Right side impact sensor        | 10. Left front seat belt retractor |
| 3. Right front seat belt retractor | 11. Left side impact sensor        |

- |                                    |                               |
|------------------------------------|-------------------------------|
| 4. Right side airbag               | 12. Left side airbag          |
| 5. Right curtain airbag            | 13. Front passenger airbag    |
| 6. Rear right seat belt retractor  | 14. Airbag controller unit    |
| 7. Rear middle seat belt retractor | 15. Left front impact sensor  |
| 8. Left curtain airbag             | 16. Right front impact sensor |

### **High-Voltage System and No Cutting Components**

The yellow shaded areas shown in next figure are high-voltage components and harnesses that can only be cut when the high-voltage system is turned off.

The orange shaded areas shown in next figure are "no-cutting areas". Cutting, expanding, puncturing or crushing in these areas is strictly forbidden, otherwise accidents such as high-voltage electric shock, fire and explosion will occur, which will result in serious personal injury or death.

The black shaded area shown in next figure is the low-voltage battery, and cutting it is strictly forbidden.

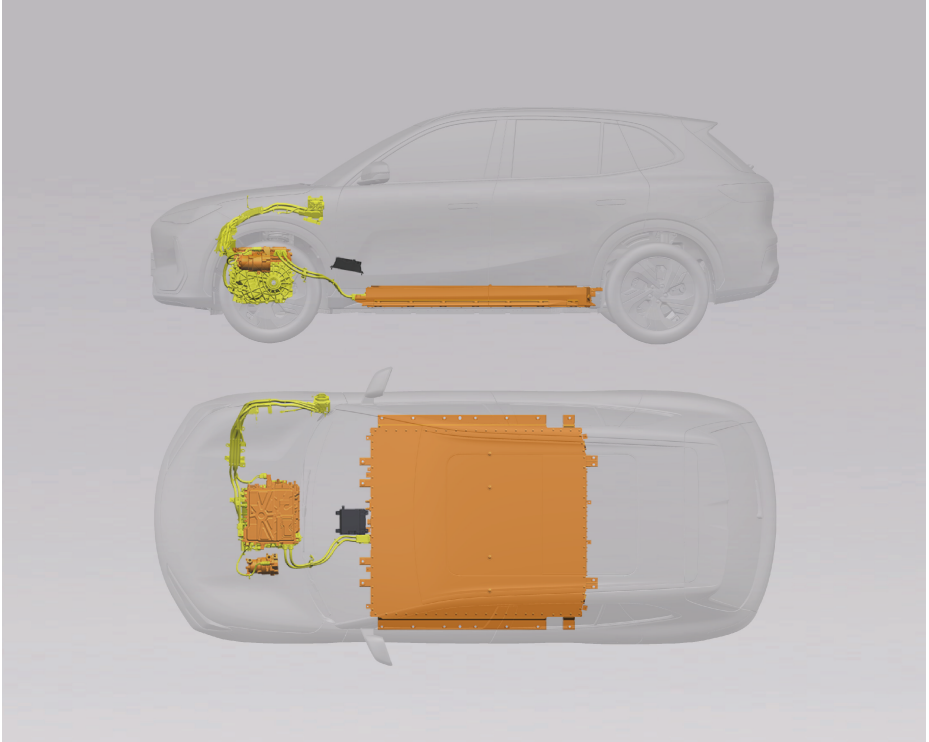



- Always use appropriate tools such as hydraulic cutters and wear appropriate personal protective equipment when cutting. Failure to follow these instructions may result in serious personal injury or death.
- All high-voltage components are energized by default, regardless of whether the high-voltage cutoff procedure is performed! Cutting, expanding, puncturing, crushing or touching high-voltage components may result in serious personal injury or death. ◀

## In Case Submerged in a Flood



The extent of damage to a waterlogged vehicle may not be obvious.

Protective tools must be provided when handling a waterlogged vehicle, otherwise, electric shock may cause injury or death. ◀



- Before touching any high-voltage system components while the vehicle is submerged in a water, make sure the rescue personnel wears the protective tools to prevent electric shock.
- The high-voltage system of a waterlogged vehicle must be disconnected before handling the vehicle. The vehicle must be completely dried after it has been removed from the waterlogged area to prevent injury from electrical leakage. ◀

## Rescuing the Vehicle in Case of Fire



- In case of fire, do not touch any part of the vehicle as it is fully energized. It is necessary to wear personal protective equipment, including self-contained air breathing apparatus.
- In case the power battery caught fire, quickly stay away from the vehicle at a safe distance. Use plenty of water or a water-based fire extinguisher to cool the power battery.
- High-voltage components may be energized during a fire! Cutting, crushing or touching high-voltage components may result in serious personal injury or death.
- If there are occupants in the vehicle during rescue efforts, be sure to help them escape by pulling the door handle to see if the door can be opened. If the door cannot be opened, a sharp, hard object can be used to strike the corners of the door glass to help the occupants escape by breaking the window. ◀



- Do not use fire extinguishers containing electrical substances to extinguish fires, as this may result in electric shocks or other accidents.
- High-voltage components on fire must be extinguished with a water-based fire extinguisher suitable for lithium battery.
- When the vehicle is on fire, quickly leave and stay away from the vehicle at a safe distance; make an emergency call and

notify the rescue personnel that the vehicle on fire is an electric vehicle equipped with high-voltage components.



When a fire occurs, for personal safety, the following operations can be carried out if conditions permit:

- If the harness smokes and catches fire, spray with carbon dioxide or dry powder extinguisher.
- If smoke is emitted from the power battery, it should be considered that the power battery is heating up. Please use a high-pressure water gun to extinguish the fire from a distance.
- If a person accidentally inhaled thick smoke, please move the person away from the scene and seek medical treatment as soon as possible.
- After all flames and smoke have completely subsided, use a thermal imaging camera to actively measure the temperature change trend of the power battery. There should be completely no fire, nor smoke or heat in the power battery for at least one hour before the vehicle can be moved. The power battery must be completely cooled before taking away the vehicle from the accident scene. Remind the transporter that there is always a risk of the power battery could re-ignite.
- When extinguishing residual fires in the latter stages of fire fighting, it is important to make sure that the power battery is completely cooled in order to prevent it from re-ignition. The power battery can re-ignite when it is close to an ignition source. To prevent possible electric

shock and personal injury, do not damage the power battery housing.

## Evacuating Occupants during Emergency

### Evacuating Occupants After Doors are Unlocked

If life is endangered and need to escape, do the following to escape from the scene as quick as possible:

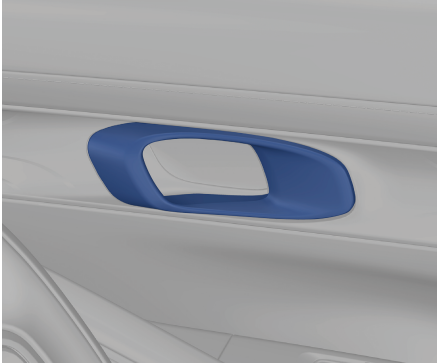

When the doors are unlocked, the doors can be opened by pulling the inside door handles of the vehicle.



- Each of the remaining three doors can be unlocked and opened by pulling the interior handles.
- If the rear door can not be opened, possibly the child lock is locked. Open the rear doors from outside of the vehicle or lower down the window glass to reach and pull the inside door handle from outside to open the rear doors.
- When all doors cannot be opened or is locked, use a sharp and hard object to strike the corners of the door glass to break the window and escape. ◀

## Power Battery Damage and Fluid Leakage



The power battery contains electrolyte. To prevent accidental injury, be sure to observe the following precautions:

- In case of accidental inhalation of electrolyte or fumes, it may cause respiratory sensitization. Inhalation of vapors may cause sensitization of the upper respiratory tract and lung, it is necessary to breathe fresh air and seek medical attention immediately.
- Skin contact with electrolyte or fumes may cause skin sensitization and/or chemical burns. It is necessary to change contaminated clothing and wash skin with soap and water immediately. If chemical burns or persistent irritation occurs, seek medical attention immediately.
- Prolonged skin contact with electrolyte may cause localized inflammation through skin absorption.
- Eye contact with electrolyte may cause severe sensitization and chemical burns. It is necessary to open the upper and lower eyelids and flush the eyes with water immediately for more than 15 minutes, then seek medical attention immediately.
- Electrolyte is volatile and flammable, so pay attention to fire prevention and ventilation.
- In the event of an electrolyte leakage, wear appropriate personal protective equipment and clean up any spilled electrolyte with a dry cloth. Ensure adequate ventilation in this area. ◀

If electrolyte leakage or any problem or damage to the power battery housing is observed, rescue personnel must wear personal protective equipment and must not touch the electrolyte with their hands. Lime powder can be used to dilute and neutralize the electrolyte, and water cannot be used for dilution. The neutralization process helps stabilize the thermal state of the power battery, but does not discharge the power battery.

## Evacuating the Vehicle From Accident Scene

### Towing Mode

#### Turning on the Towing Mode

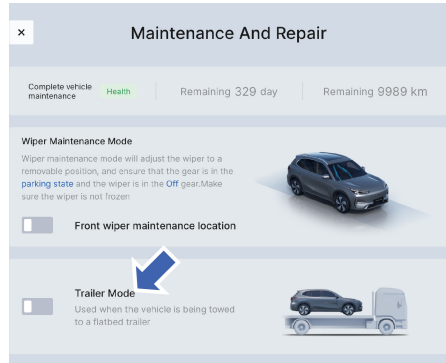

Click the following on the multimedia display in sequence: Vehicle Settings → My Car → Maintenance and Repair, and turn on the towing mode in the interface.

#### Turning off the Towing Mode

Click the following on the multimedia display in sequence: Vehicle Settings → My Car → Maintenance and Repair, and turn off the towing mode in the interface.



- If the status indicator of the electric parking brake (EPB) system lights up after the towing mode is on, it indicates that the electric parking brake system has a failure. It is recommended to contact authorised PROTON e.MAS service outlet for maintenance.
- If the electronic parking brake (EPB) system does not engage, the rear wheels should be locked to prevent the vehicle from moving, when necessary.

- Before turning on the towing mode, make sure the vehicle is in a stable condition to avoid accidents caused by slipping. It is necessary to shift the gear to Park (P) position and press the brake pedal to start the towing mode. After the towing has completed, exit the towing mode in time and reset the vehicle by locking or restarting it to ensure that the vehicle is in normal condition. ◀

After an accident, if the vehicle cannot start normally, evacuate the vehicle from the scene as shown in the next figure.

- If it is not possible to tow the vehicle normally with a flat-bed towing truck, the vehicle can be towed urgently to a safe area by rigid connection and wait for rescue.
- Avoid long-distance towing when adopting rigid towing and the towing speed should be no more than 5 km/hour. Only tow the vehicle from the scene when it is confirmed that there is no safety risk. If the vehicle battery pack is deformed, leaking, smoking, etc., safety risk should be prevented first. ◀

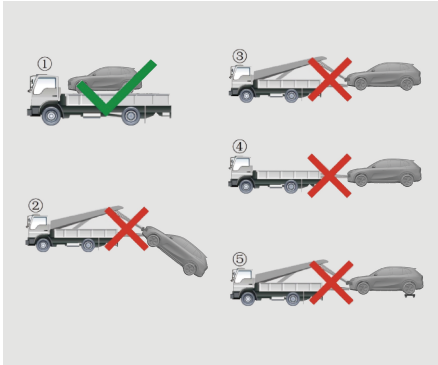

Vehicle towing precautions are as follows:

- Towing method of flat-bed towing truck (with all wheels off the ground) should be used. Avoid using the towing methods as shown in figure □□□□.
- Put the vehicle power mode in OFF position before towing, turn on the hazard warning lamp, close all doors and lock the doors using the emergency mechanical key. During towing, do not let anybody stay in the vehicle.



## Vehicle Storage

If the vehicle needs to be stored or left unattended for a long period of time, the high-voltage system must be disconnected. Please refer to “High-Voltage Cutoff Method” topic in this manual. When necessary, stick high-voltage warning labels and place high-voltage warning signs on the vehicle to remind pedestrians that touching the vehicle is strictly forbidden and failure to do so could result in serious personal injury or death.



Strictly observe the following conditions when storing the vehicle:

- Do not park the vehicle in places with poor ventilation and high temperature environment.
- Vehicles should be placed in a clean and dry environment with evacuation routes kept clear.
- Do not remove the power battery assembly at will, or knock it with any heavy objects, or puncture any part of it with a sharp object; Do not use a metal to connect the positive and negative poles of the power battery assembly directly; avoid contact with corrosive objects to prevent external short circuit in the power battery.
- If the vehicle was waterlogged, or caught fire, or collided, the vehicle should be parked in an open area due to the possibility of re-ignition; at least 15 m around the vehicle should also be cleared up and gazetted as danger zone to prevent any person from getting near the vehicle.



**THIS PAGE IS INTENTIONALLY LEFT BLANK**

## Vehicle Identification Number

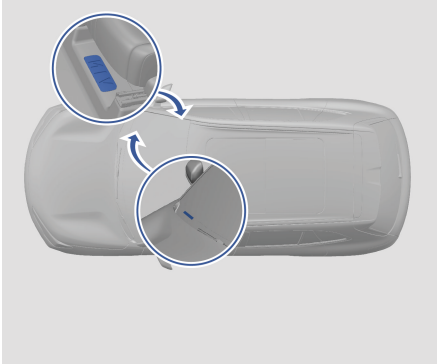

The vehicle identification number (VIN) is engraved on the body cross member under the driver seat. Move the seat backward to the endmost position and lift up the cover to view the VIN.

There is also a VIN on the body bracket in the left lower corner of the windshield, which can be seen through the windshield.

 The VIN is always required when contacting an authorised PROTON e.MAS service outlet. If the VIN on the vehicle body is damaged, contact an authorised PROTON e.MAS service outlet in time. ◀

You can use the PROTON diagnostic apparatus through an authorised PROTON e.MAS service outlet to read the vehicle identification code. Specific steps are as follows:

1. The vehicle power mode is switched to OFF position;
2. Connect the PROTON vehicle diagnostic instrument to the OBD diagnostic interface.
3. Activate the diagnosing program. Start the vehicle, and touch “Welcome”;

4. Enter into the control module to read the VIN.

 Only an authorised PROTON e.MAS service outlet can perform the VIN reading as per above method. Otherwise, it may cause damage to the vehicle. ◀

## VIN Label

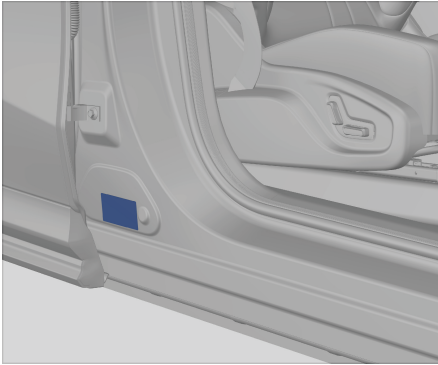

This label contains VIN and other related information.

## Drive Motor Code

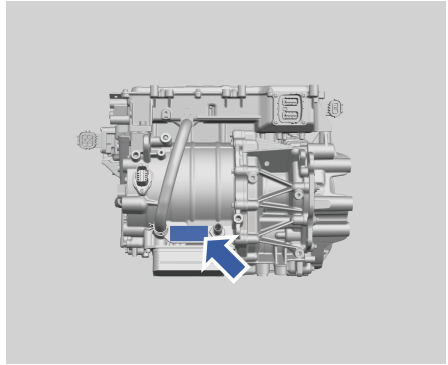

The drive motor code/identification is located in the middle of the electric drive system.

## Dimension

Item	Unit	Parameter
Vehicle length	mm	4615
Vehicle width	mm	1901
Vehicle height	mm	1670
Front wheel track	mm	1630/1620
Rear wheel track	mm	1621/1611
Wheel base	mm	2750

## Weight

Item	Unit	Parameter
Curb weight	kg	1662/1765
Front curb weight	kg	894/957
Rear curb weight	kg	768/808
Maximum allowed total weight	kg	2150/2267
Front maximum axle load	kg	1040/1115
Rear maximum axle load	kg	1110/1152

Note : The above weight are based on information available at the time of published. All value declared has a tolerance of 1%.

## Performance

Item	Unit	Parameter
Drive type	-	Front drive
Maximum vehicle speed	km/h	175
Maximum gradeability	%	30

## Power Battery

Item	Unit	Parameter (46.95 kWh)	Parameter (58.33 kWh)
Type	-	LFP battery	LFP battery
Rated voltage of power battery system	V	378	376
Rated capacity of power battery system	Ah	131	160

## Drive Motor Specification

Item	Unit	Type 1	Type 2
Model	-	TZ184XY101	TZ184XY102
Type	-	Permanent magnet synchronous motor	Permanent magnet synchronous motor
Rated Power	kW	70	70
Maximum Net Power	kW	160	100
Maximum Power Speed	r/min	3,500 ~ 16,000	3,500 ~ 16,000
Rated Torque	N·m	130	130
Maximum Net Torque	N·m	320	320
Rated Speed	r/min	5,150	5,150
Maximum Motor Rotation	r/min	16,500	16,500

## Wheel Alignment Specification

Item	Parameters (no load)
Camber of front wheel	-23'±39' (left-and-right difference ≤39')
Camber of rear wheel	-25'±43.8' (left-and-right difference ≤43.8')

Item	Parameters (no load)
Kingpin inclination	13°5'±30' (left-and-right difference ≤30')
Caster	5°48'±30' (left-and-right difference ≤30')
Front wheel toe-in (both sides)	12'±6' (left-and-right difference ≤6')
Rear wheel toe-in (both sides)	12'±6' (left-and-right difference ≤6')

## Recommended Fluid and Capacity

Item	Specification	Capacity
Brake fluid	DOT4	0.75 L
Drive motor and power battery coolant	Ethylene glycol-type coolant	11.5 L

**THIS PAGE IS INTENTIONALLY LEFT BLANK**

# Index

360 Camera ..... 165

## A

A/C Settings ..... 174  
Active Lane Change Assist  
(ALCA) ..... 138  
Adaptive Cruise Control System  
(ACC) ..... 121  
Adjustment of Door Mirror ..... 63  
Adjustment of Driver Seat ..... 57  
Adjustment of Front Passenger  
Seat ..... 95  
Adjustment of Front Seat Headrest ..... 97  
Adjustment of Interior Rearview  
Mirror ..... 65  
Adjustment of Rear Seat ..... 96  
Adjustment of Rear Seat Headrest .... 98  
Adjustment of Steering Wheel ..... 59  
Air Vent ..... 173  
Anti Rolling Program (ARP) ..... 111  
Anti-lock Braking System (ABS) ..... 109  
Anti-theft System ..... 50  
Automatic High Beam Control  
(AHBC) System ..... 78  
Automatic Locking and Unlocking .... 44

## B

Brake Assist (BA) ..... 111  
Brake Fluid ..... 181

## C

Car Search Mode ..... 39  
Central Locking and Unlocking ..... 44  
Child Safety Lock ..... 38  
Collision Mitigation Support Front  
System (CMSF) ..... 145  
Coolant ..... 180  
Cutting the Vehicle Body ..... 224

## D

Deployment of Airbag ..... 24  
Dimension ..... 237  
Door Handle ..... 45  
Drive Mode ..... 105  
Drive Motor Code ..... 236  
Drive Motor Specification ..... 238  
Driver Easy Access\* ..... 45  
Driving Instructions ..... 101

## E

Electric Power Steering (EPS) ..... 115  
Electronic Braking-force  
Distribution (EBD) ..... 109  
Electronic Stability Control System  
(ESC) ..... 110  
Emergency Device Information ..... 215  
Emergency Unlocking of Trunk ..... 216  
Emergency Unlocking the  
Charging Gun ..... 204  
Energy Recovery ..... 107  
Evacuating Occupants during  
Emergency ..... 230  
Evacuating the Vehicle From  
Accident Scene ..... 231  
Evasive Manoeuvre Assist (EMA) ... 152  
Event Data Recorder (EDR)\* ..... 9  
Exterior Cleaning ..... 190  
Exterior Identification Information ..... 211  
Exterior Lighting ..... 81

## F

Fault of Headlamps ..... 194  
Folding and unfolding of Door  
Mirrors ..... 63  
Foreword ..... 1  
Front A/C Control System ..... 169  
Front Compartment Hood ..... 178  
Front Cross Traffic Alert (FCTA) ..... 150  
Front Seat Ventilation\* ..... 96

Front Storage Compartment .....	51
Fuse Box in Front Compartment .....	197
Fuse Box in Instrument Panel at Driver Side .....	199

## G

Gear Shift Lever .....	104
Getting Vehicle Out of Trap .....	209
Graphical Information .....	9

## H

Hazard Warning (HAZ) .....	114
Hazard Warning Lamp .....	81
Head Up Display (HUD)* .....	99
High-voltage Cutoff Method .....	217
Hill Descent Control (HDC) .....	113
Hill-start Assist Control (HAC) .....	112
Horn .....	59

## I

In Case of Fire .....	208
In Case Submerged in a Flood .....	228
Installation of Child Restraint System .....	32
Intelligent Cruise Control System (ICC) .....	129
Intelligent Key .....	39
Intelligent Knob .....	94
Interior Cleaning .....	191
Interior Lighting .....	79
Introduction to The Intelligent Driving System .....	119

## J

Jump Starting .....	221
---------------------	-----

## L

Lane Keep Assist System (LKA) .....	142
Leaving the Vehicle Without Power-off .....	105
Light Combination Switch .....	75

Low-voltage Battery .....	184
---------------------------	-----

## M

Maintenance .....	177
-------------------	-----

## N

Notes to Users .....	5
----------------------	---

## O

Opening and Closing the Tailgate .....	46
Overheating of Drive Motor or Motor Controller .....	206–207
Overview of Airbag .....	20
Overview of Exterior .....	11
Overview of Front Compartment .....	13
Overview of Interior .....	12
Overview of Meter Instrument .....	83
Overview of Seat Belt .....	15

## P

Panoramic Sunroof* .....	69
Park Assist System (PAS) .....	163
Parking .....	216
Performance .....	237
Positions of Airbags .....	21
Power Battery .....	186
Power Battery Damage and Fluid Leakage .....	230
Power Battery Specification .....	238
Power Window .....	66
Powertrain Information .....	212
Prompt Message .....	8
Protective Equipment .....	219

## R

Rear Side Radar Assist System (RSRS) .....	157
Rear Storage Compartment .....	53
Recommended Fluid and Capacity ..	239
Replacement of Fuse .....	194
Replacement of Key Battery .....	177

---

Rescuing the Vehicle in Case of Fire .....	228
Roof Rail .....	55

Wiper Combination Switch .....	72
Wired Charging .....	91
Wireless Charging .....	92

## S

Safety Sign Information .....	214
Seat Memory Function of Driver Seat* .....	58
Selection of Child Restraint System ...	26
Steering Wheel Buttons .....	60
Sun Visor and Vanity Mirror .....	94

## T

Three-point Seat Belt .....	18
Towing .....	204
Towing Ring .....	205
Traction Control System (TCS) .....	112
Traffic Sign Identification (TSI) System .....	154
Tyre .....	187
Tyre Pressure Monitoring System (TPMS) .....	115

## U

Unlocking Door during Emergency ..	203
Using The Child Restraint System .....	28

## V

Vehicle Identification Number .....	235
Vehicle Locking and Unlocking .....	41
Vehicle Sound for Pedestrian .....	114
Vehicle Storage .....	233
VIN Label .....	236

## W

Waking up the System .....	185
Warnings and Indicators .....	85
Washer Fluid .....	182
Weight .....	237
Wheel Alignment Specification .....	238
Wiper Blades .....	182



Download on the  
**App Store**



GET IT ON  
**Google Play**



EXPLORE IT ON  
**AppGallery**

**Proton New Energy Technology Sdn Bhd** 202201030092 (1475789-X)  
Proton Centre of Excellence,  
KM33.8 Westbound Shah Alam Expressway,  
47600 Subang Jaya, Selangor Darul Ehsan, Malaysia.

Language : ENGLISH  
Market : MHR  
Model : e.MAS 7  
Published : DEC 2025  
Published in : MALAYSIA

[emas.proton.com](https://emas.proton.com)

**PROTON e.MAS Customer Care 1 300 88 8877**

A Member of

**DRB-HICOM**